

Axon guidance

all genes

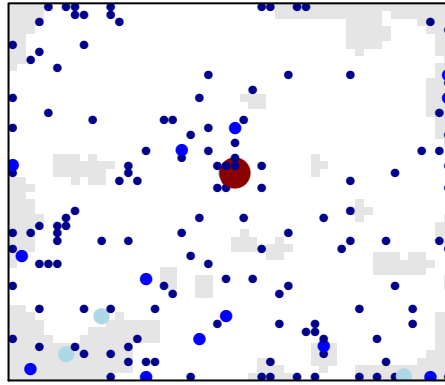

maximum = 7

sink node genes

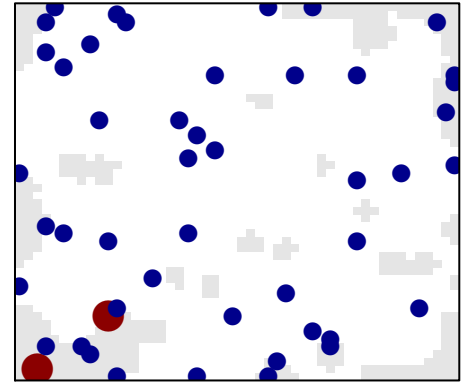

maximum = 2

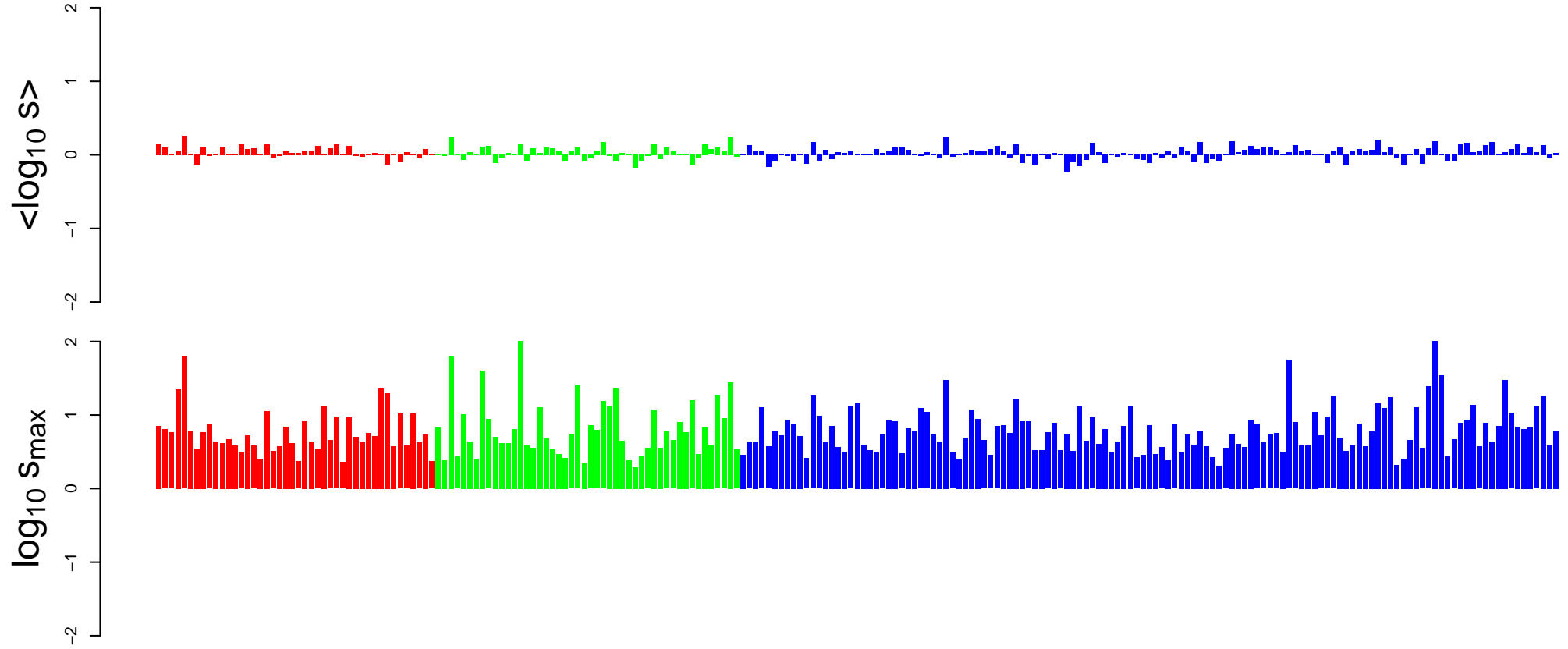

Axon guidance
(genes with data)

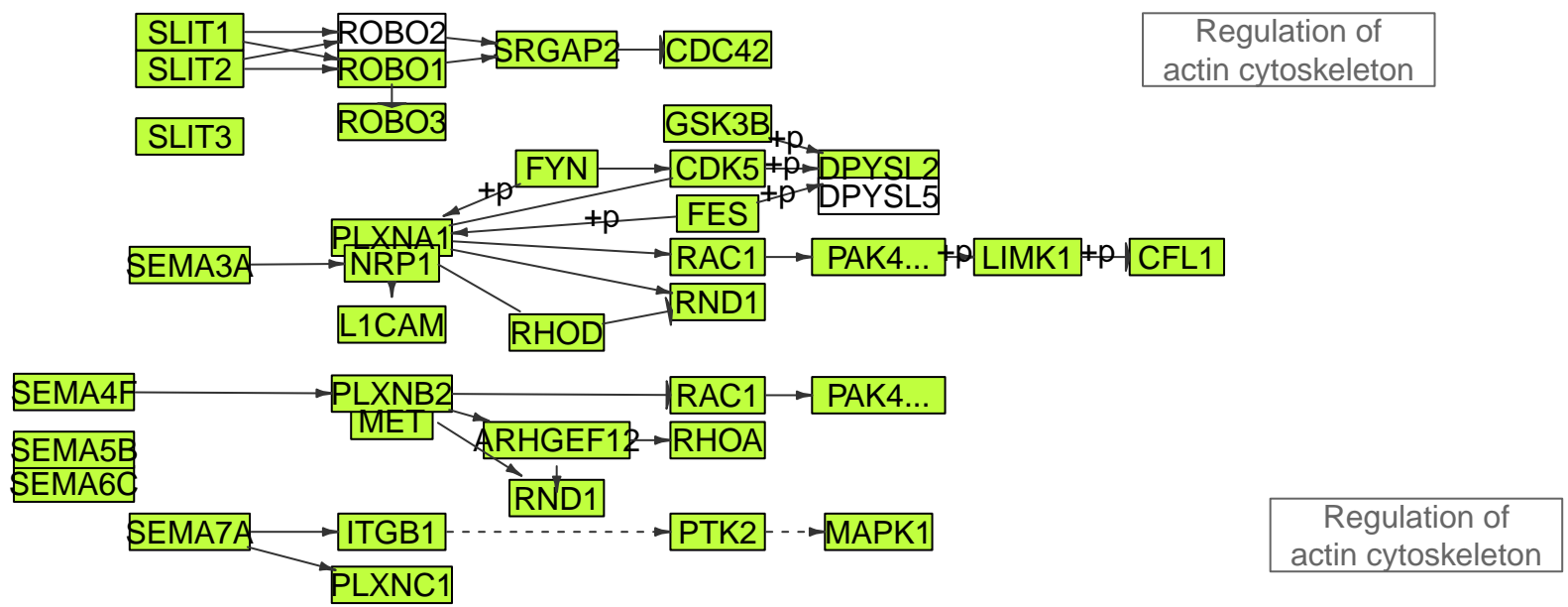
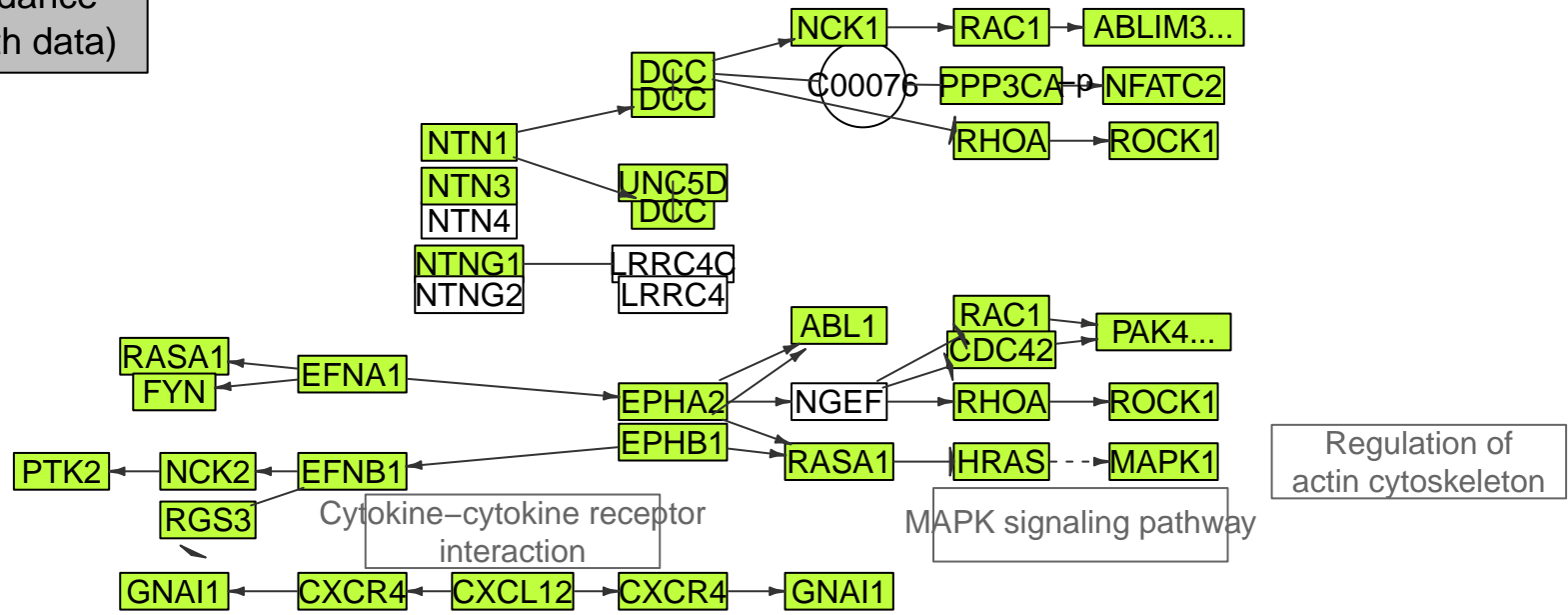

Axon guidance (sink nodes)

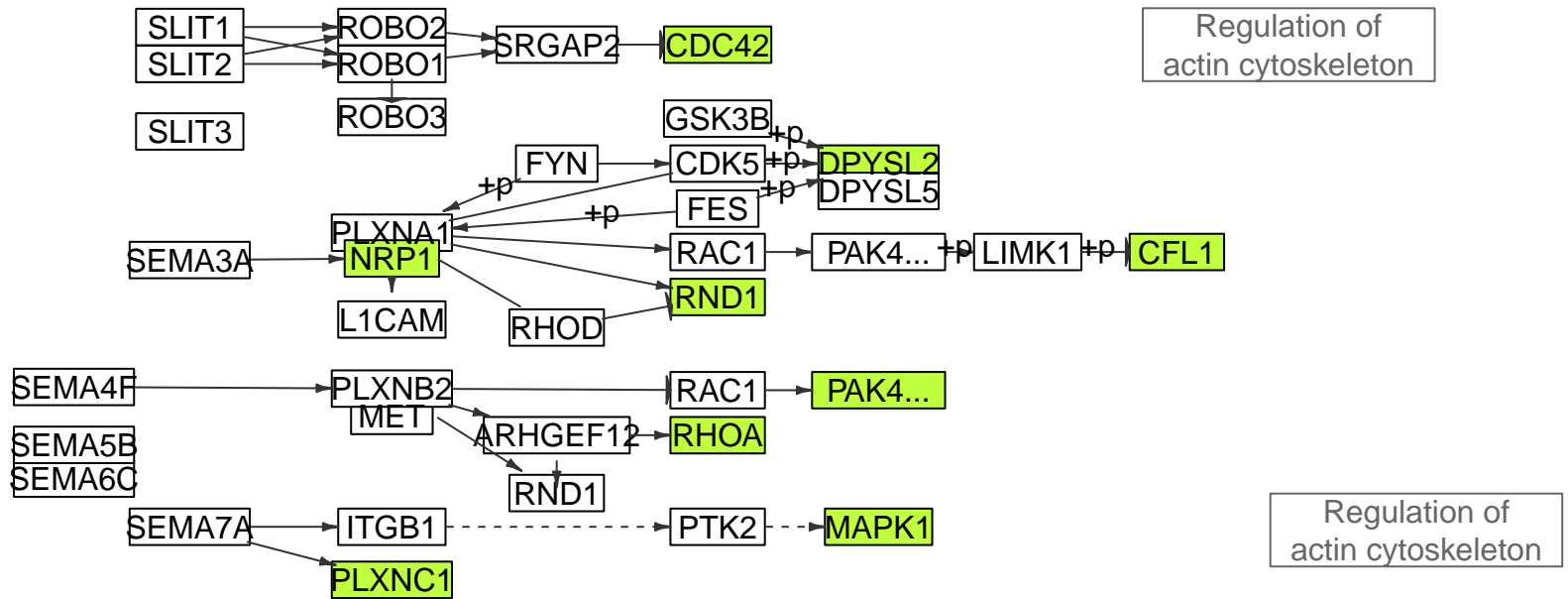
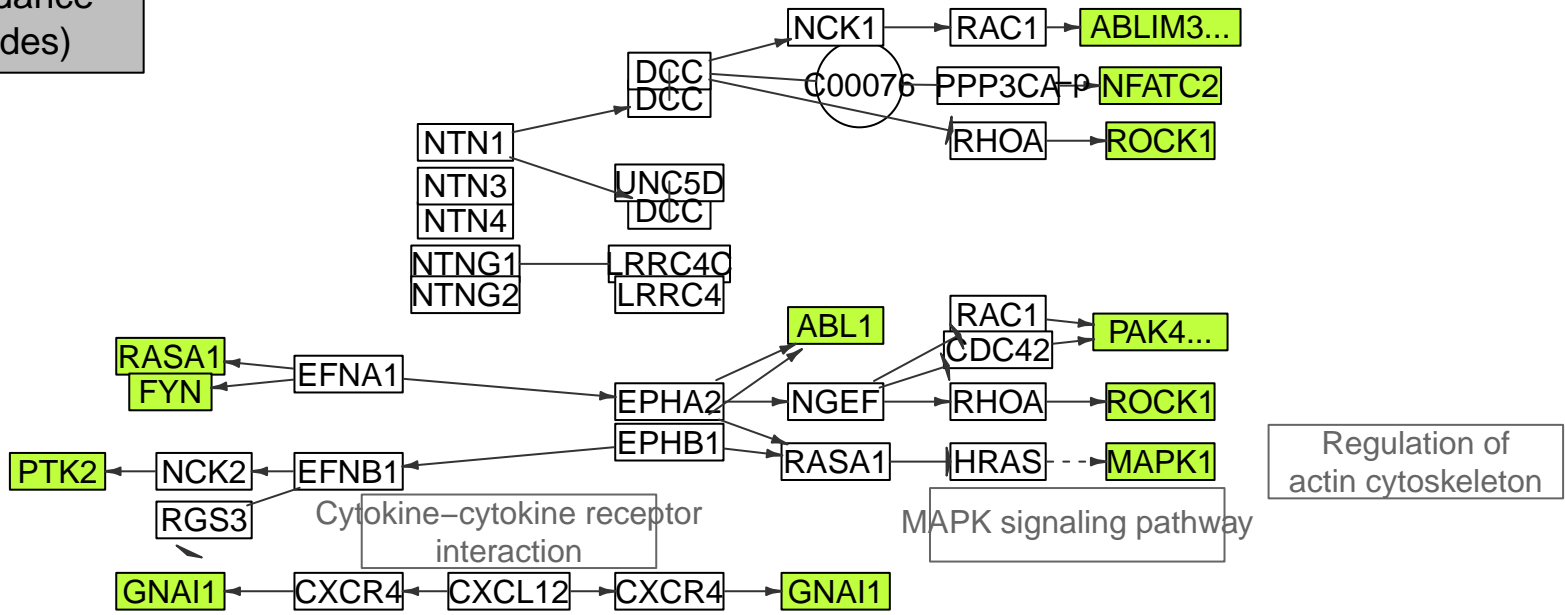

Axon guidance
MPI-001

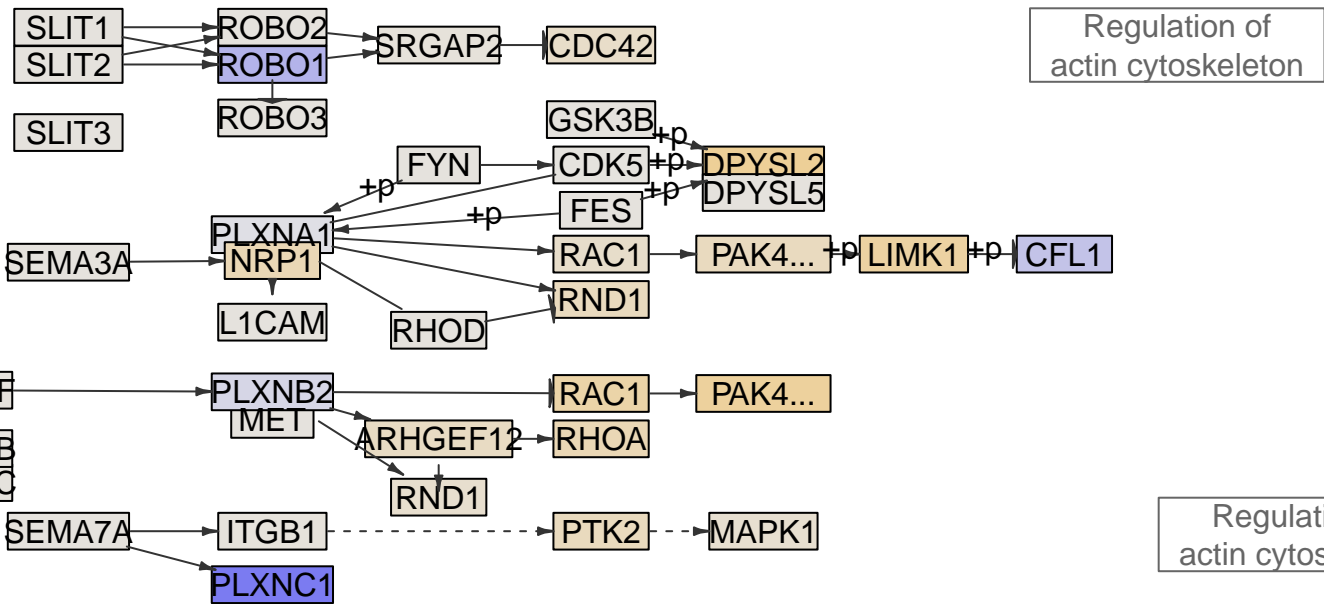
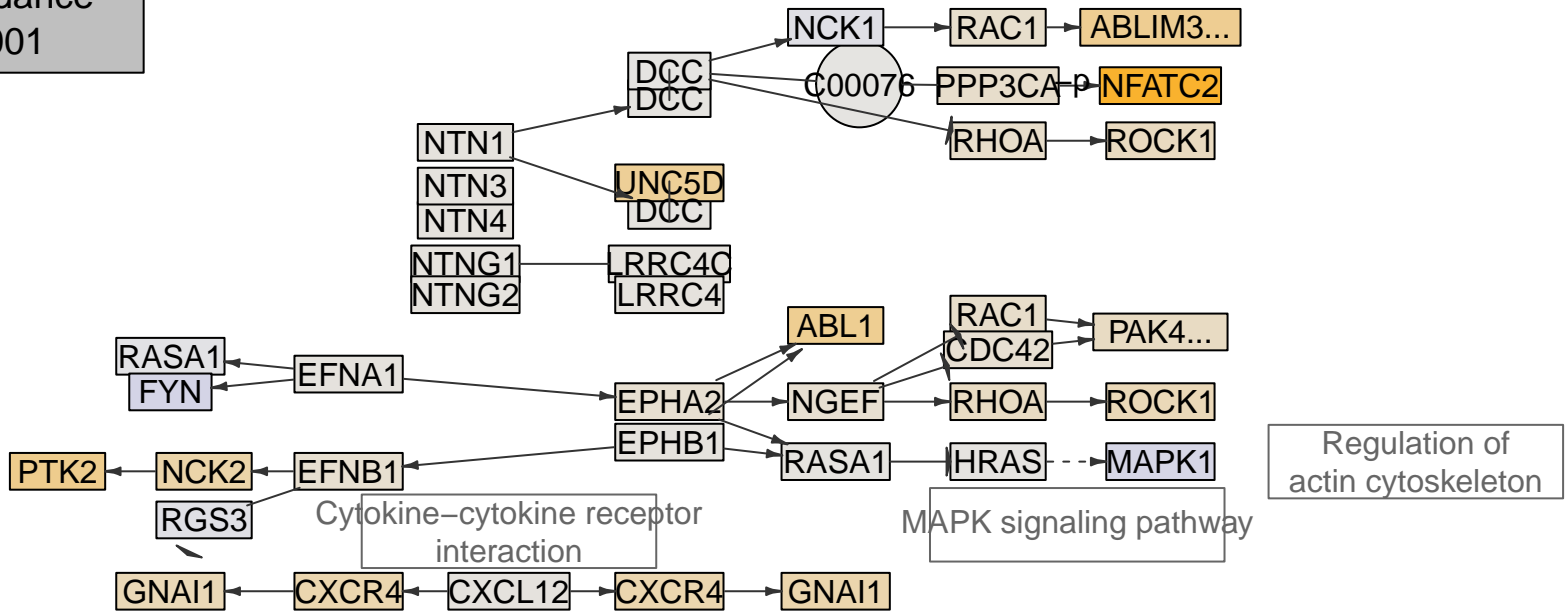

Axon guidance
MPI-002

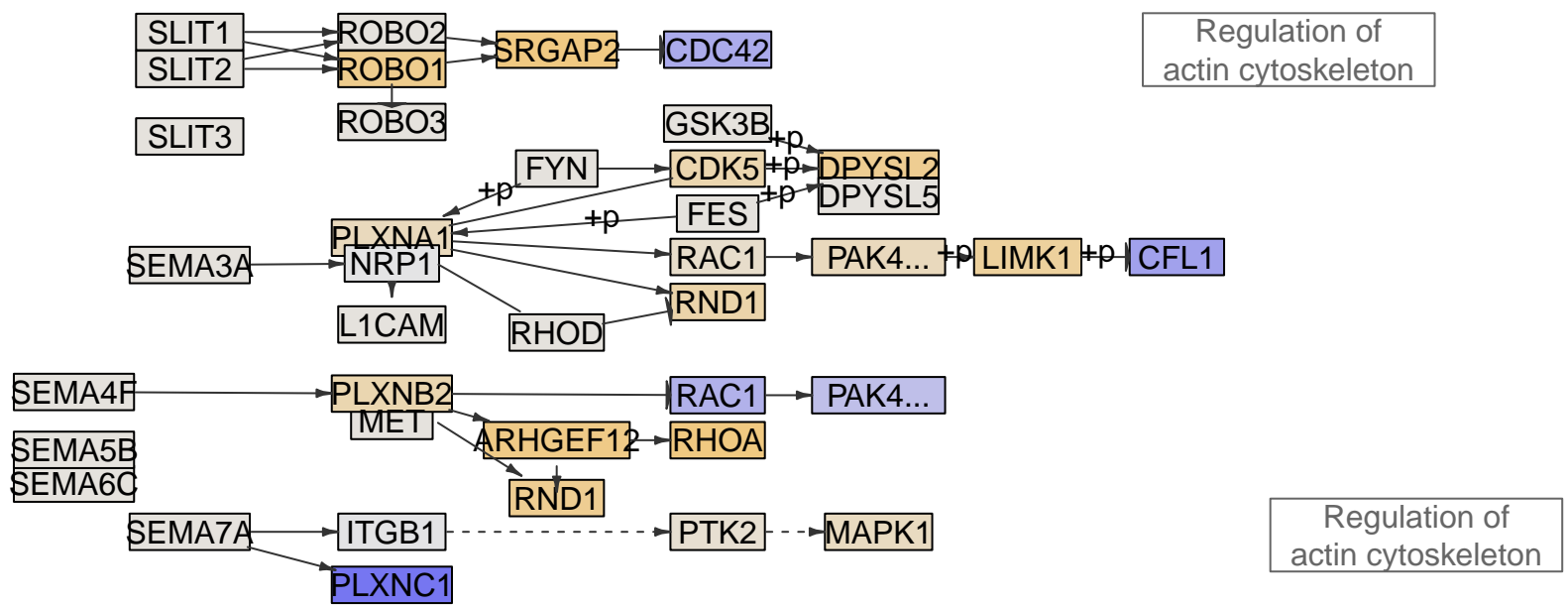
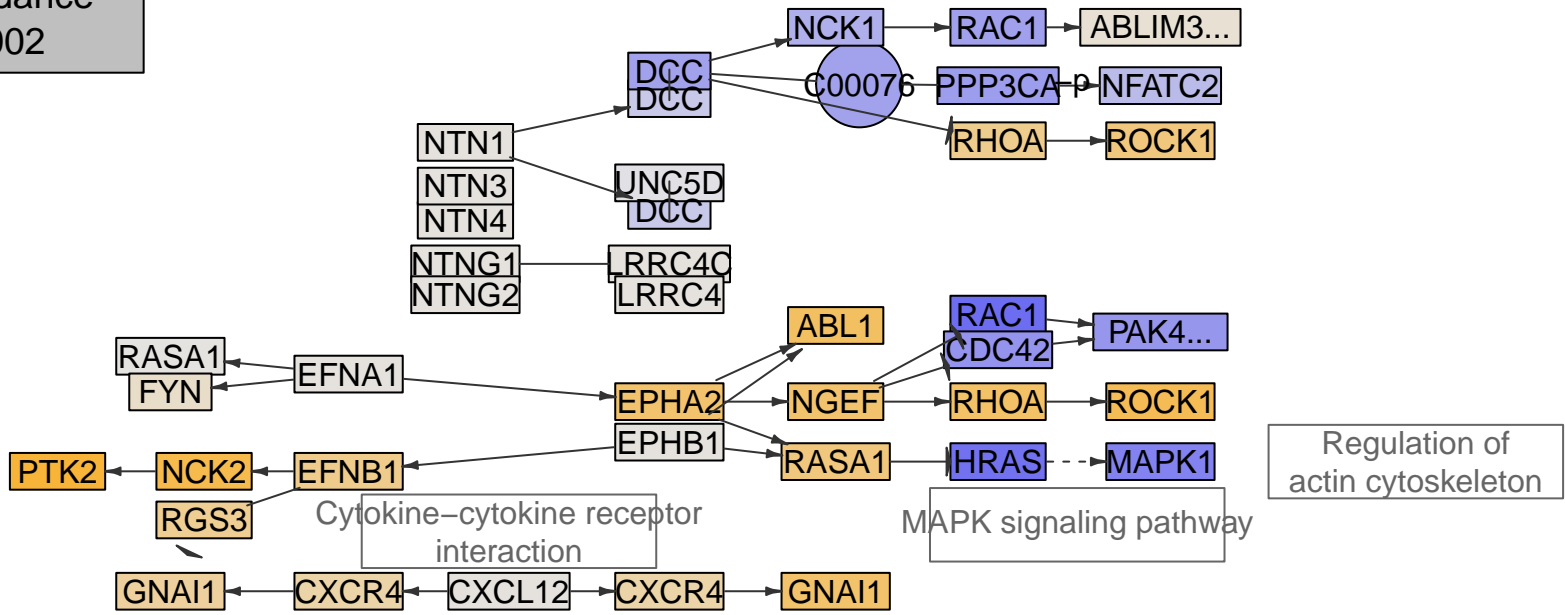

Axon guidance
MPI-003

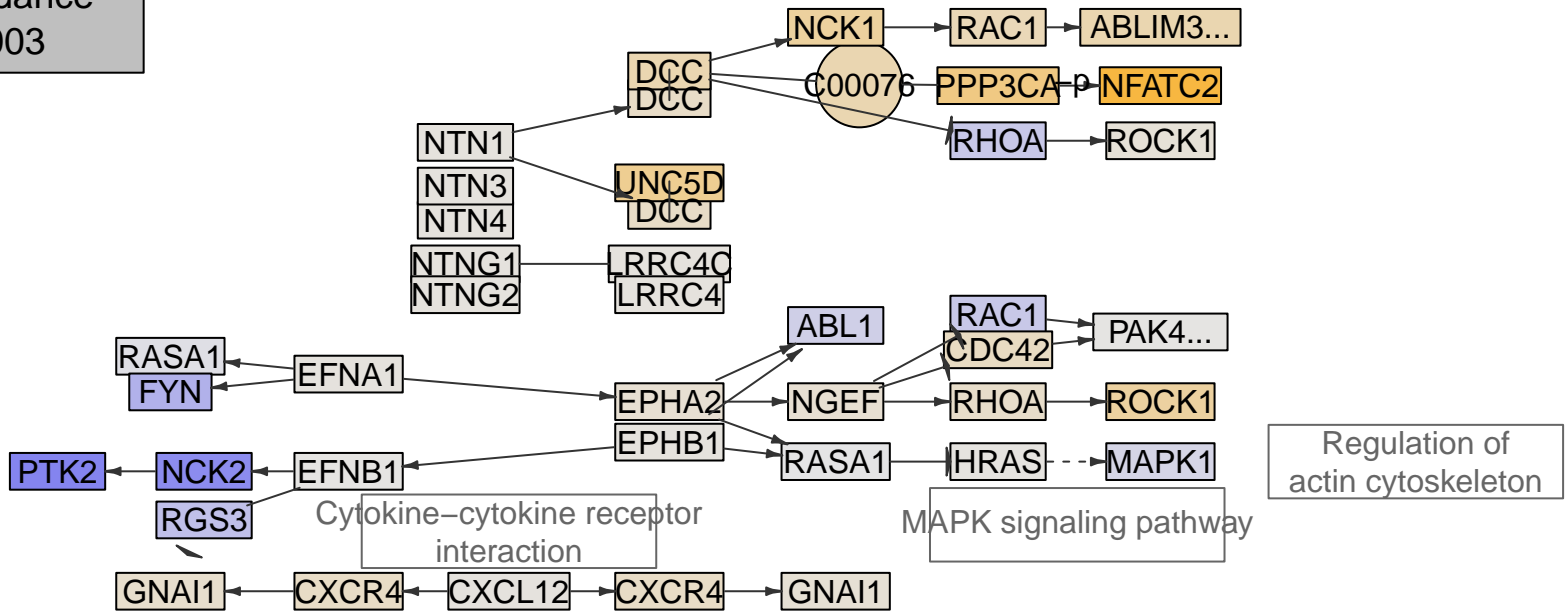

Regulation of actin cytoskeleton

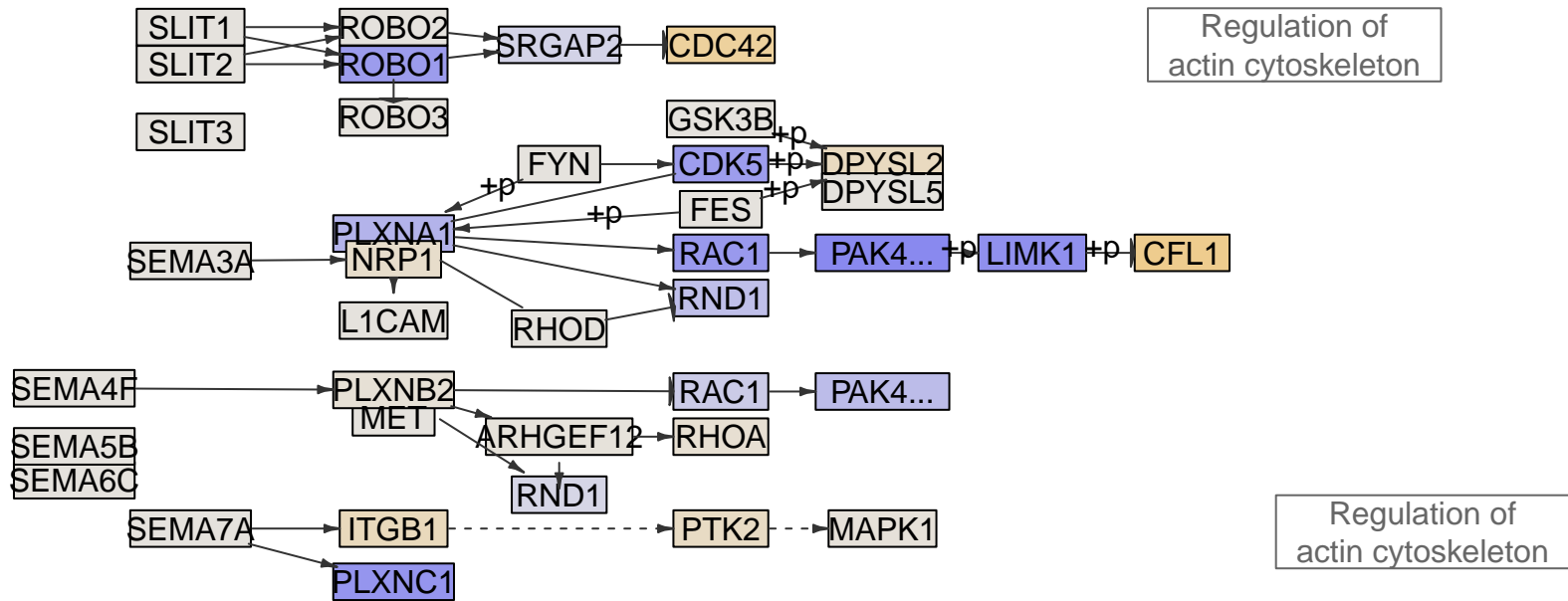

Regulation of actin cytoskeleton

Regulation of actin cytoskeleton

Axon guidance
MPI-005

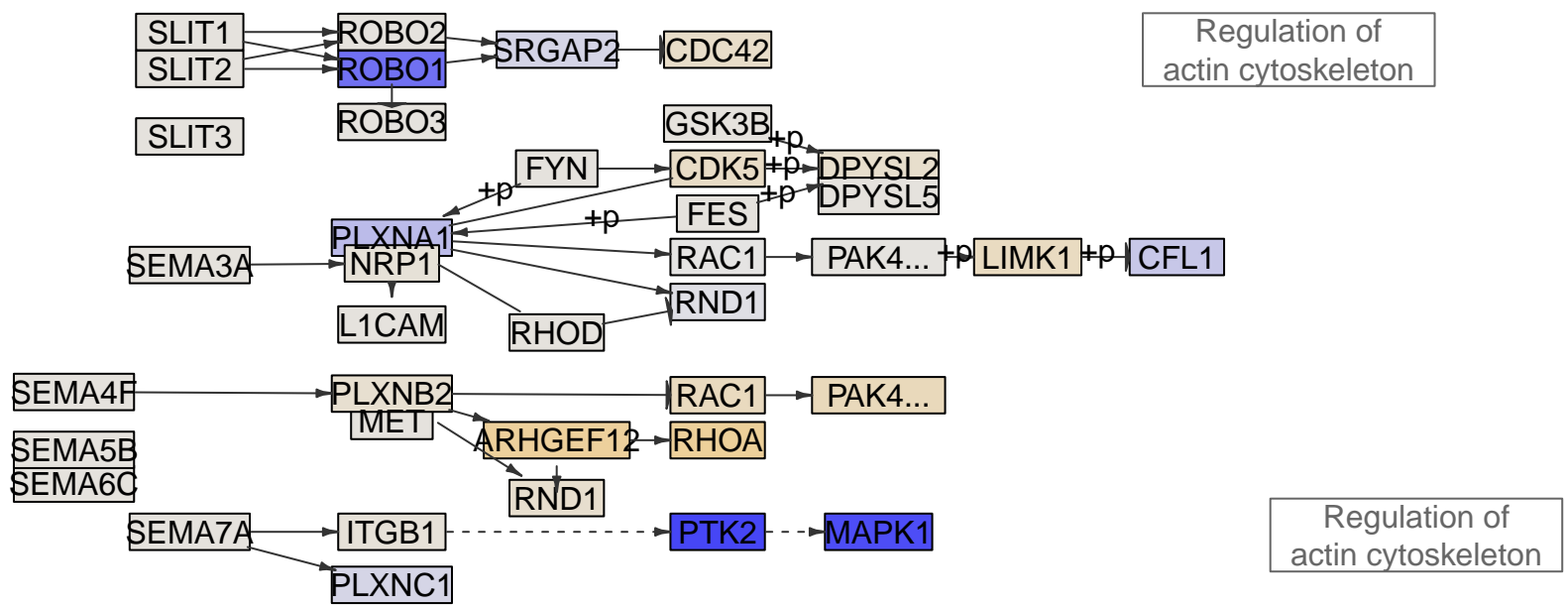
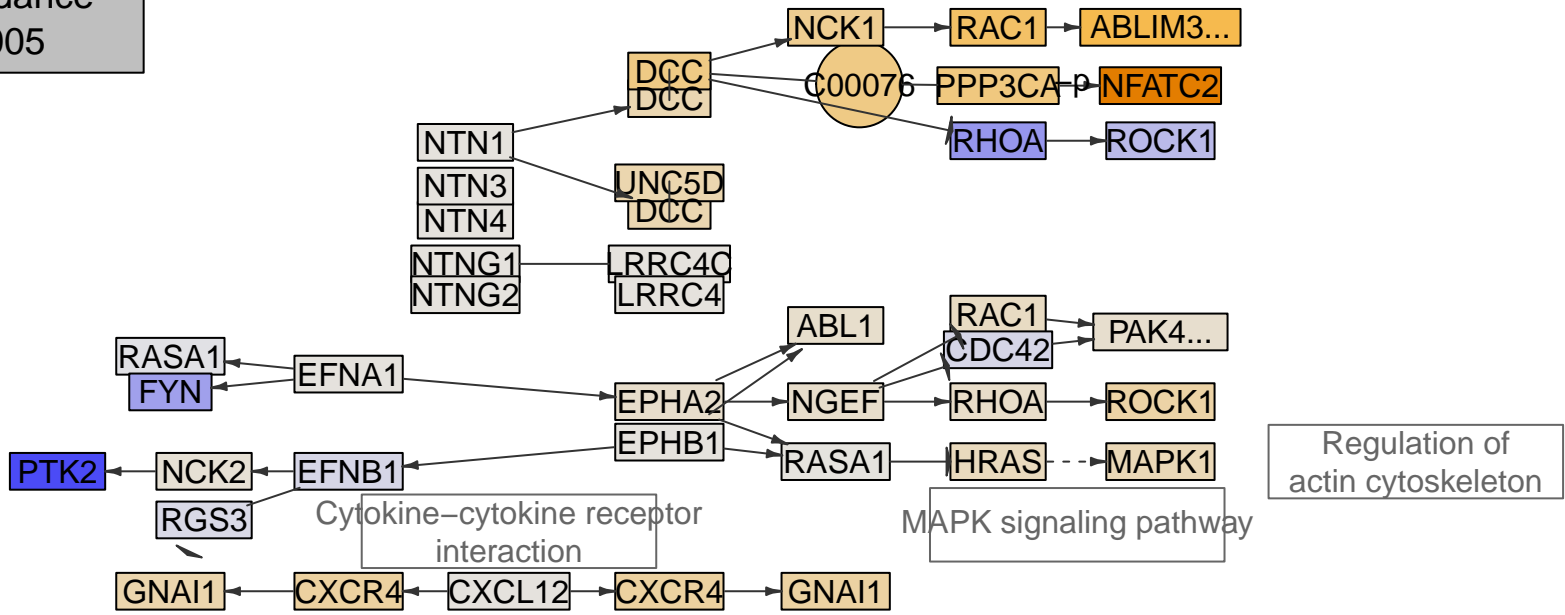

Axon guidance
MPI-006

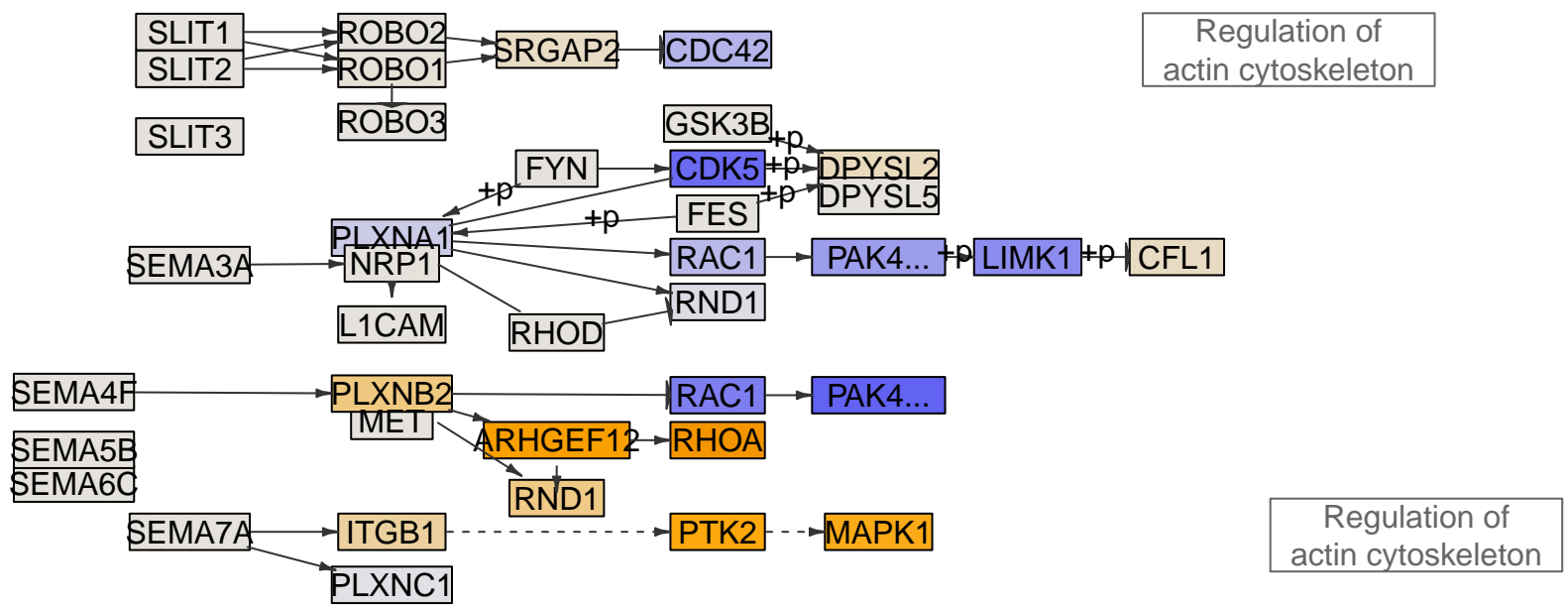
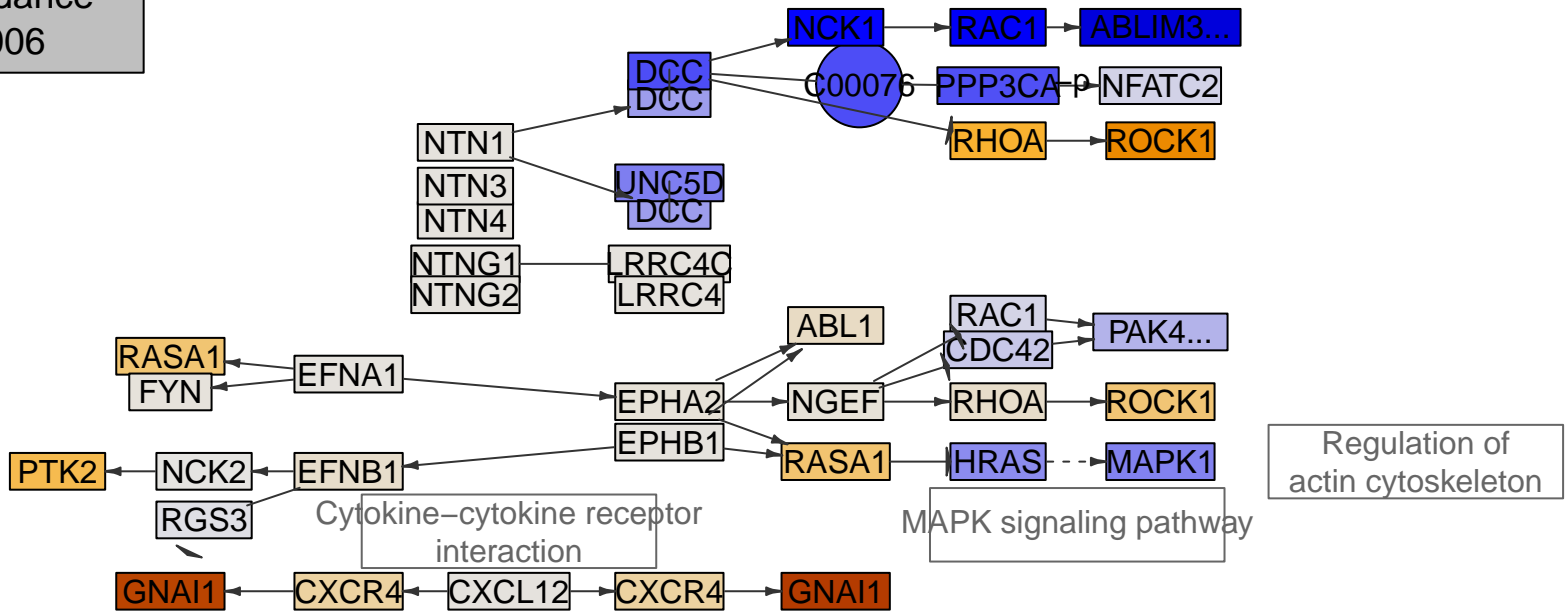

Axon guidance
MPI-016

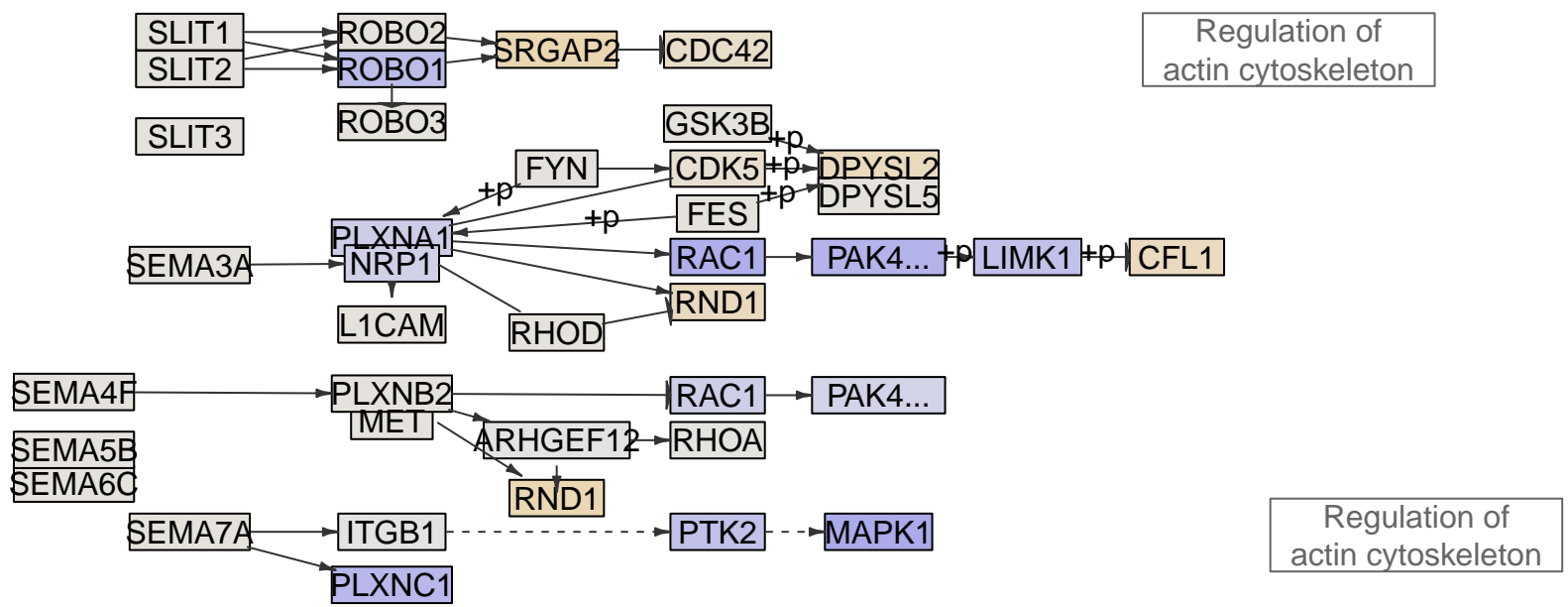
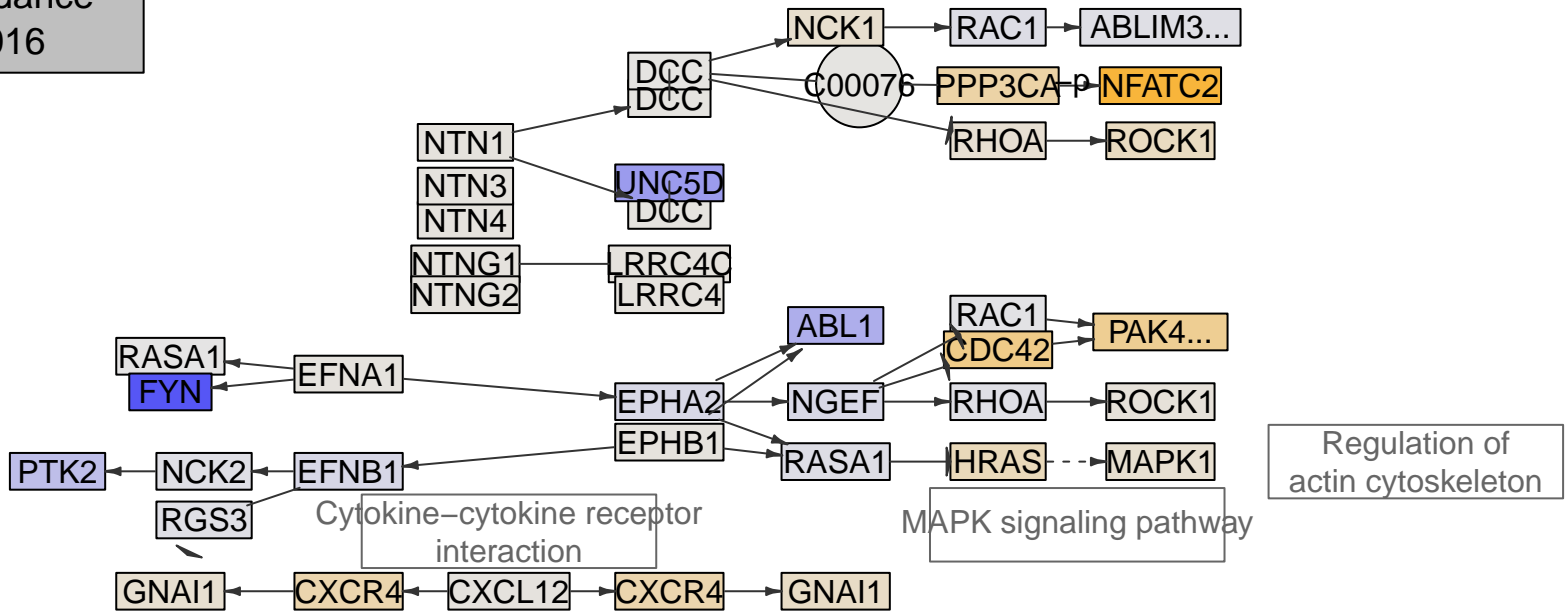

Axon guidance
MPI-017

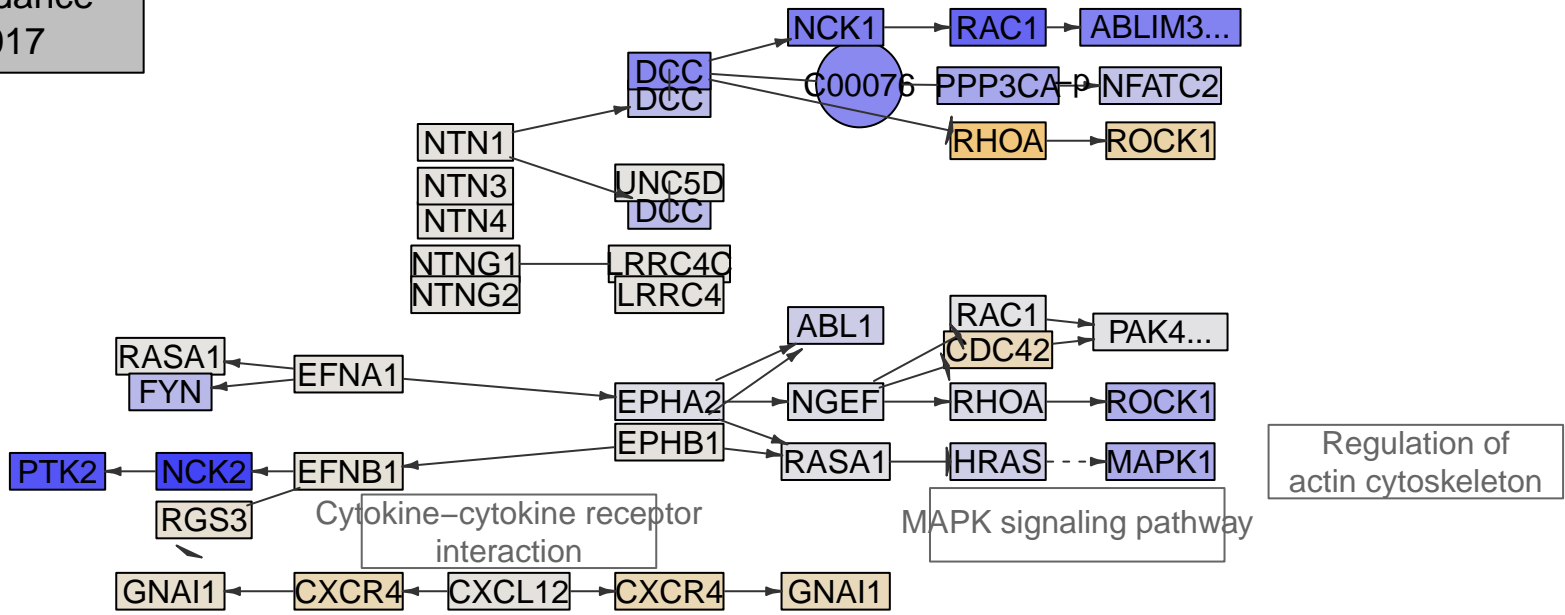

Regulation of actin cytoskeleton

MAPK signaling pathway

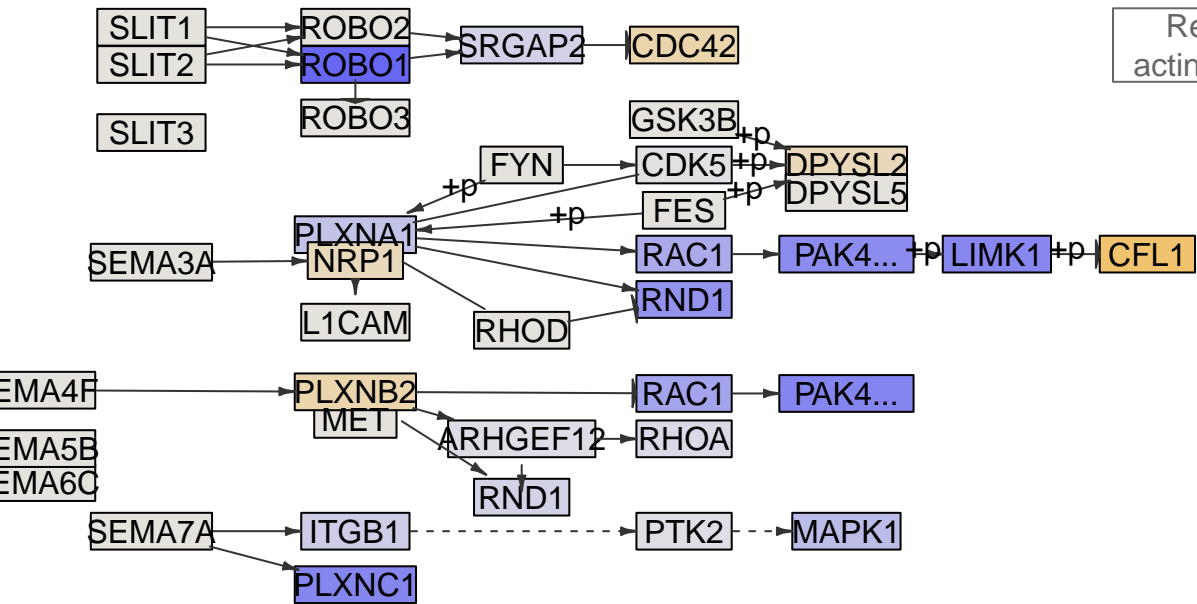

Regulation of actin cytoskeleton

Regulation of actin cytoskeleton

Axon guidance
MPI-018

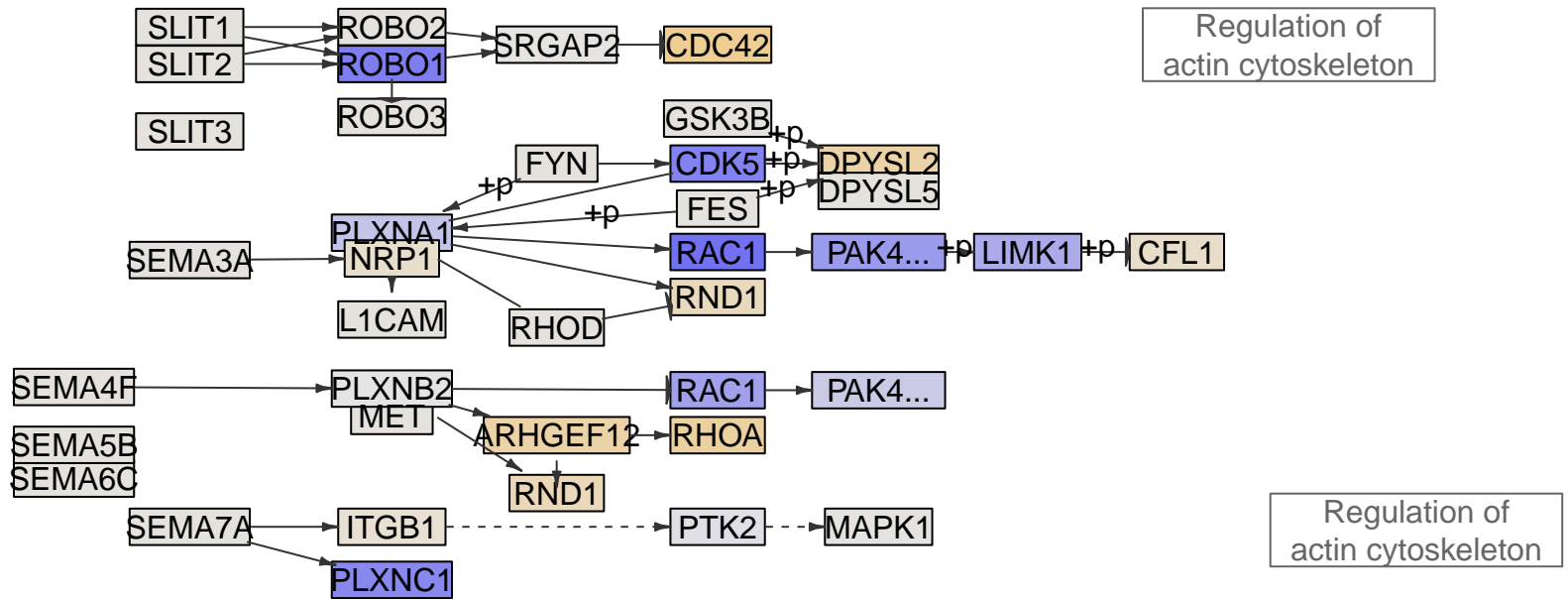
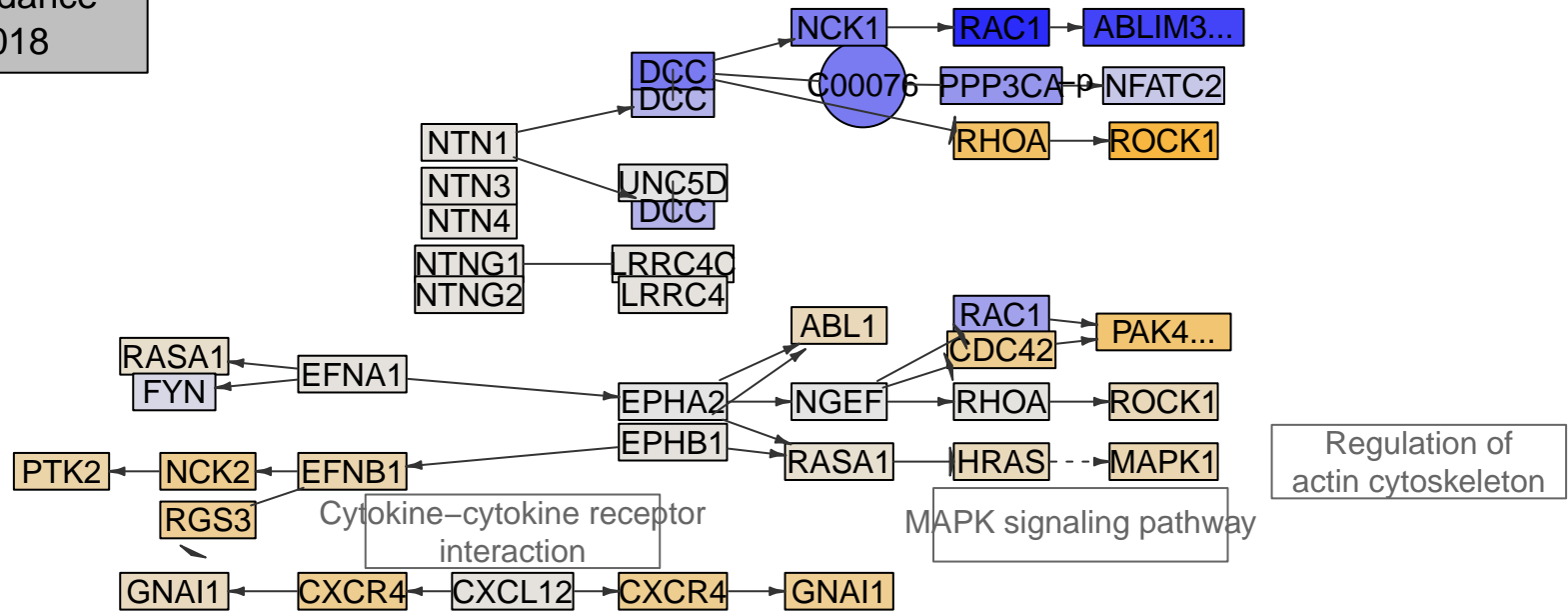

Axon guidance
MPI-027

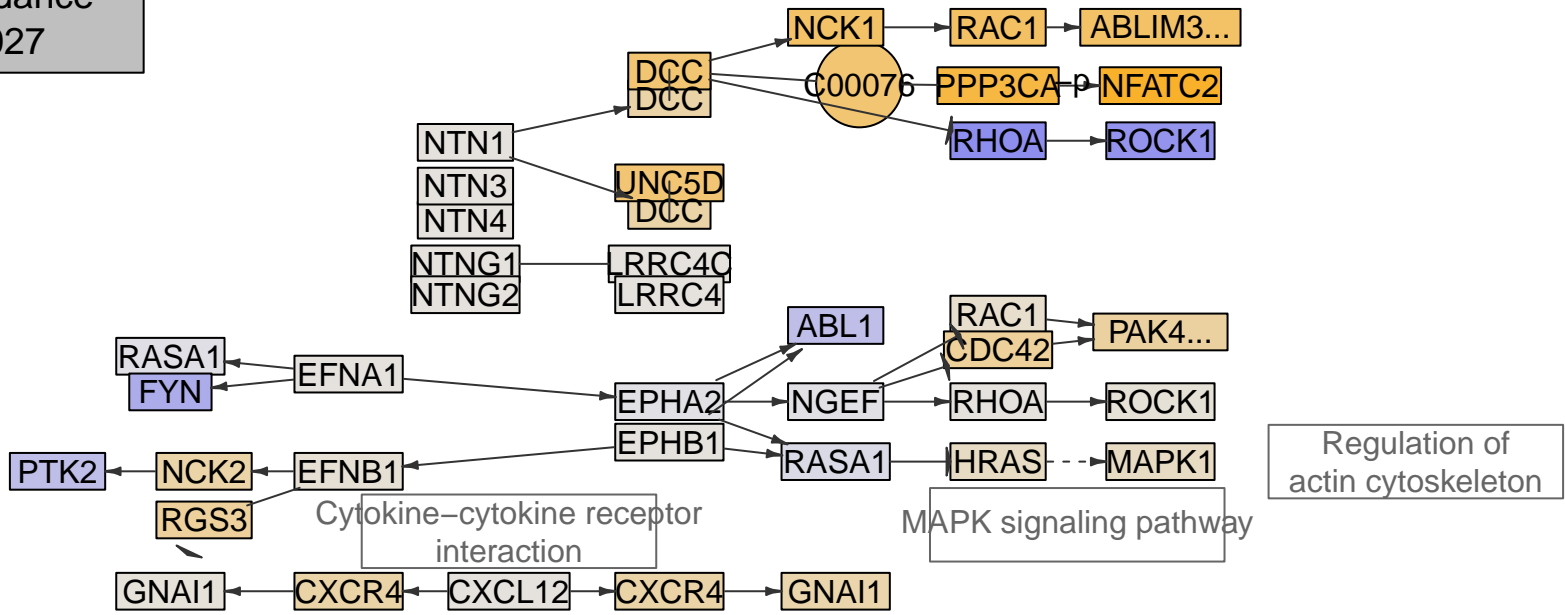

Regulation of actin cytoskeleton

MAPK signaling pathway

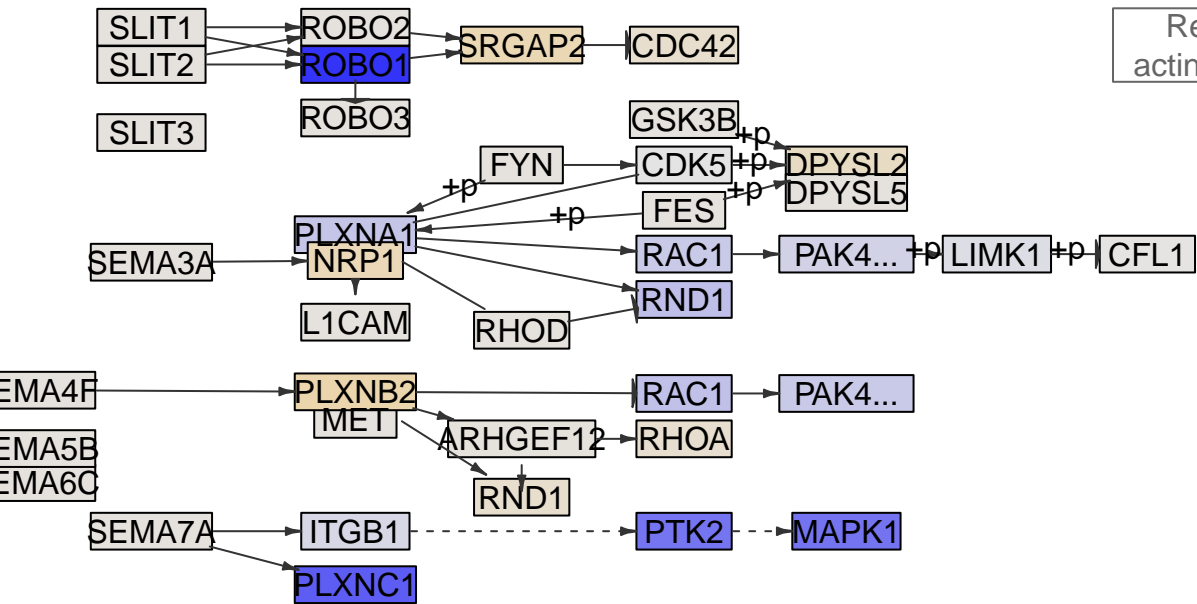

Regulation of actin cytoskeleton

Regulation of actin cytoskeleton

Axon guidance
MPI-028

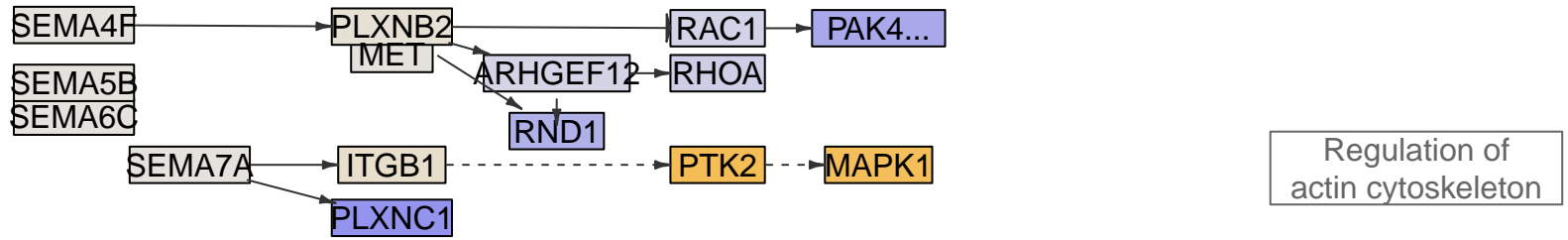
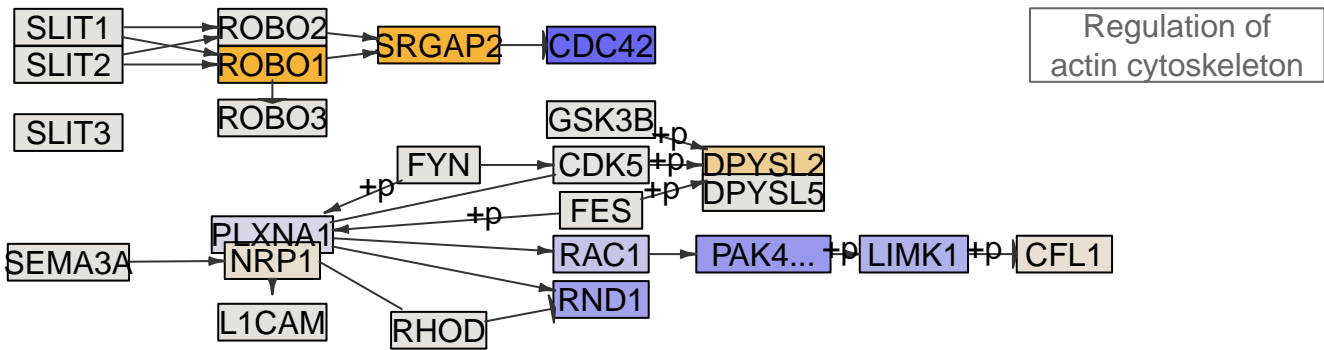
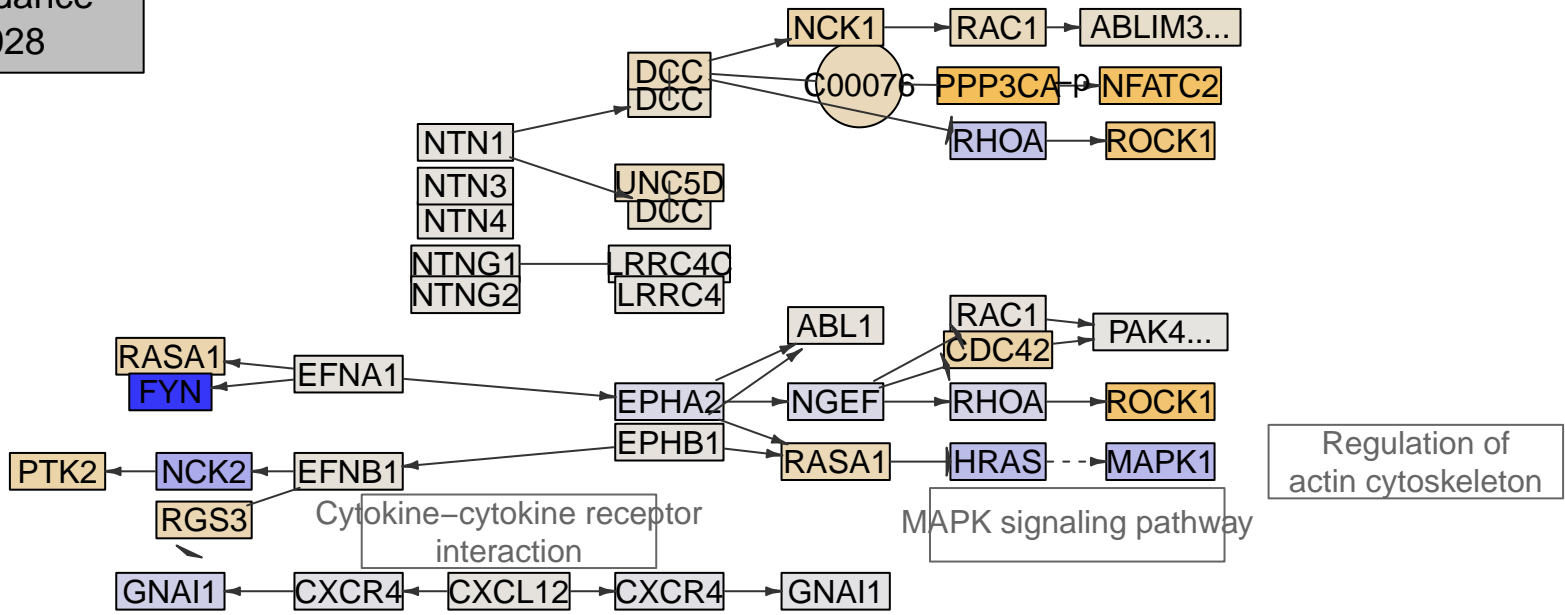

Axon guidance
MPI-032

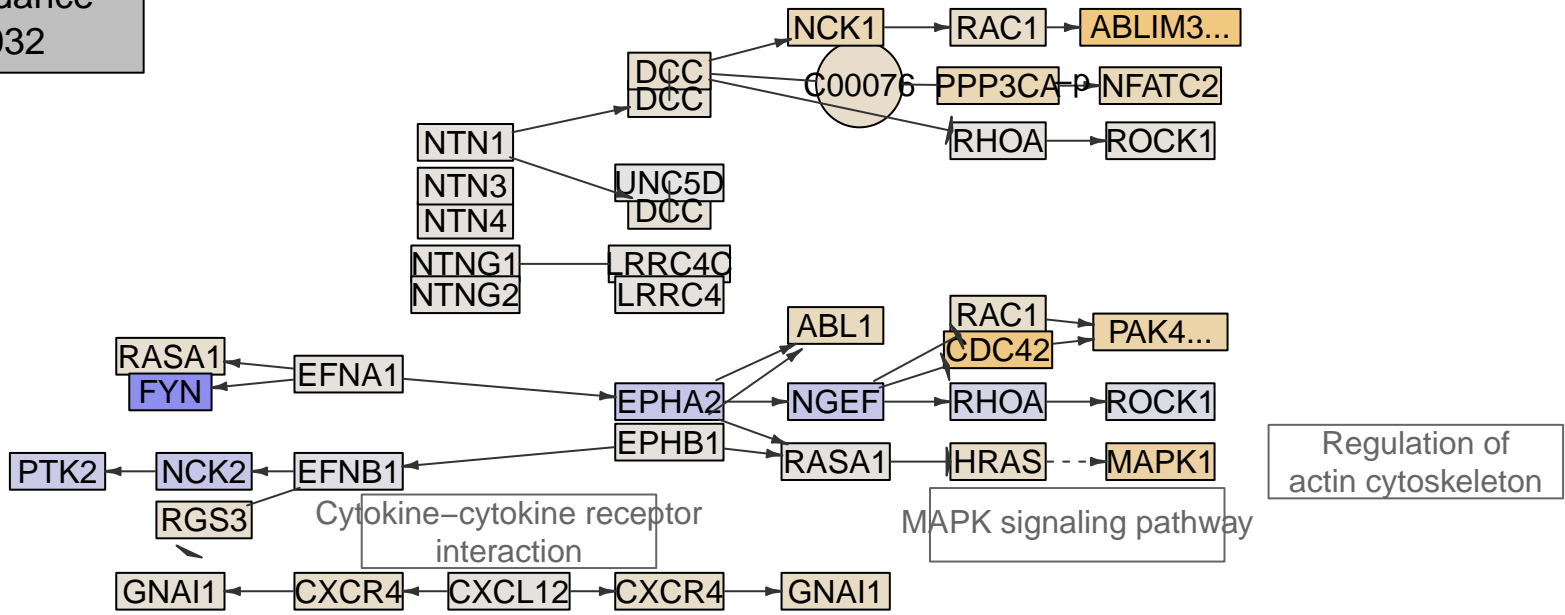

Regulation of actin cytoskeleton

MAPK signaling pathway

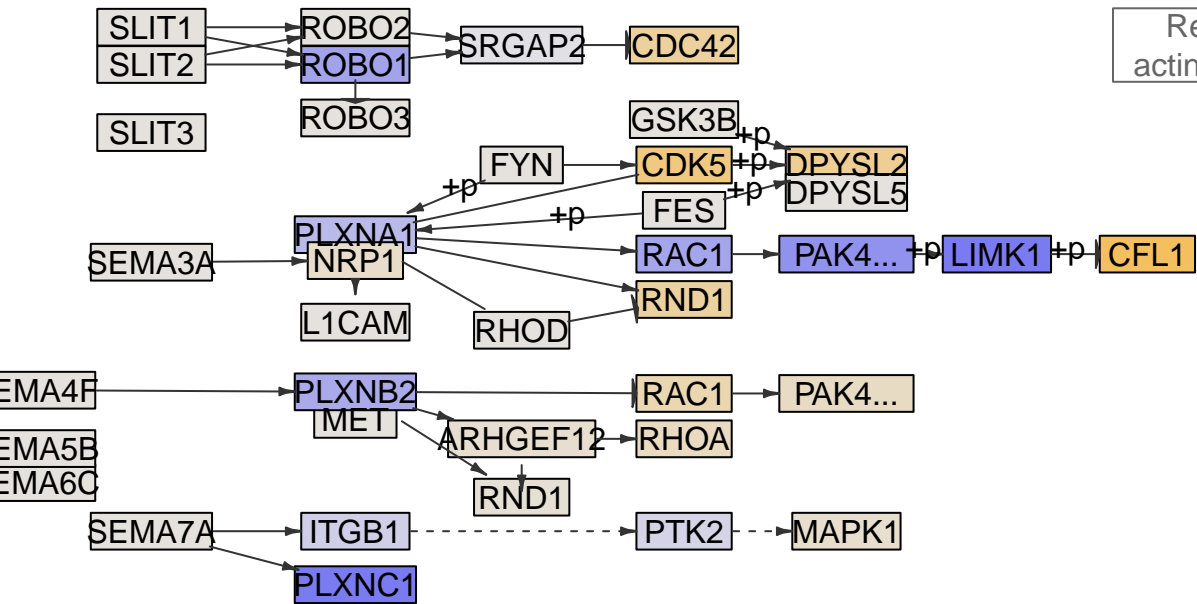

Regulation of actin cytoskeleton

Regulation of actin cytoskeleton

Axon guidance
MPI-033

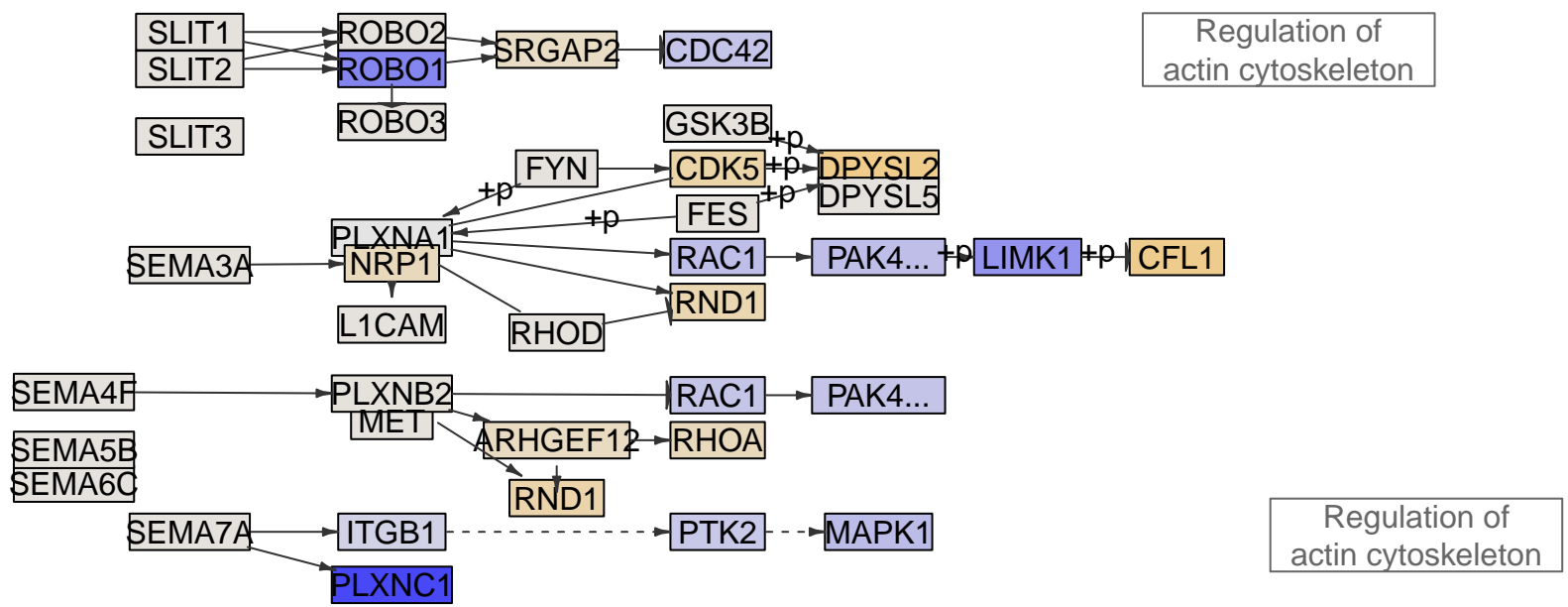
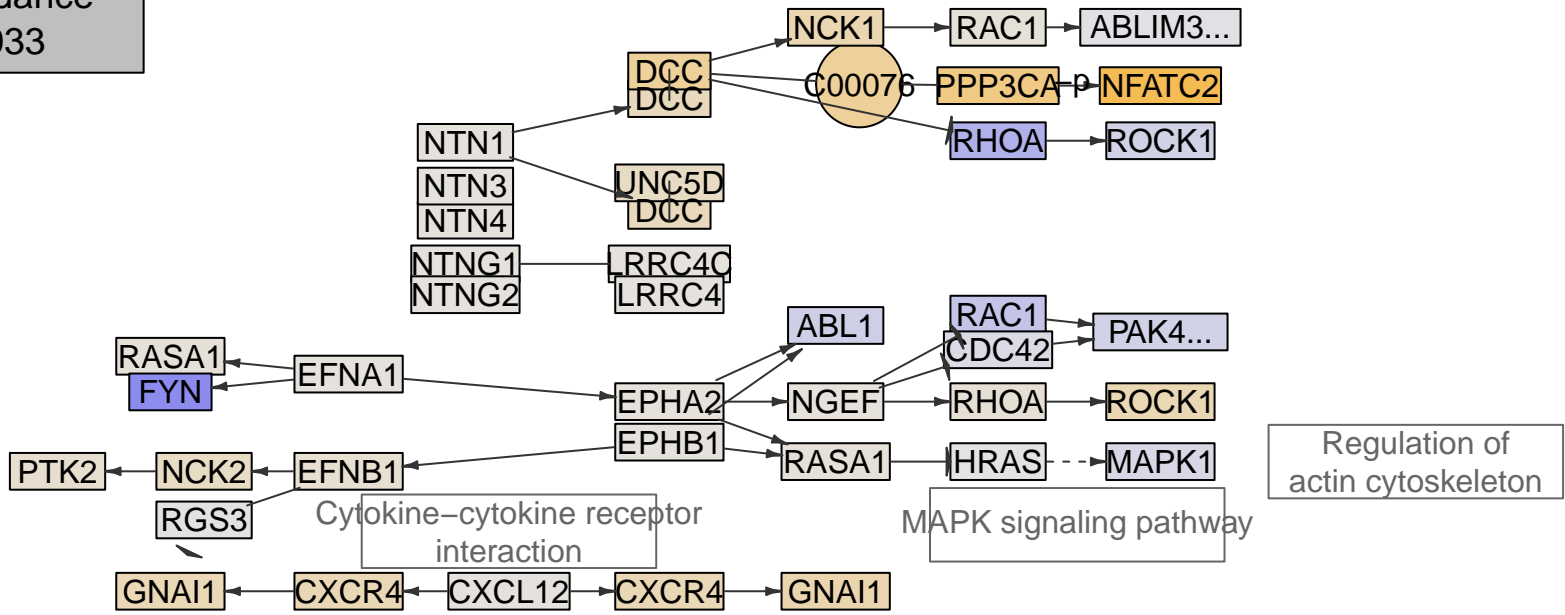

Axon guidance
MPI-034

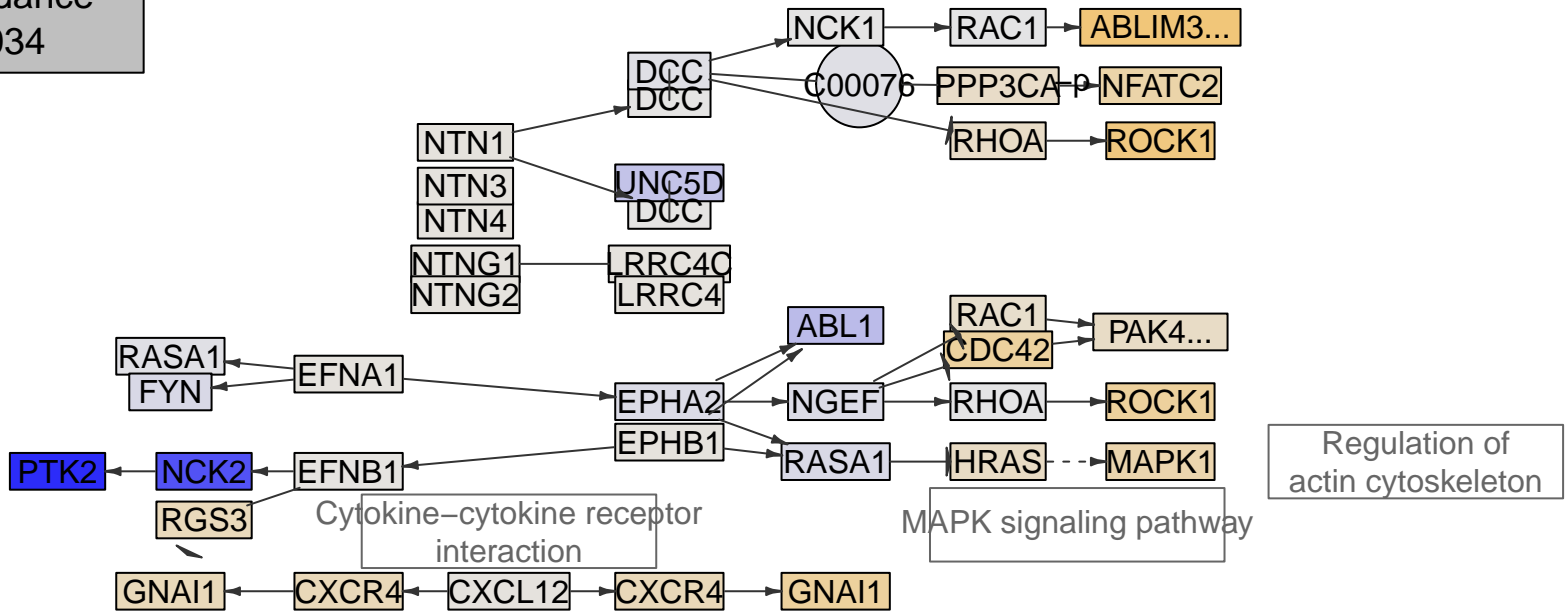

Regulation of actin cytoskeleton

MAPK signaling pathway

Cytokine-cytokine receptor interaction

Regulation of actin cytoskeleton

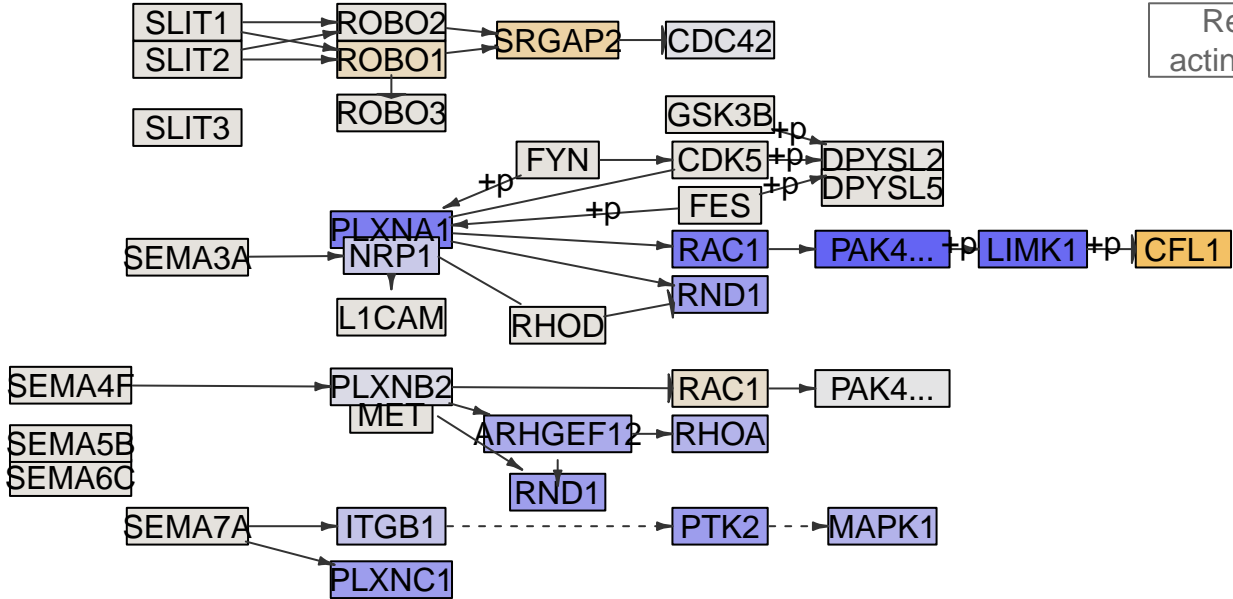

Regulation of actin cytoskeleton

Axon guidance
MPI-043

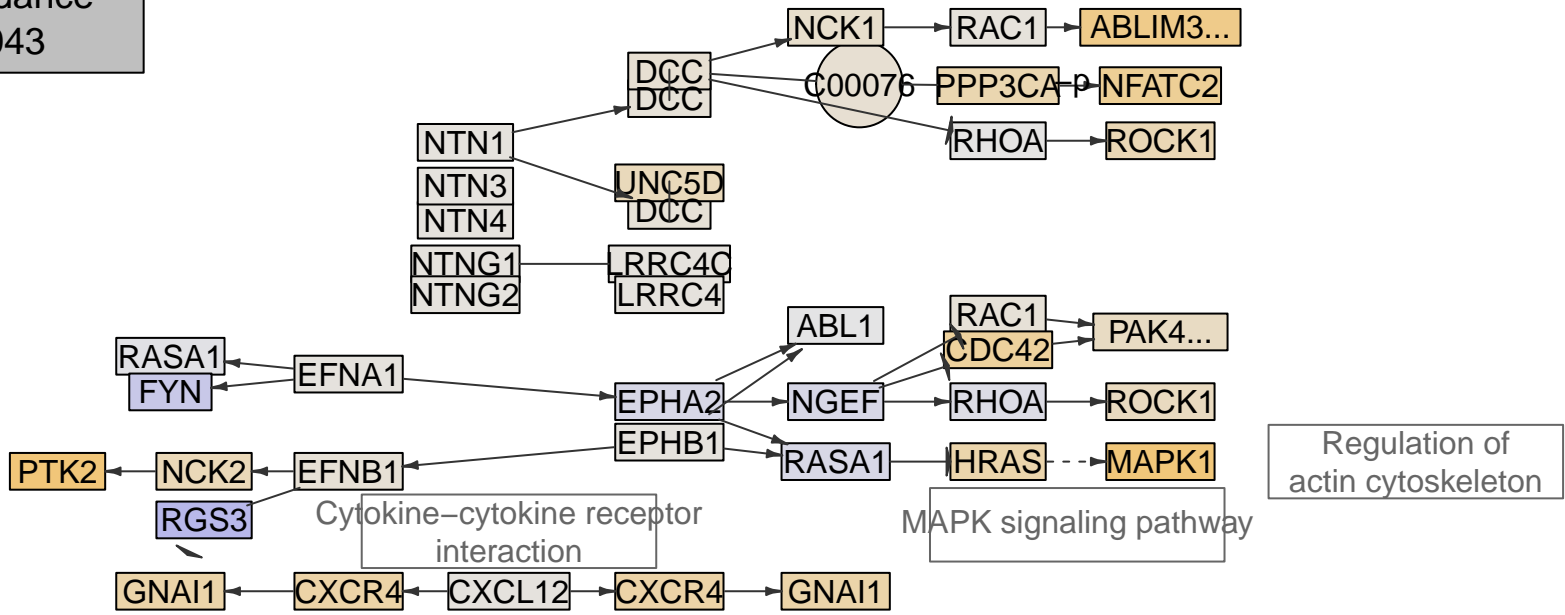

Regulation of actin cytoskeleton

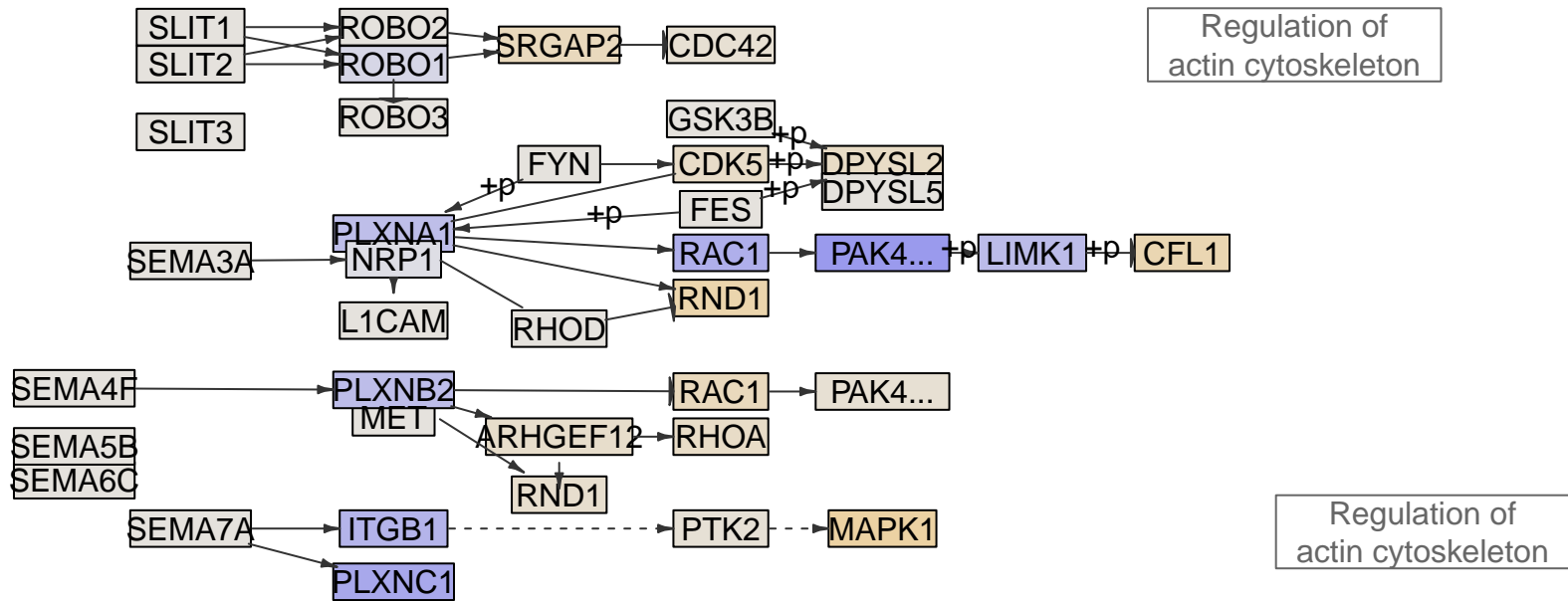

Regulation of actin cytoskeleton

Regulation of actin cytoskeleton

Axon guidance
MPI-044

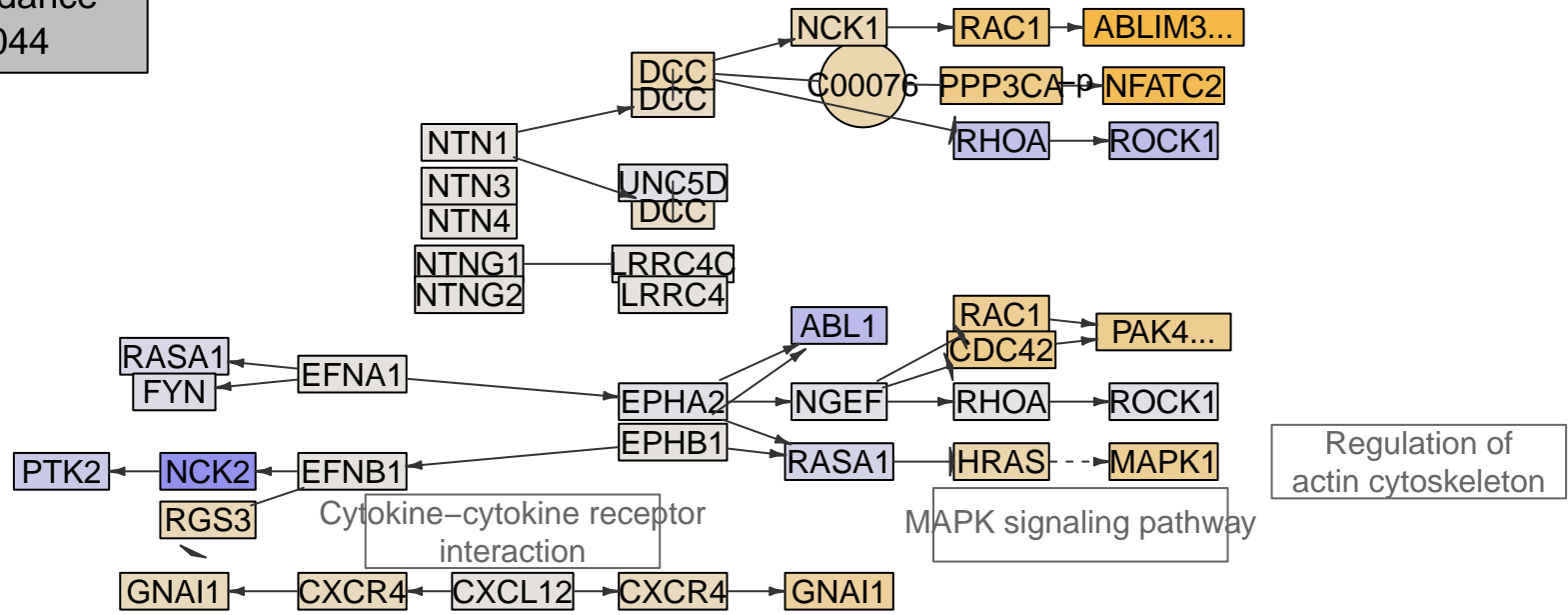

Regulation of actin cytoskeleton

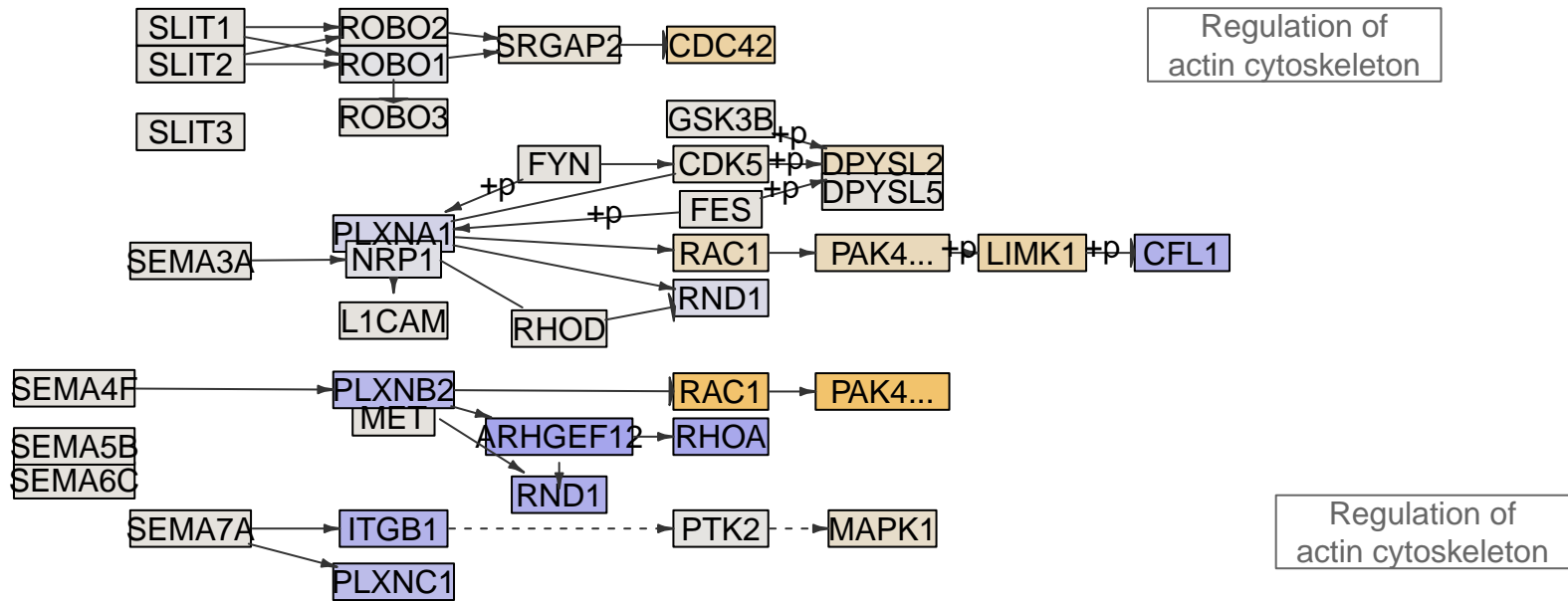

Regulation of actin cytoskeleton

Regulation of actin cytoskeleton

Axon guidance
MPI-048

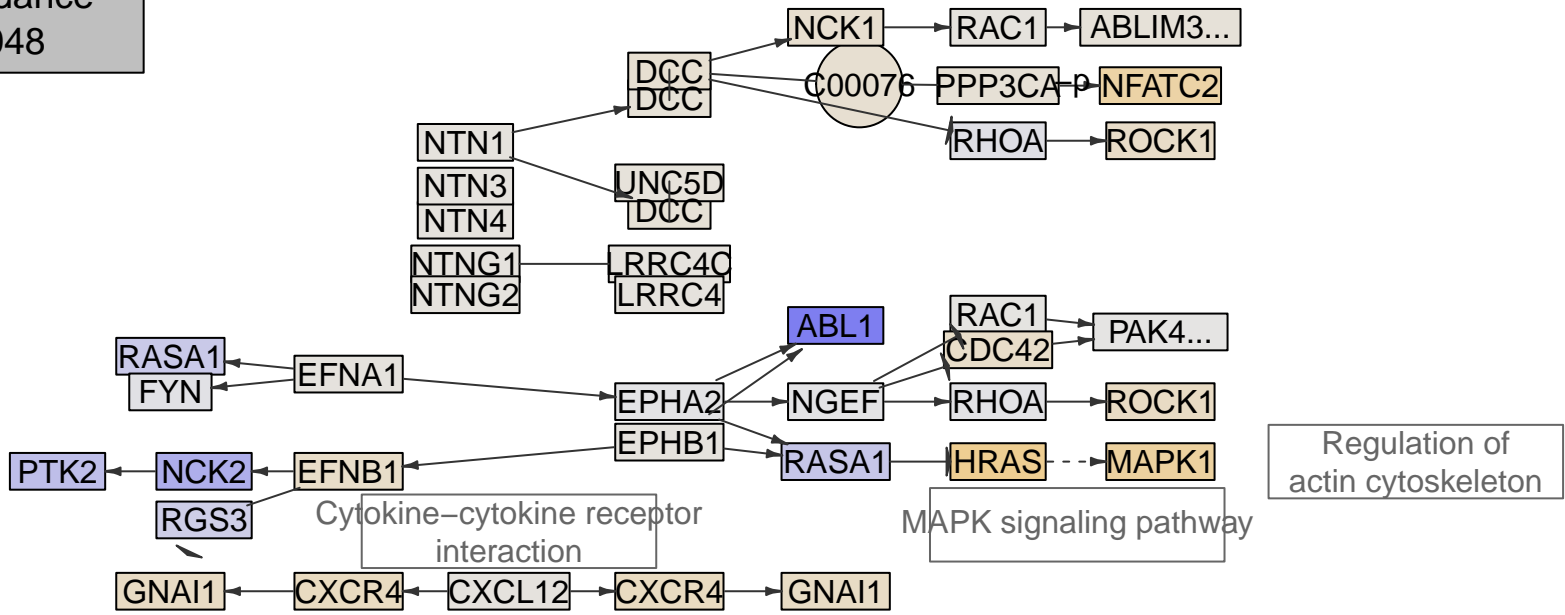

Regulation of actin cytoskeleton

MAPK signaling pathway

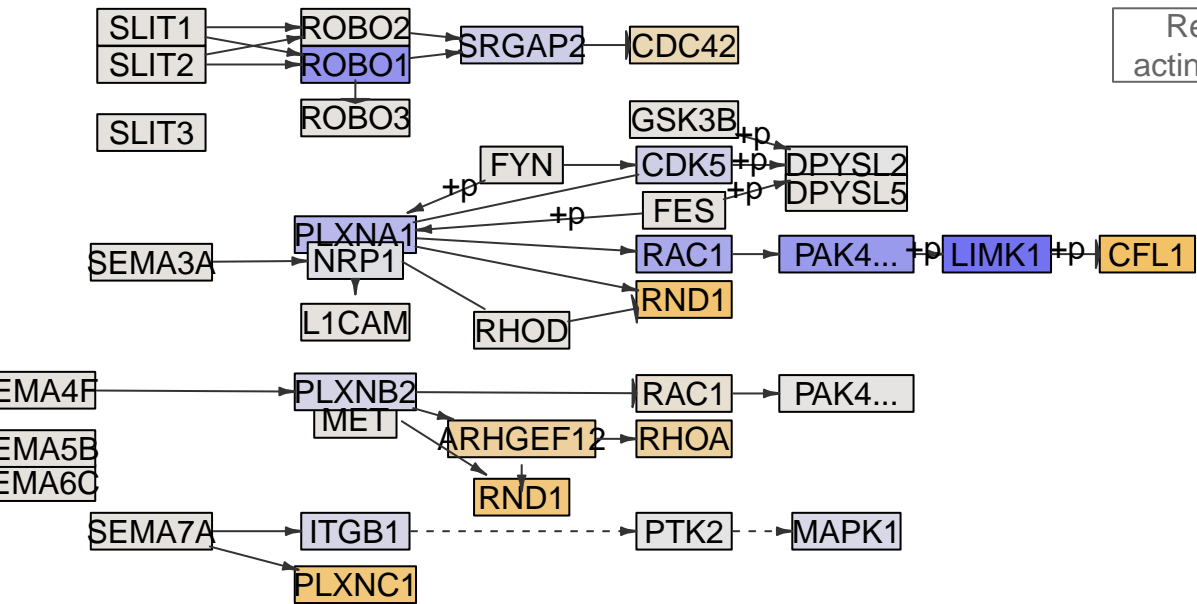

Regulation of actin cytoskeleton

Regulation of actin cytoskeleton

Axon guidance
MPI-055

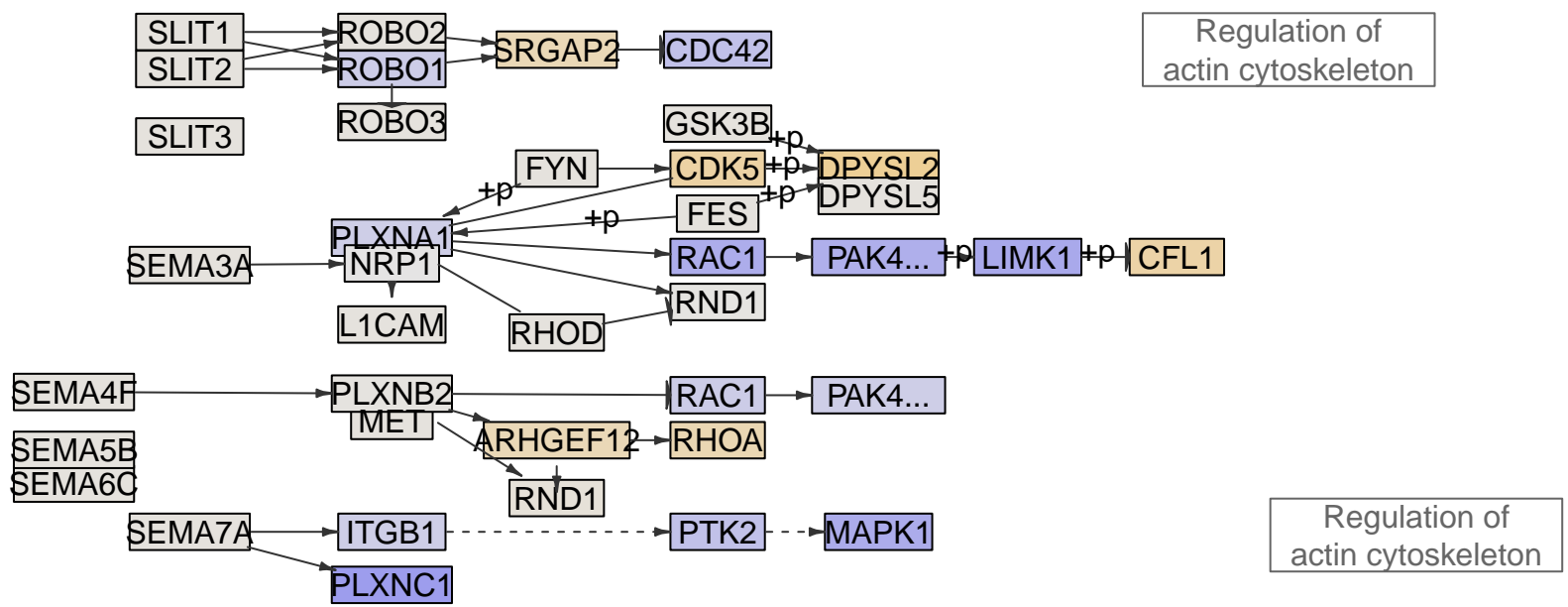
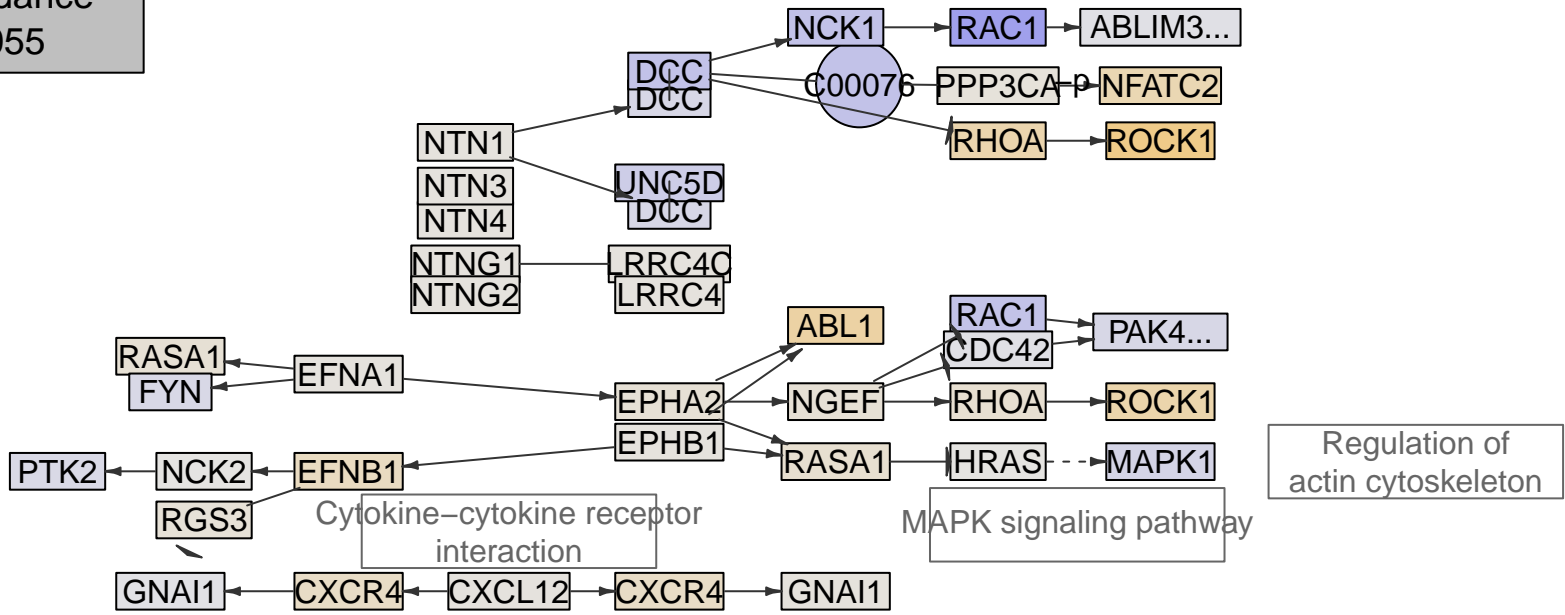

Axon guidance
MPI-065

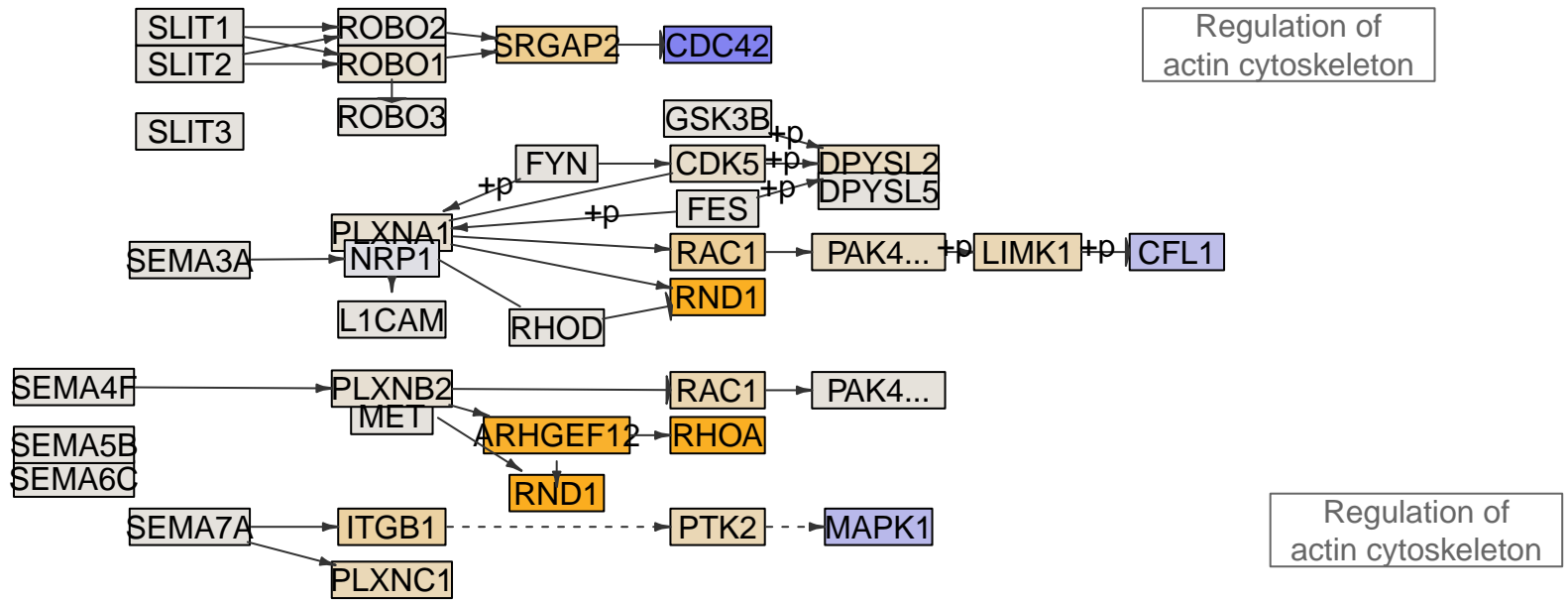
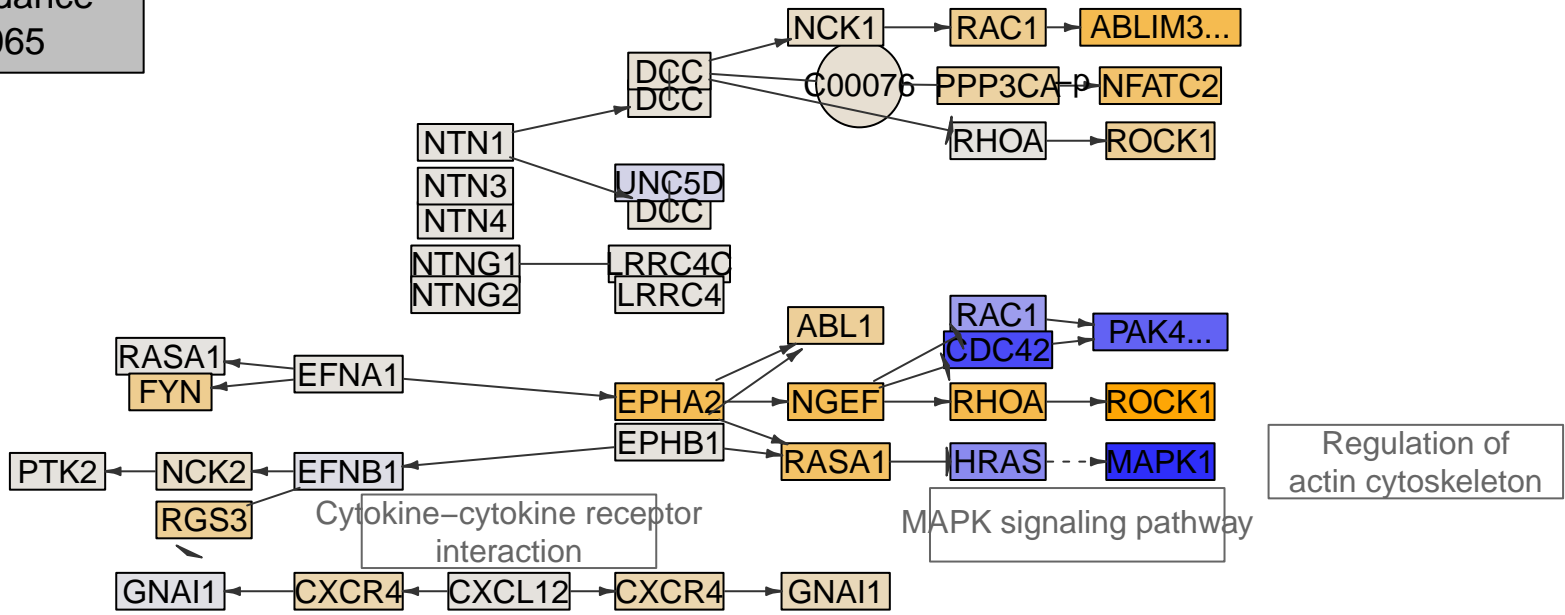

Axon guidance
MPI-071

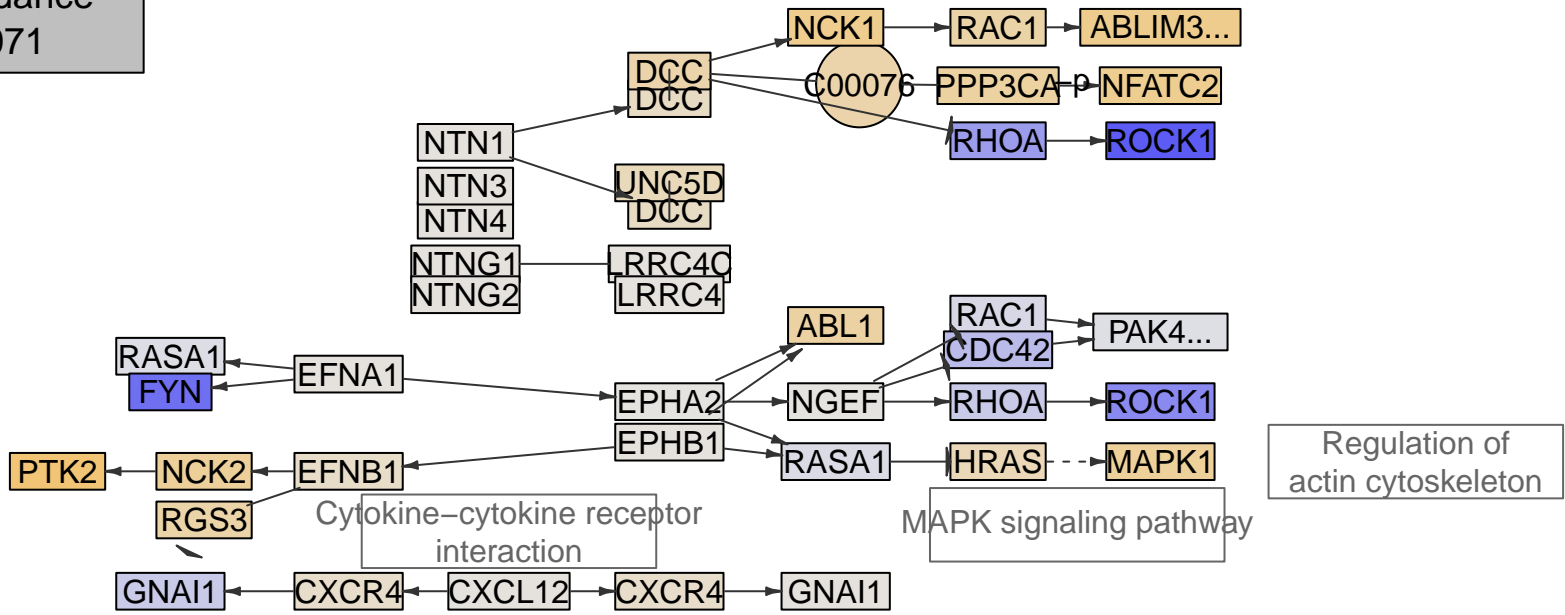

Regulation of actin cytoskeleton

MAPK signaling pathway

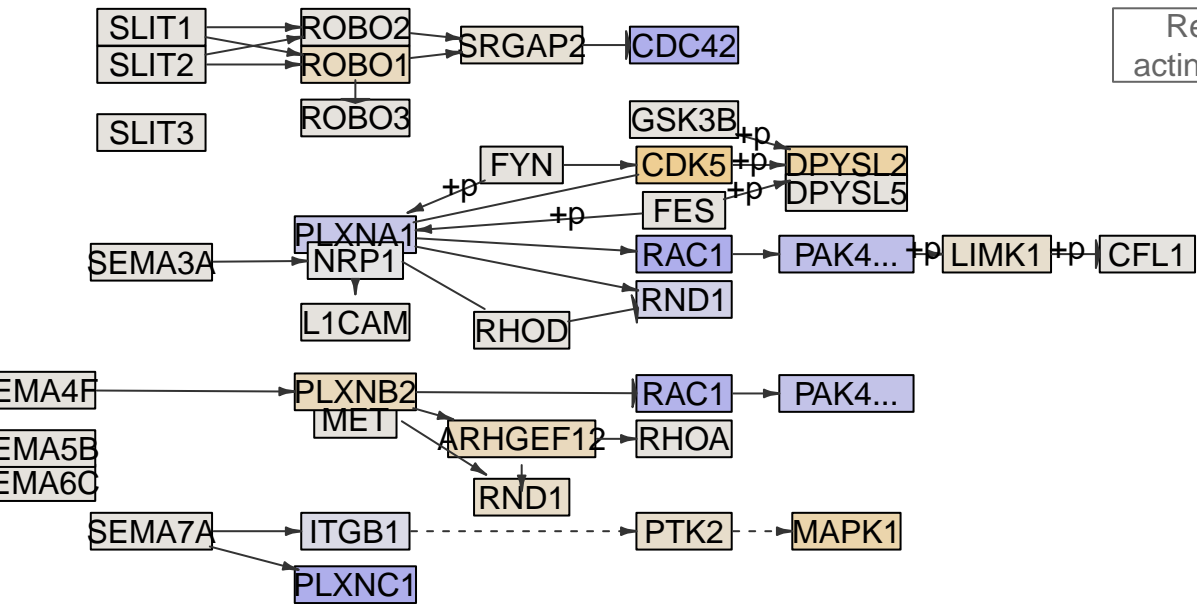

Regulation of actin cytoskeleton

Regulation of actin cytoskeleton

Axon guidance
MPI-075

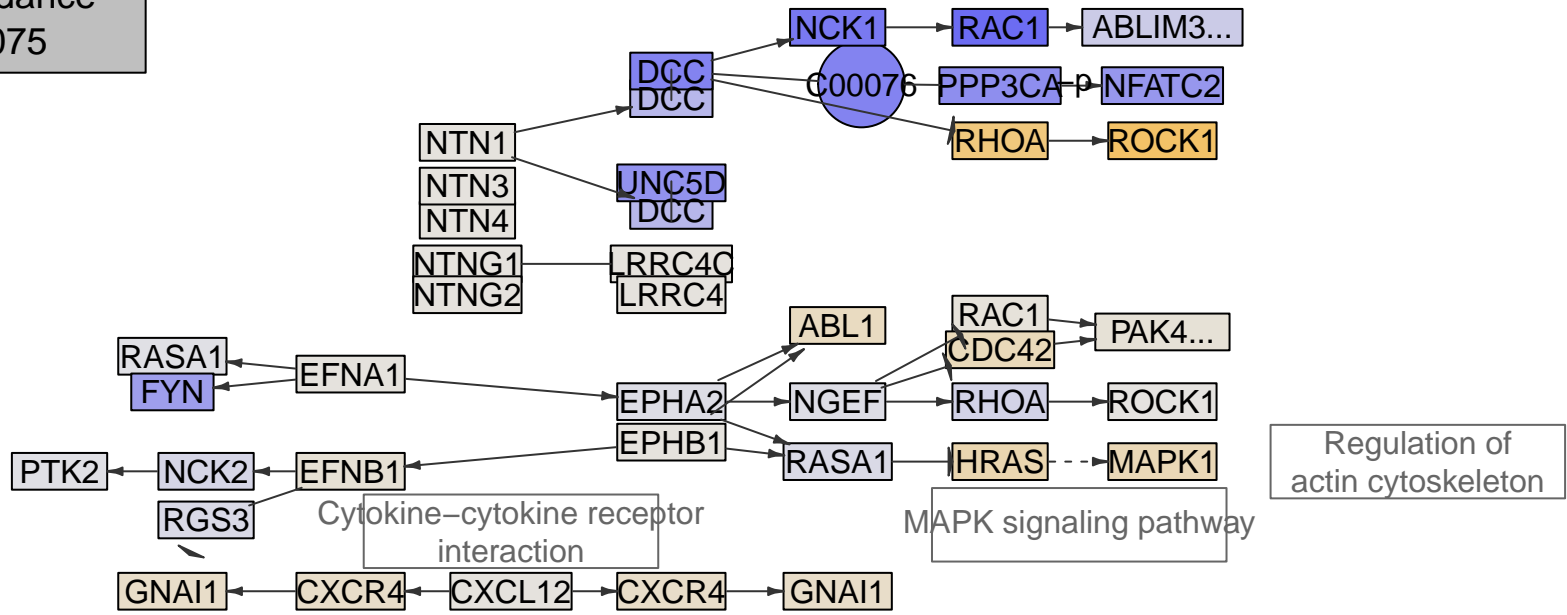

Regulation of actin cytoskeleton

MAPK signaling pathway

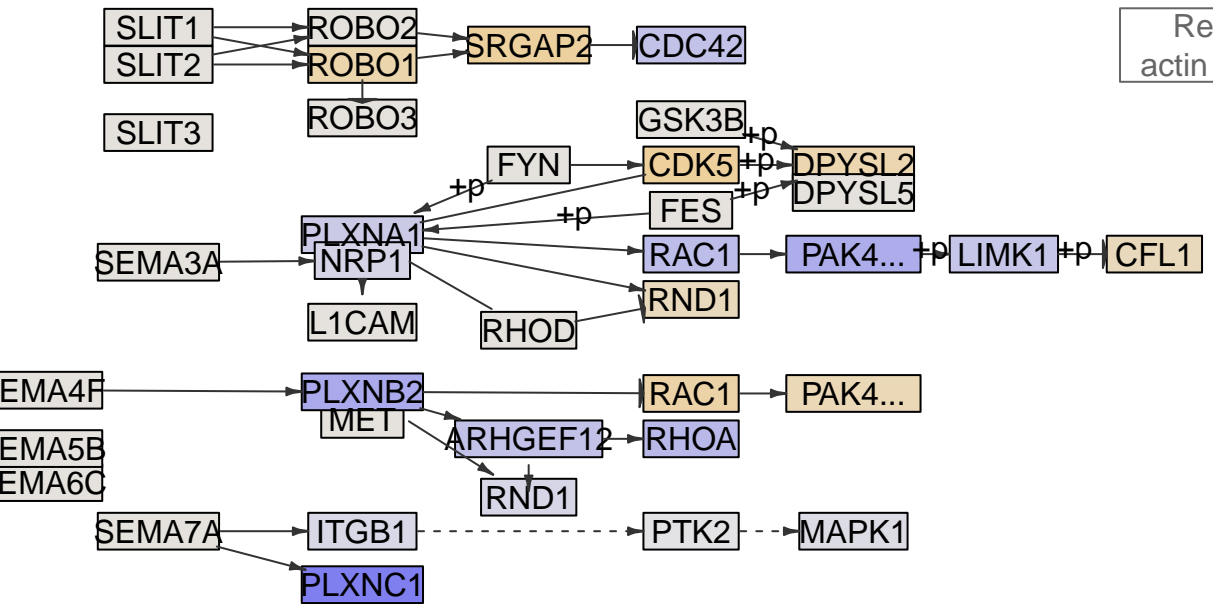

Regulation of actin cytoskeleton

Regulation of actin cytoskeleton

Axon guidance
MPI-077

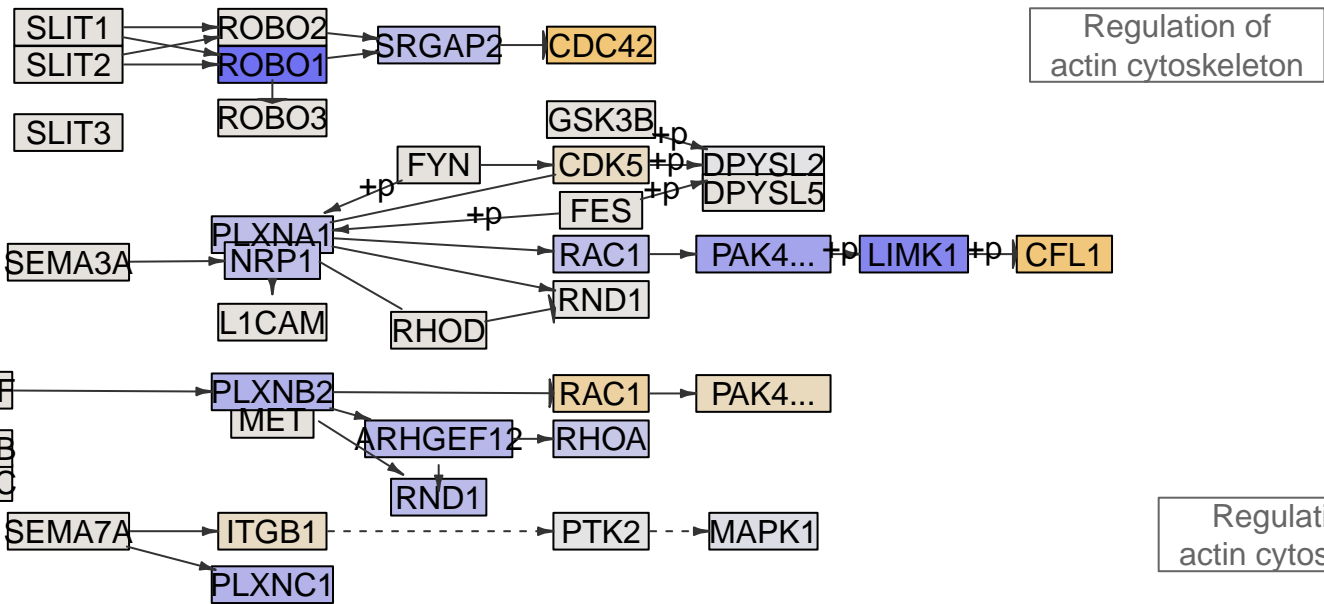
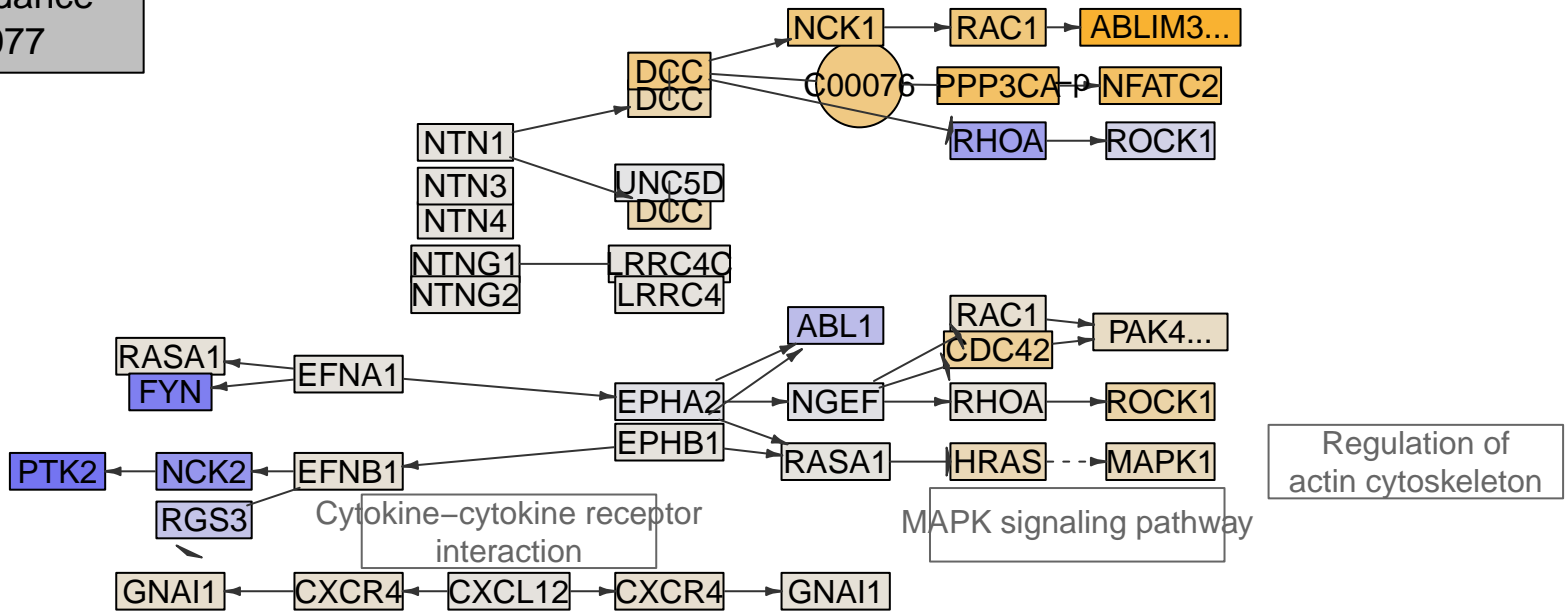

Axon guidance
MPI-078

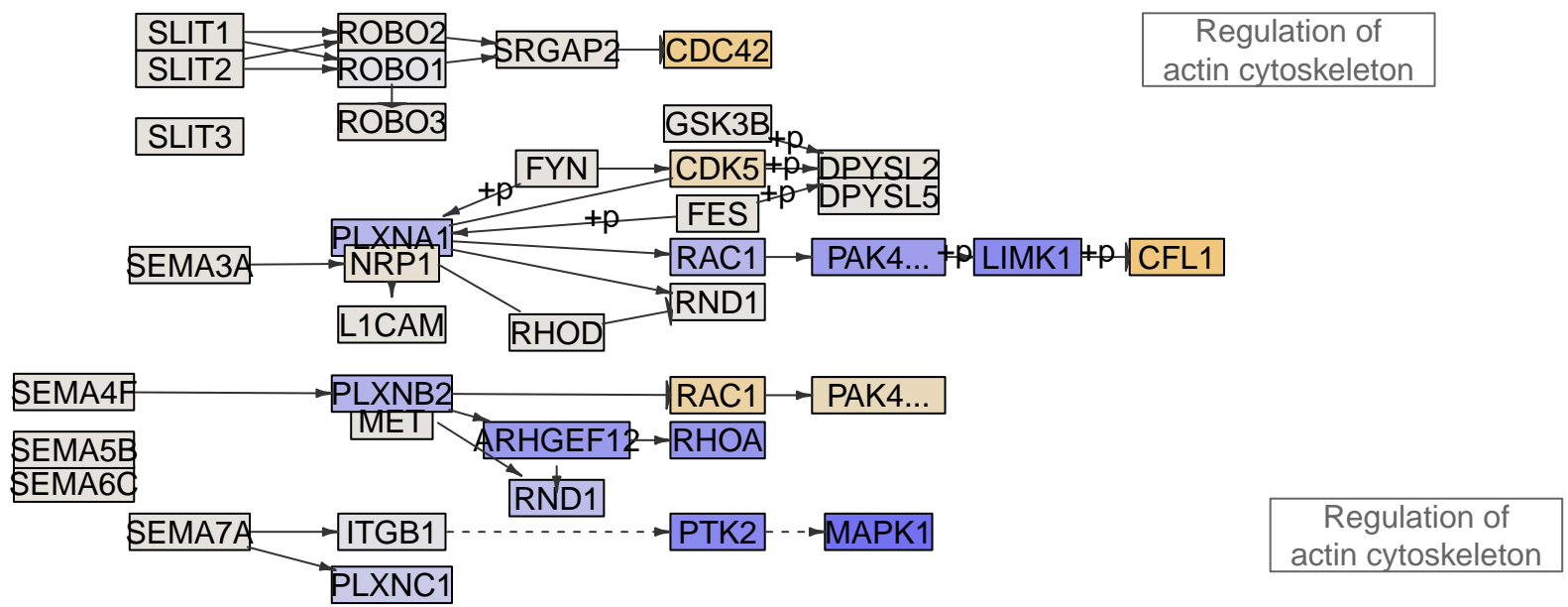
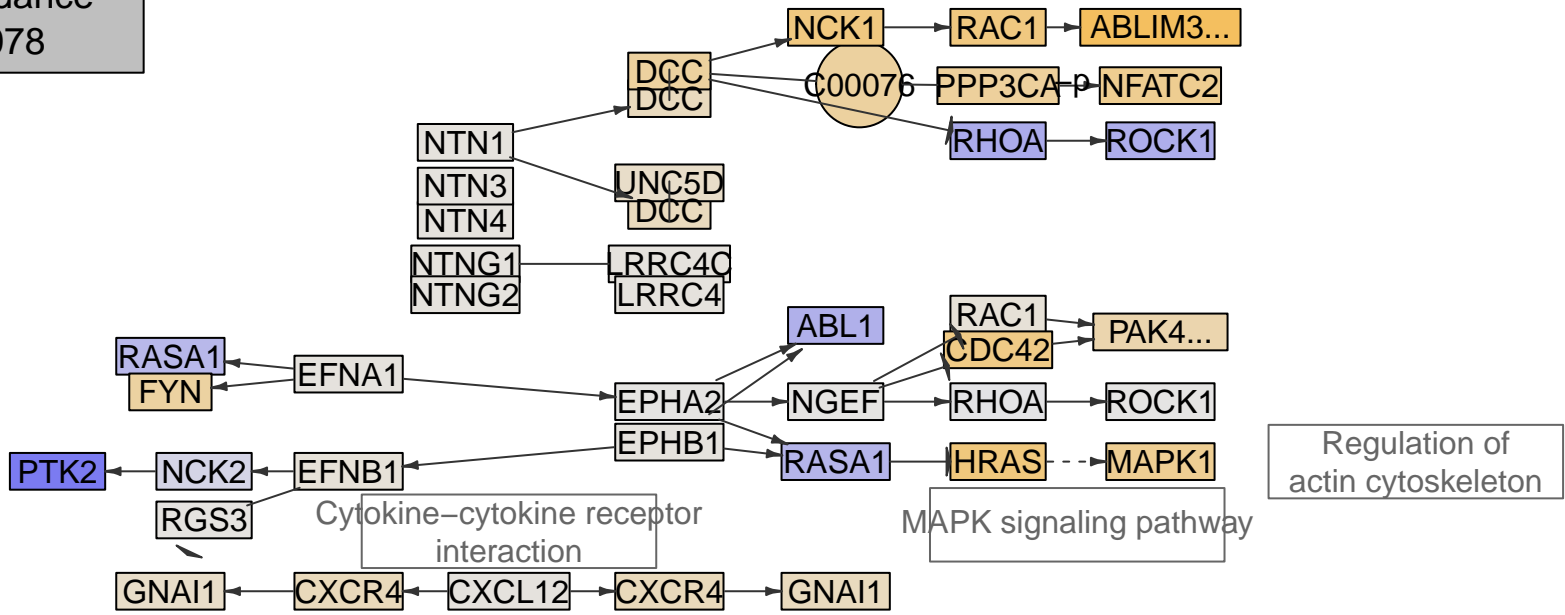

Axon guidance
MPI-079

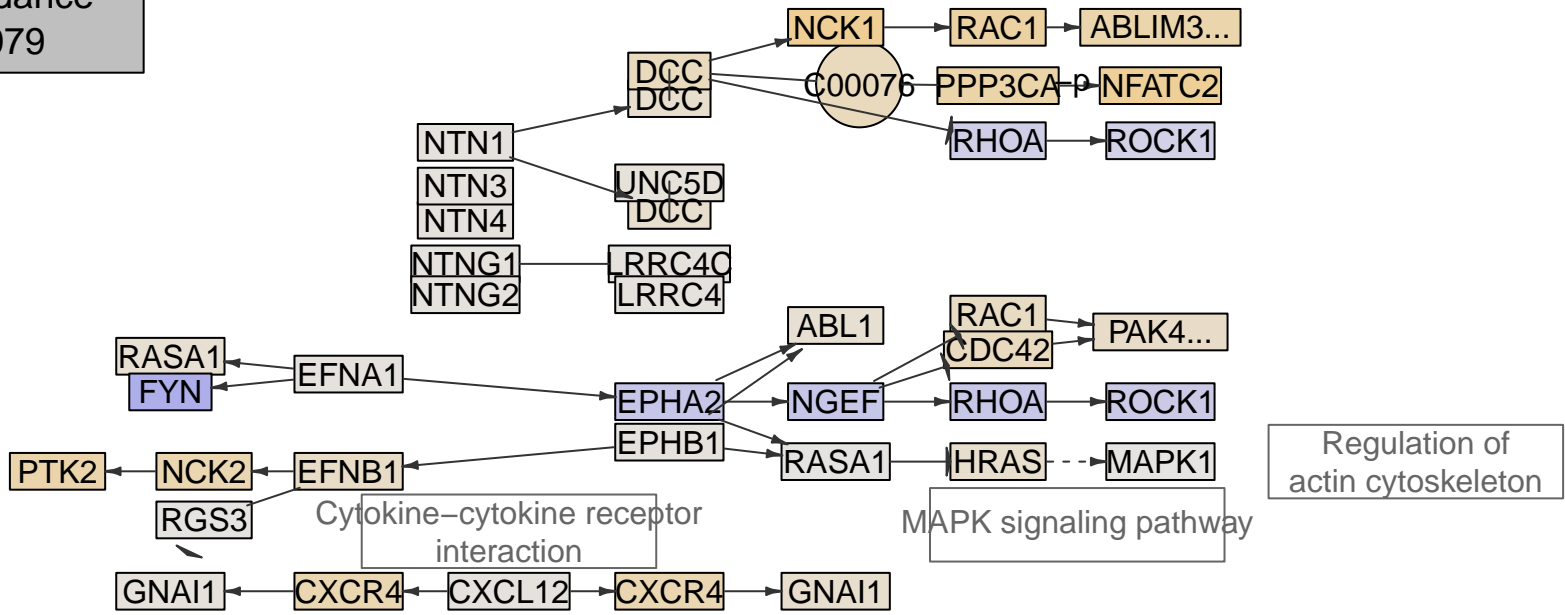

Regulation of actin cytoskeleton

MAPK signaling pathway

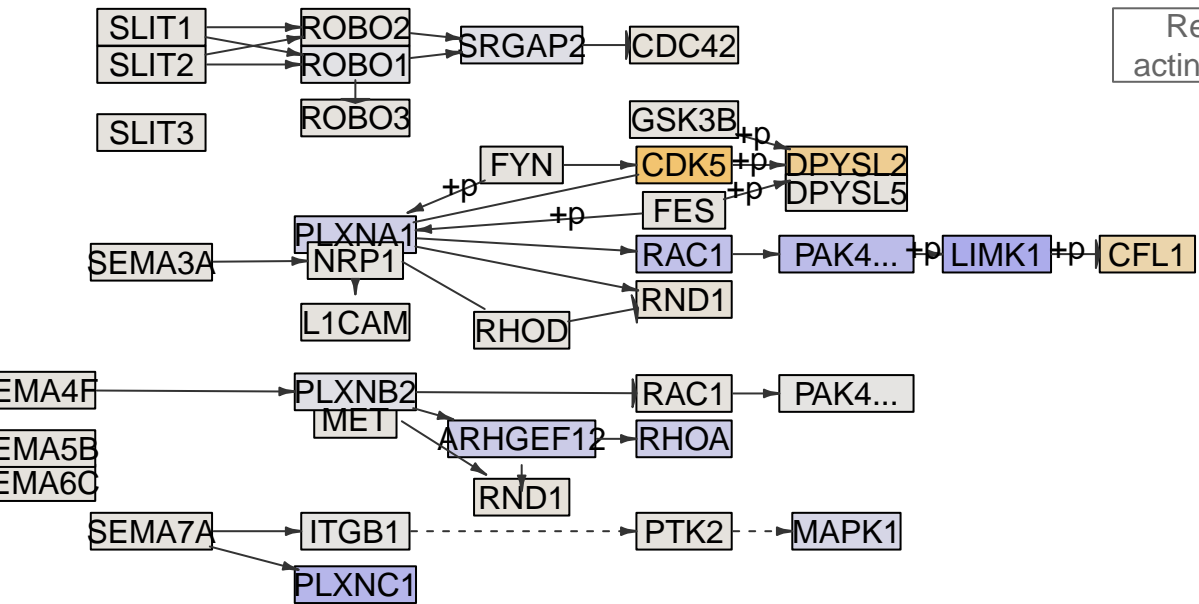

Regulation of actin cytoskeleton

Regulation of actin cytoskeleton

Axon guidance
MPI-080

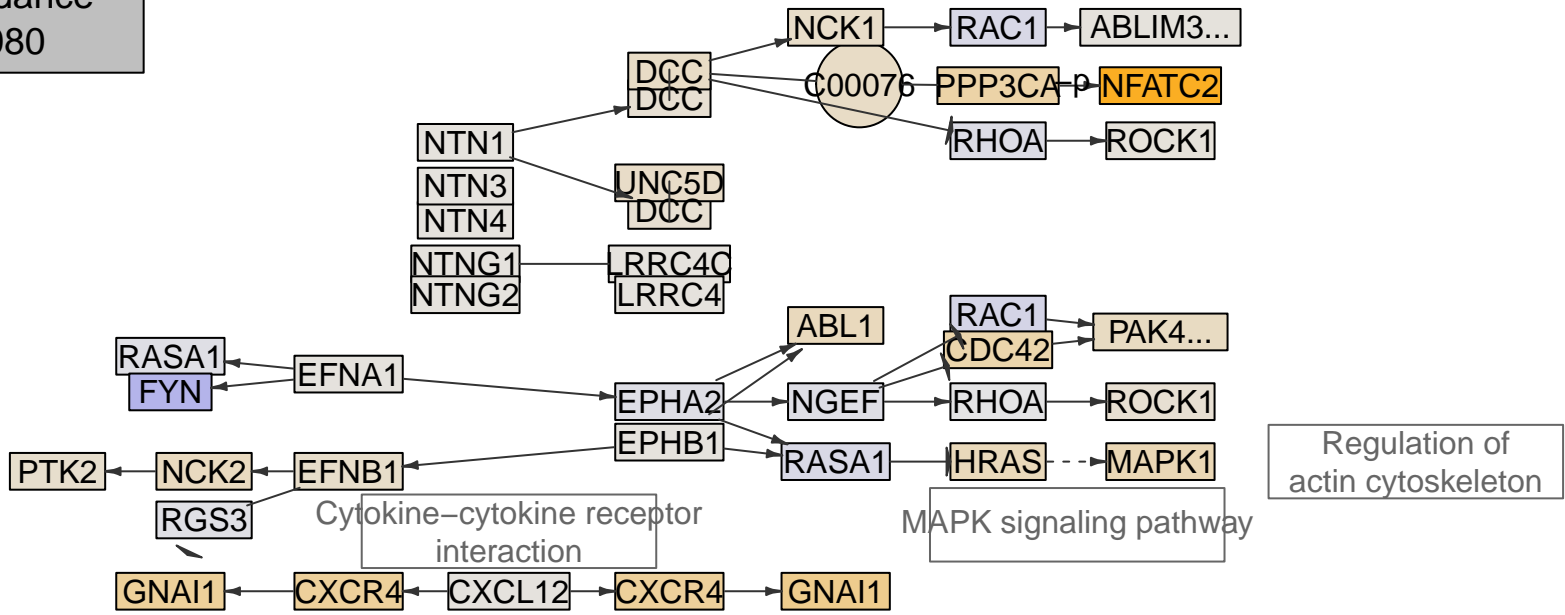

Regulation of actin cytoskeleton

MAPK signaling pathway

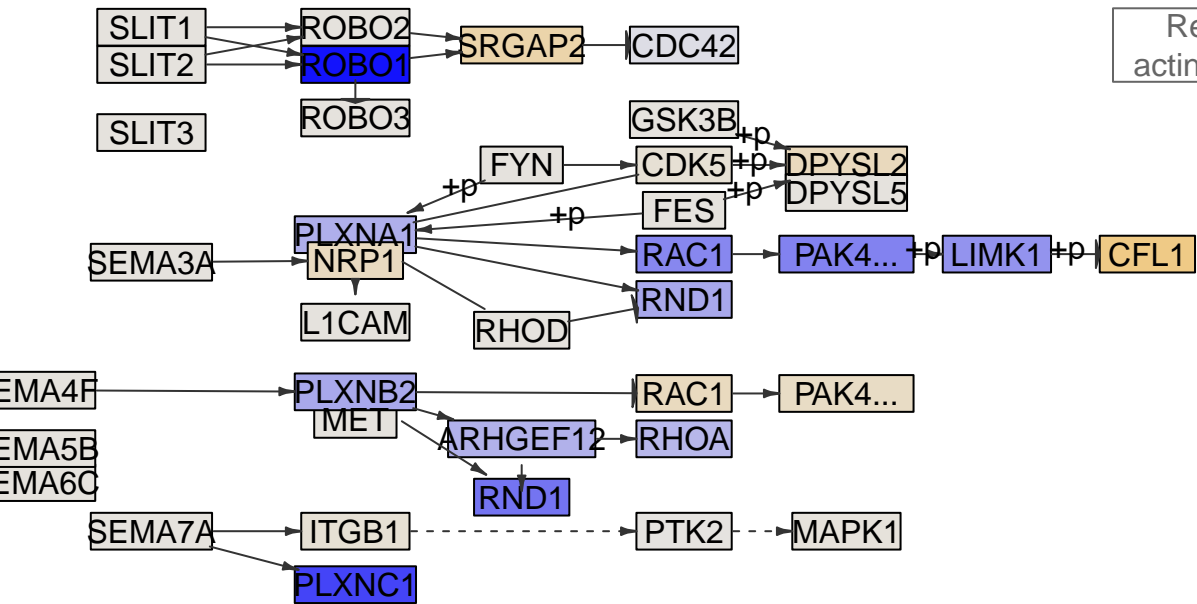

Regulation of actin cytoskeleton

Regulation of actin cytoskeleton

Axon guidance
MPI-081

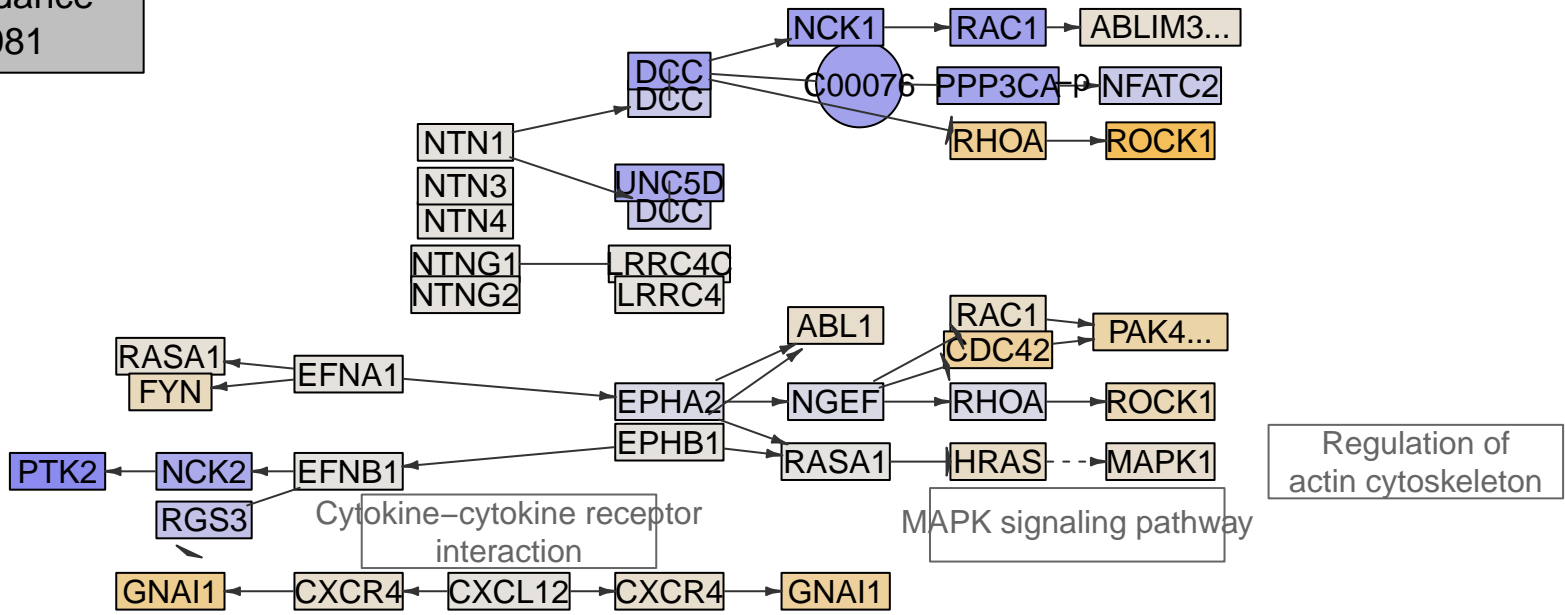

Regulation of actin cytoskeleton

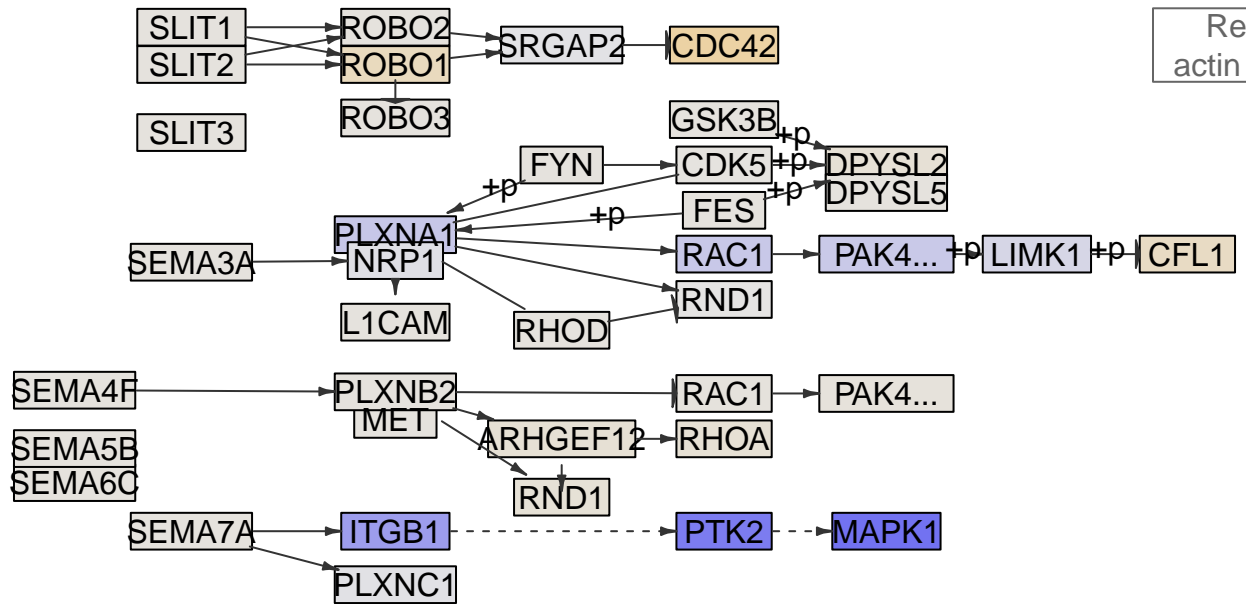

Regulation of actin cytoskeleton

Regulation of actin cytoskeleton

Axon guidance
MPI-082

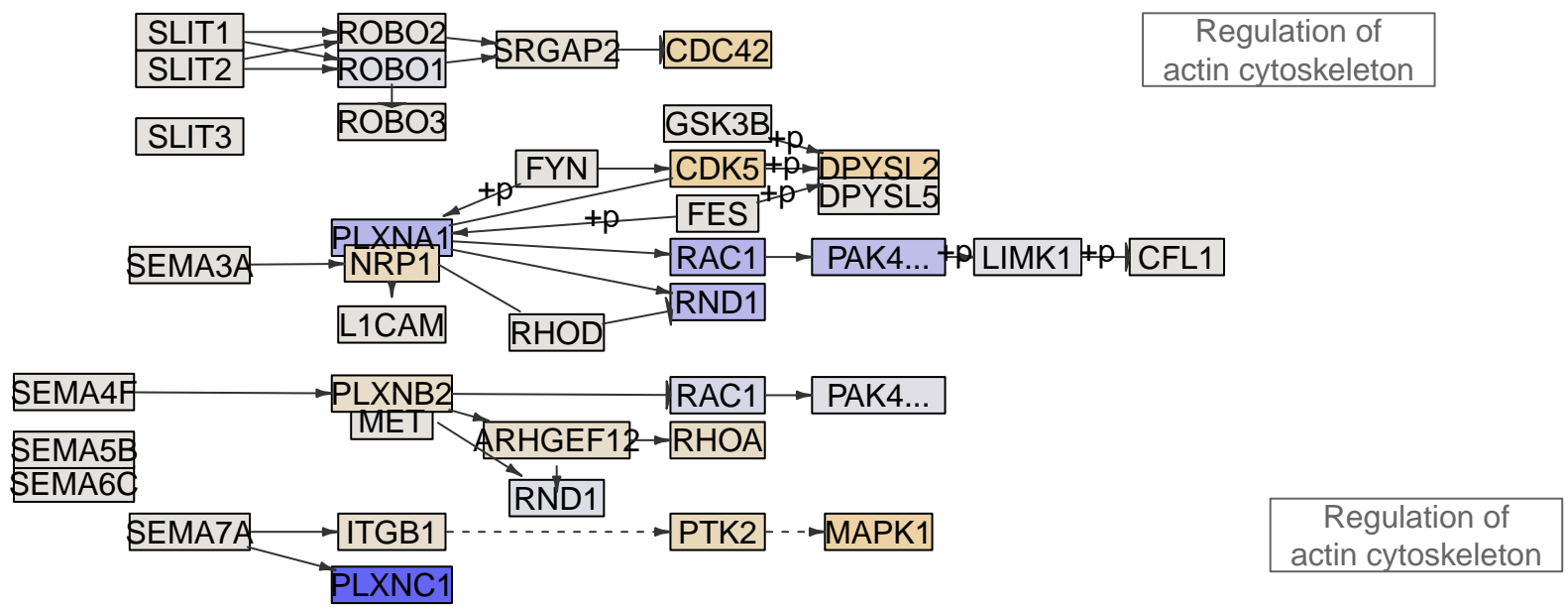
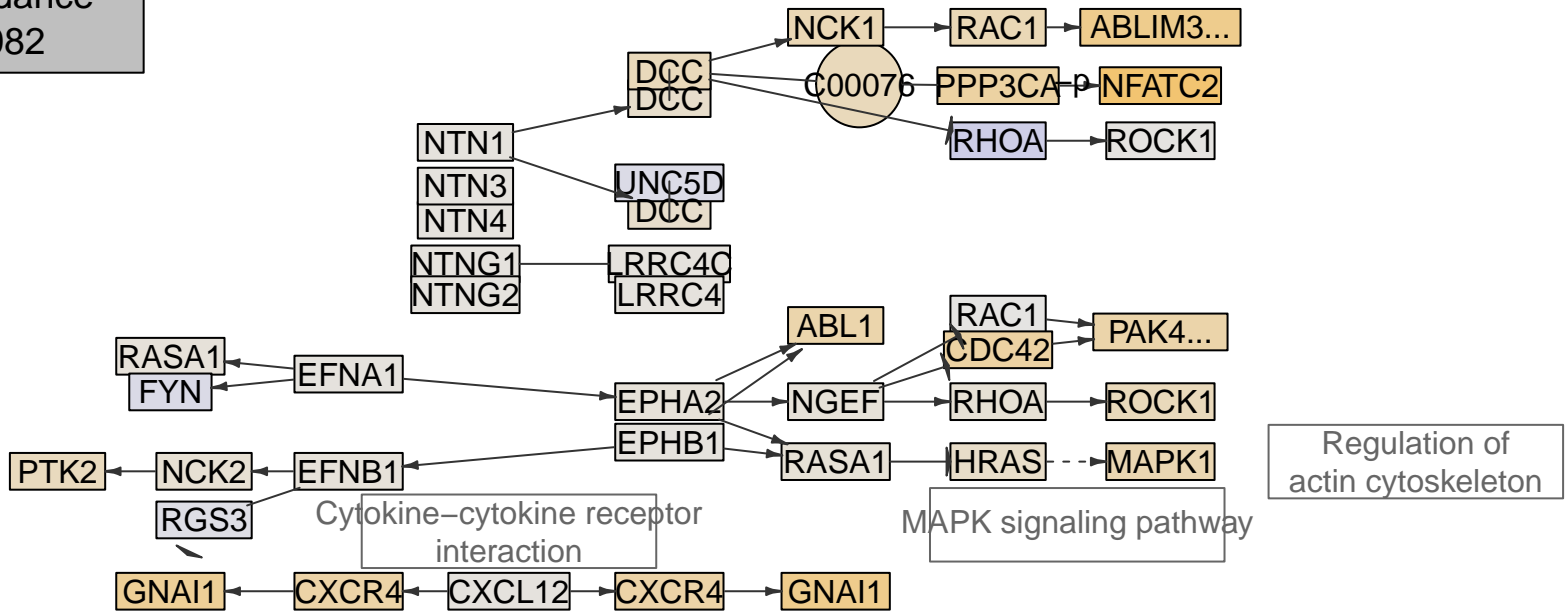

Axon guidance
MPI-084

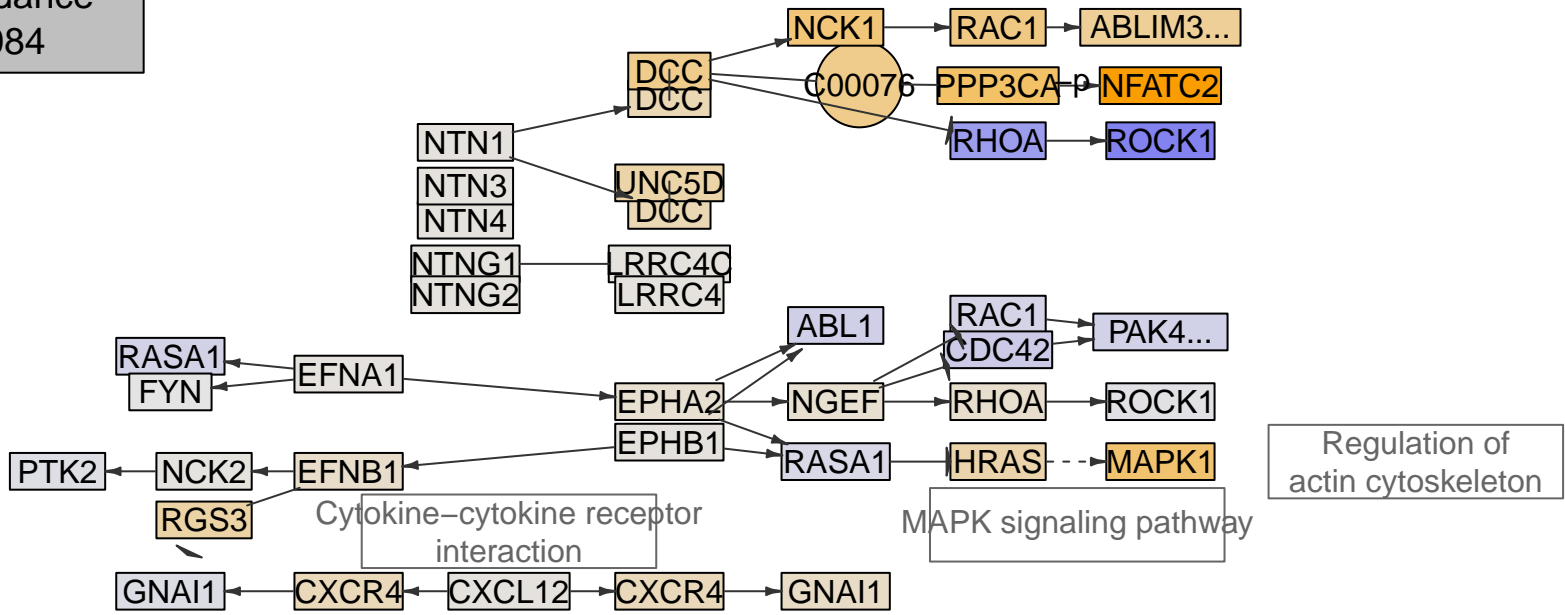

Regulation of actin cytoskeleton

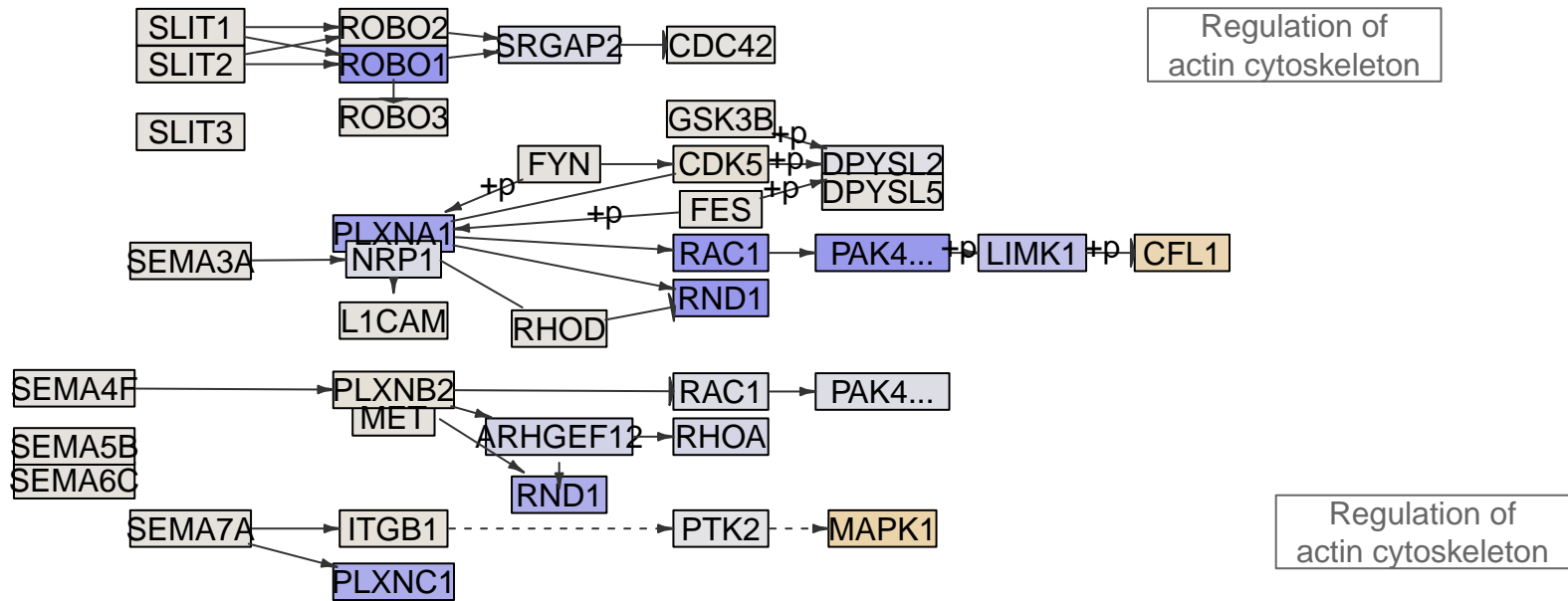

Regulation of actin cytoskeleton

Regulation of actin cytoskeleton

Axon guidance
MPI-085

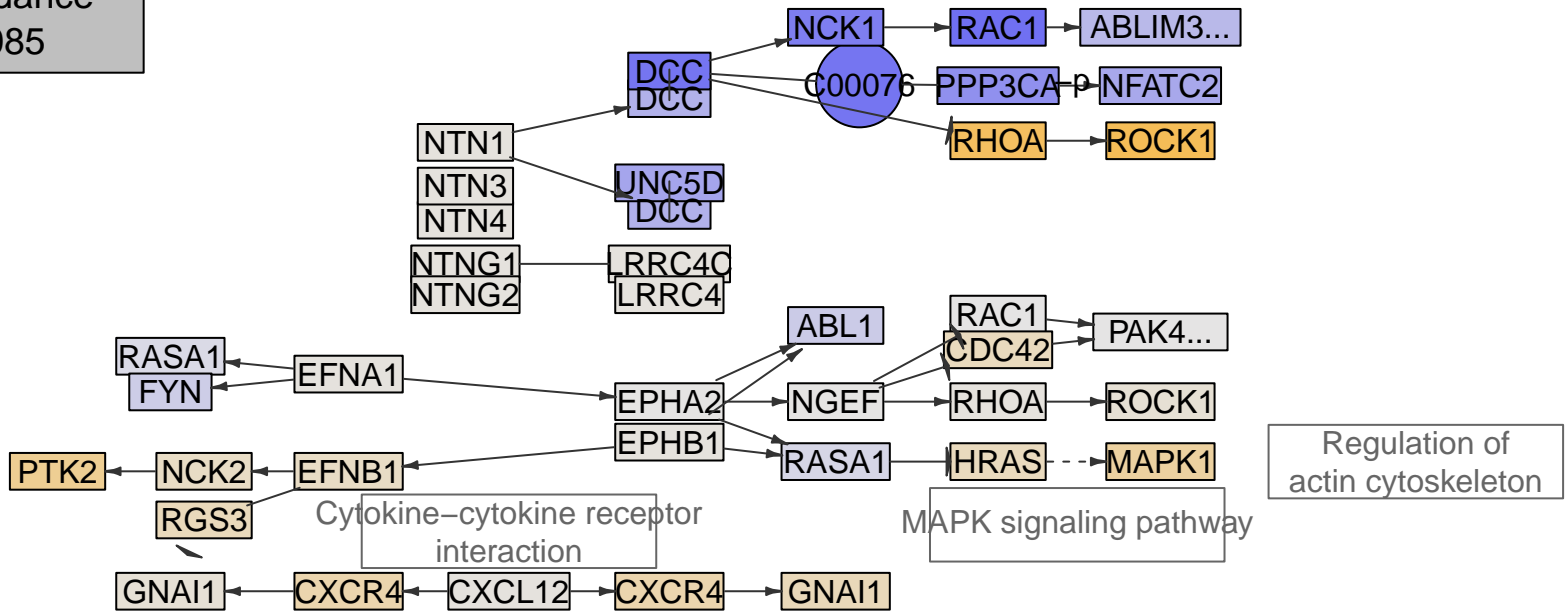

Regulation of actin cytoskeleton

MAPK signaling pathway

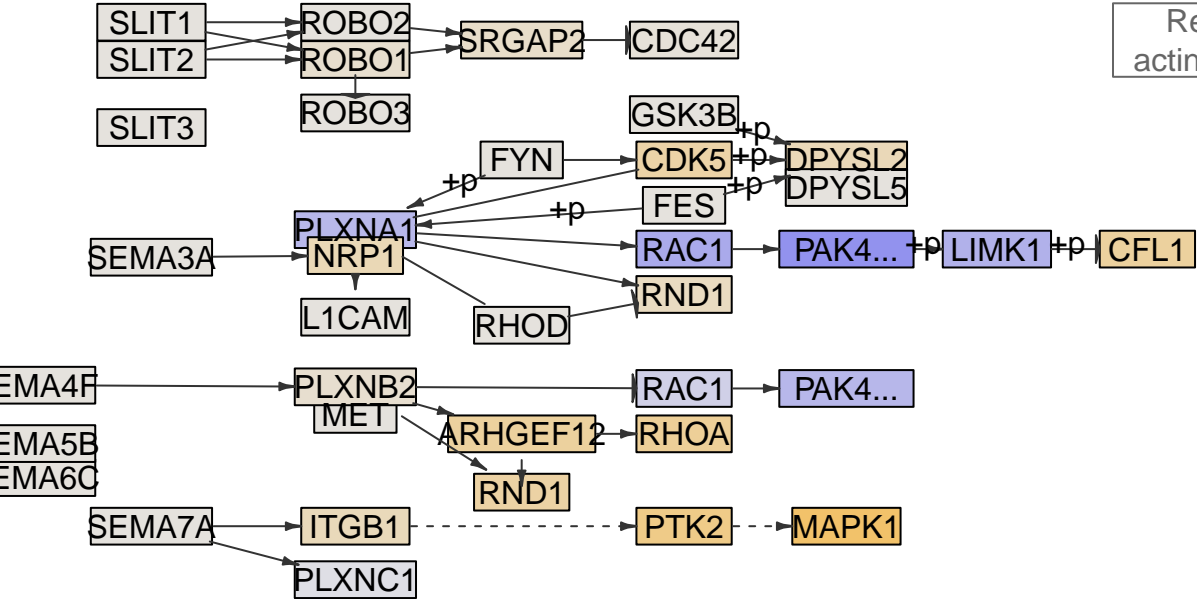

Regulation of actin cytoskeleton

Regulation of actin cytoskeleton

Axon guidance
MPI-086

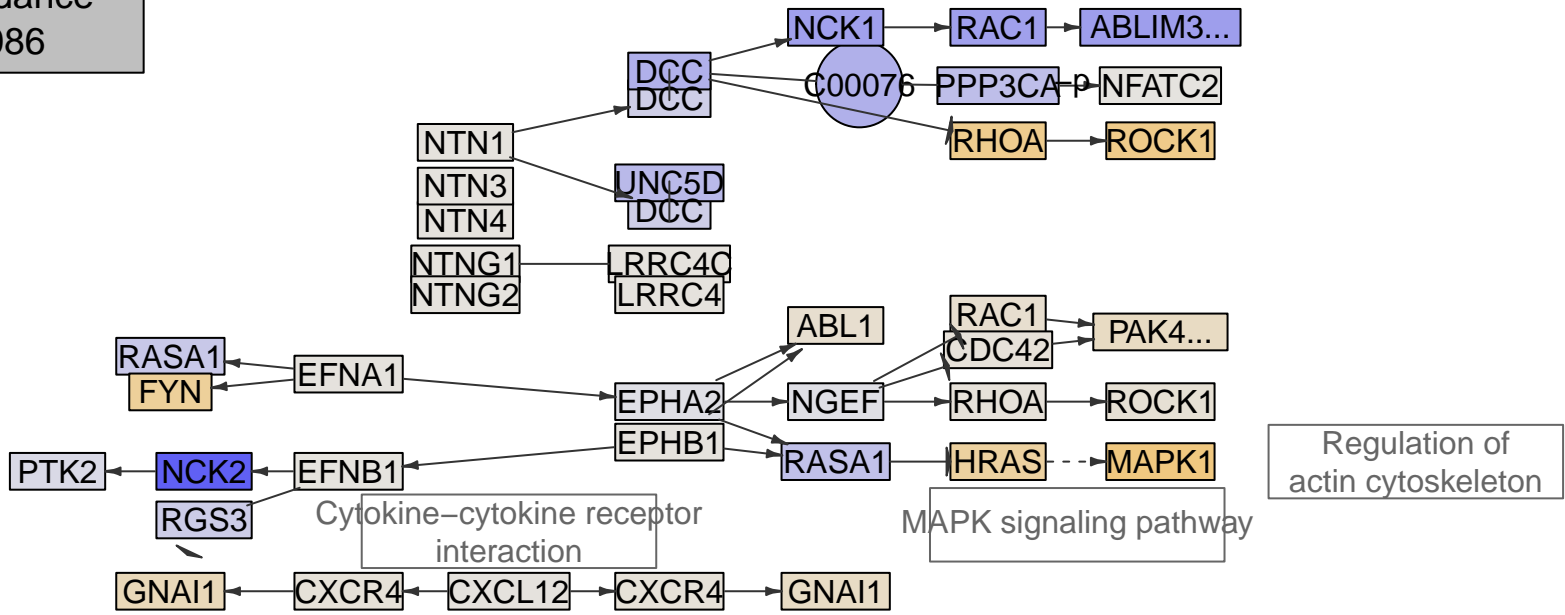

Regulation of actin cytoskeleton

MAPK signaling pathway

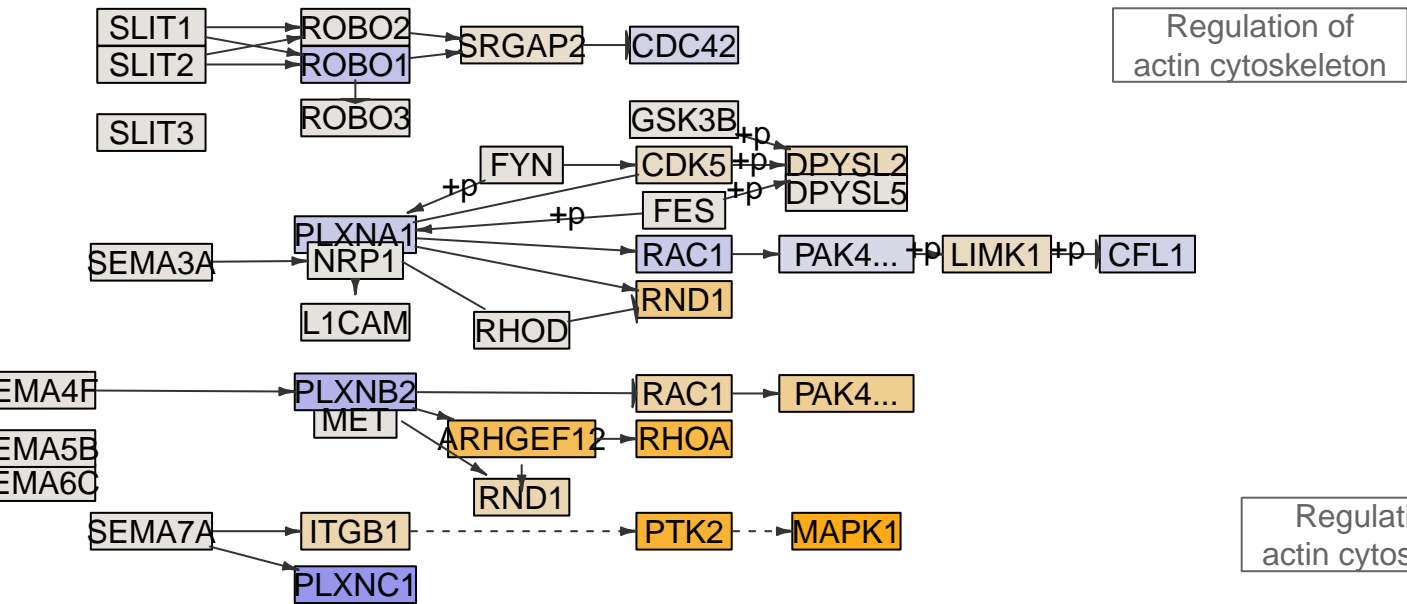

Regulation of actin cytoskeleton

Regulation of actin cytoskeleton

Axon guidance
MPI-087

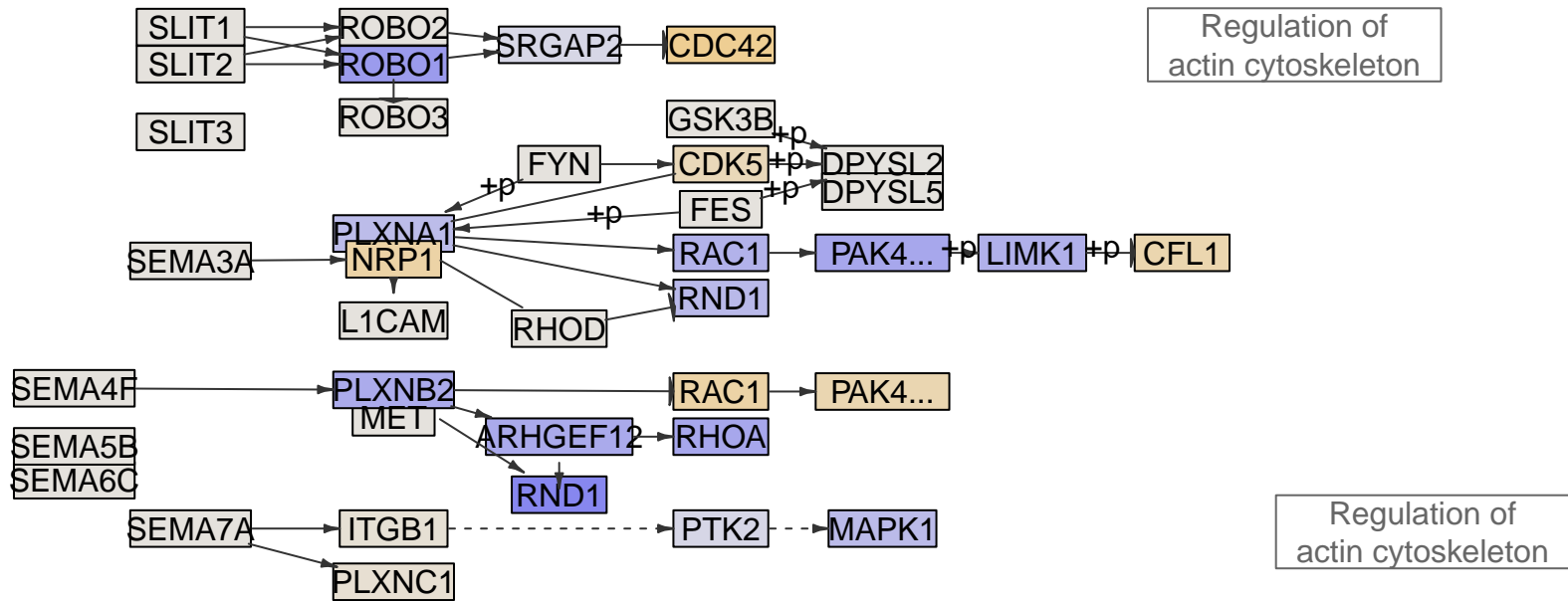
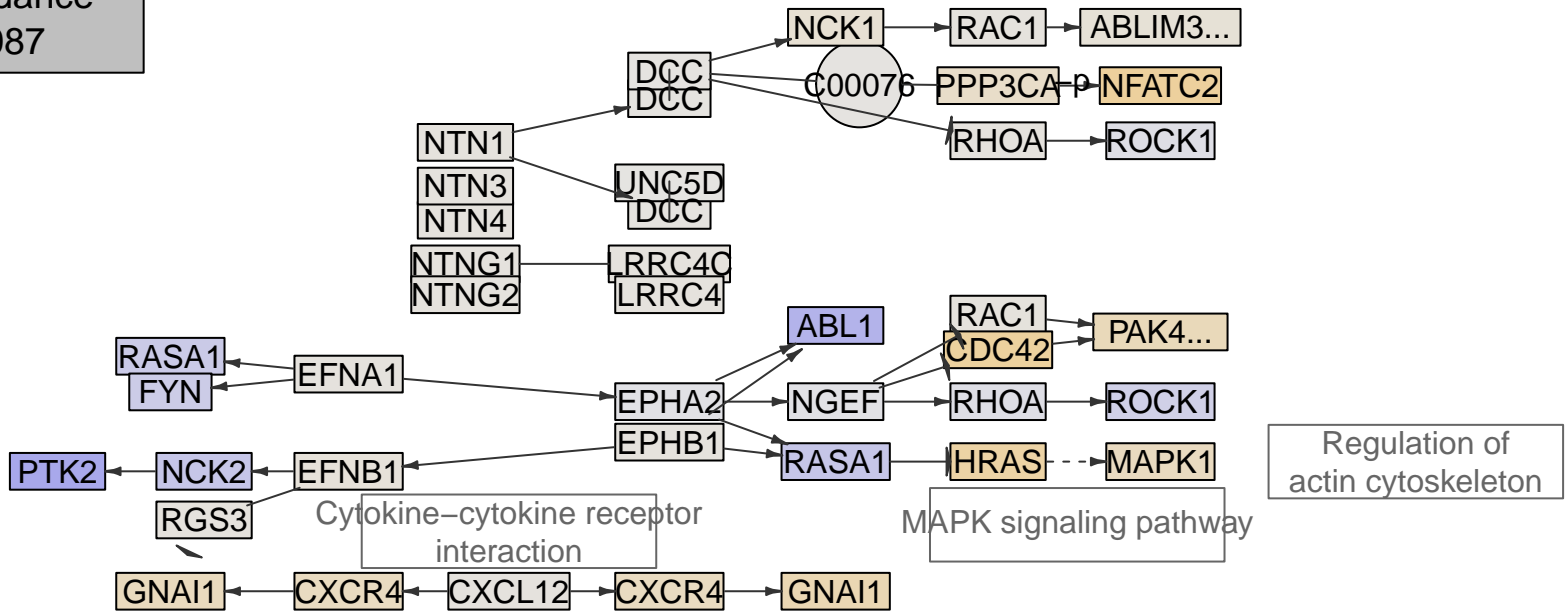

Axon guidance
MPI-089

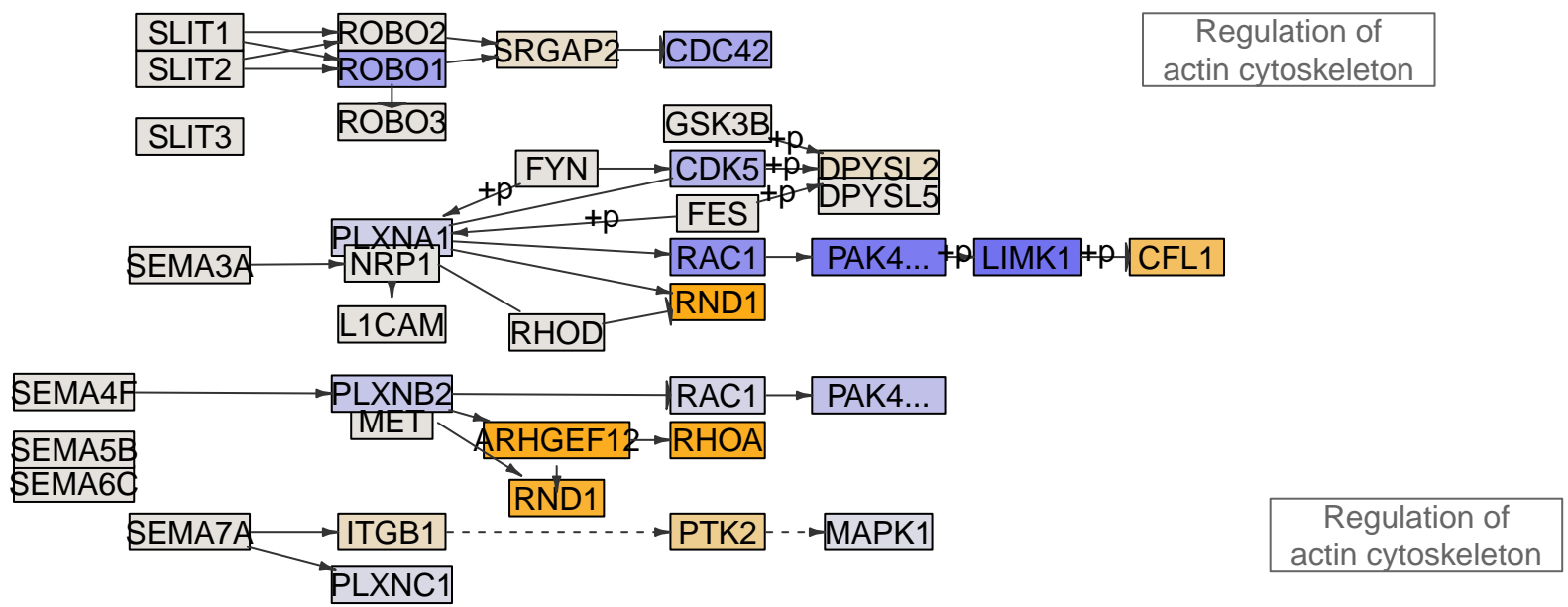
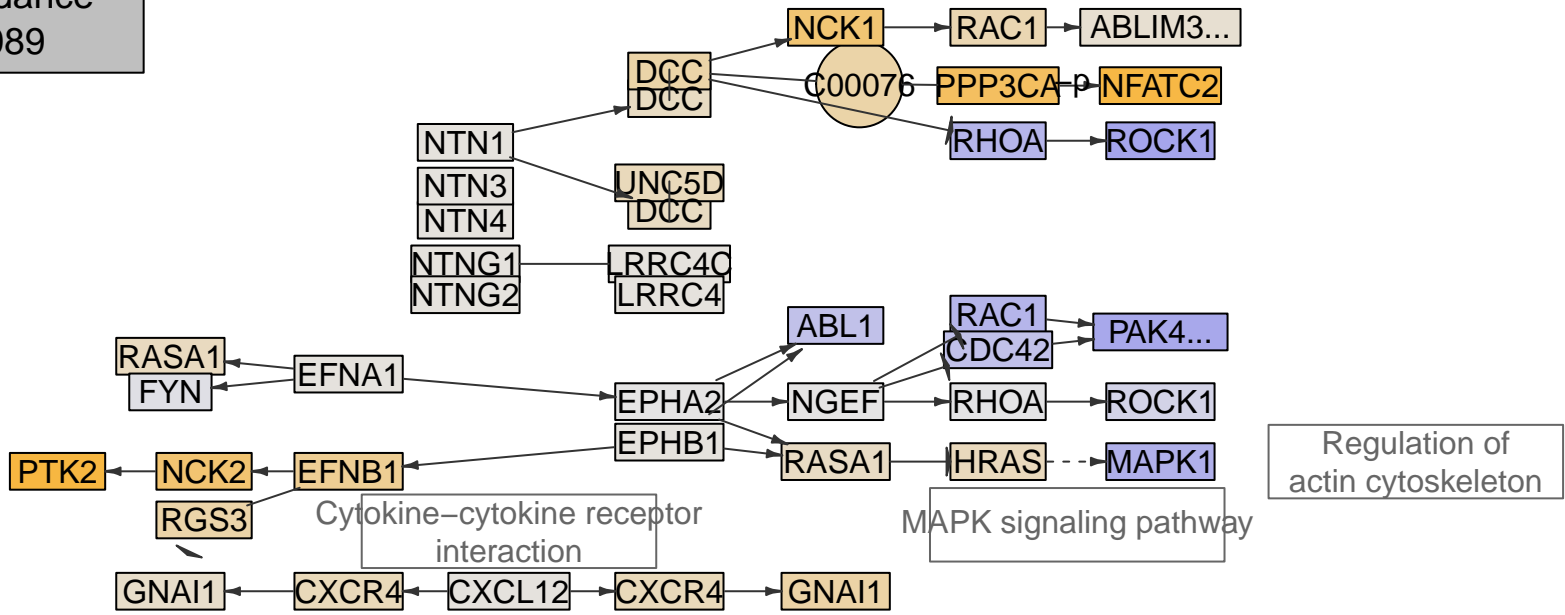

Axon guidance
MPI-090

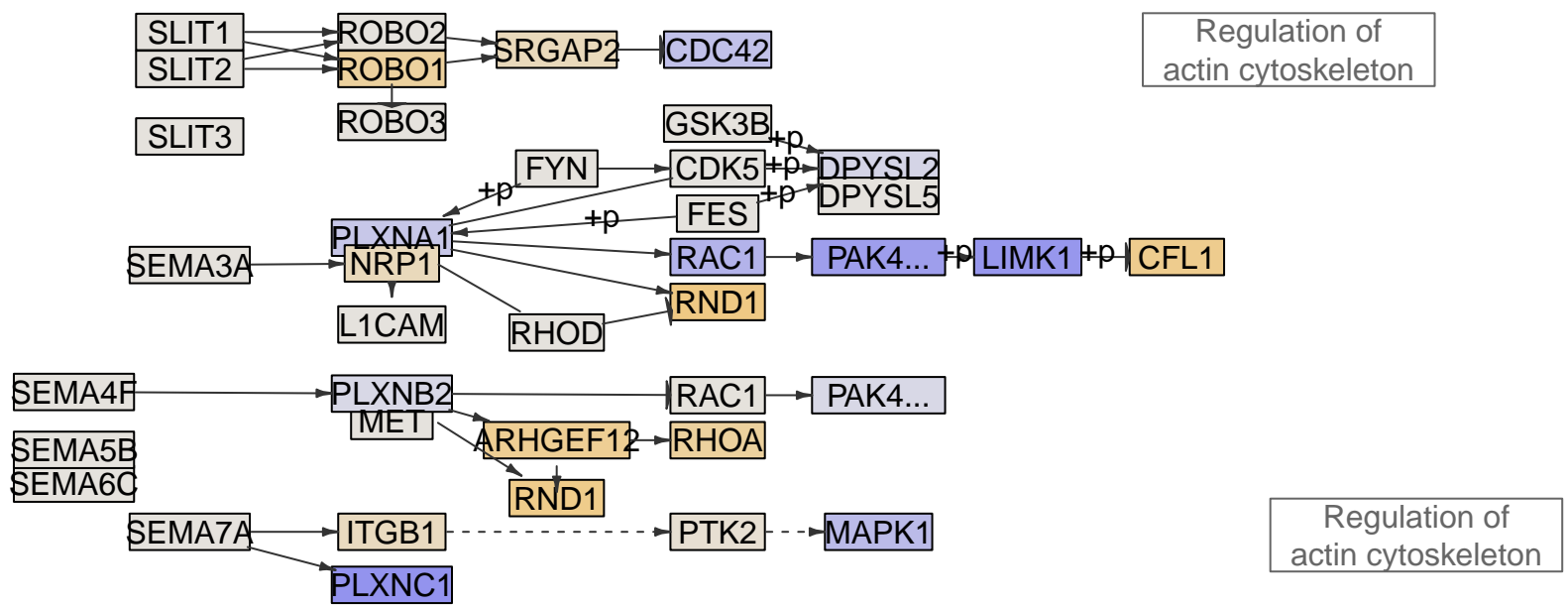
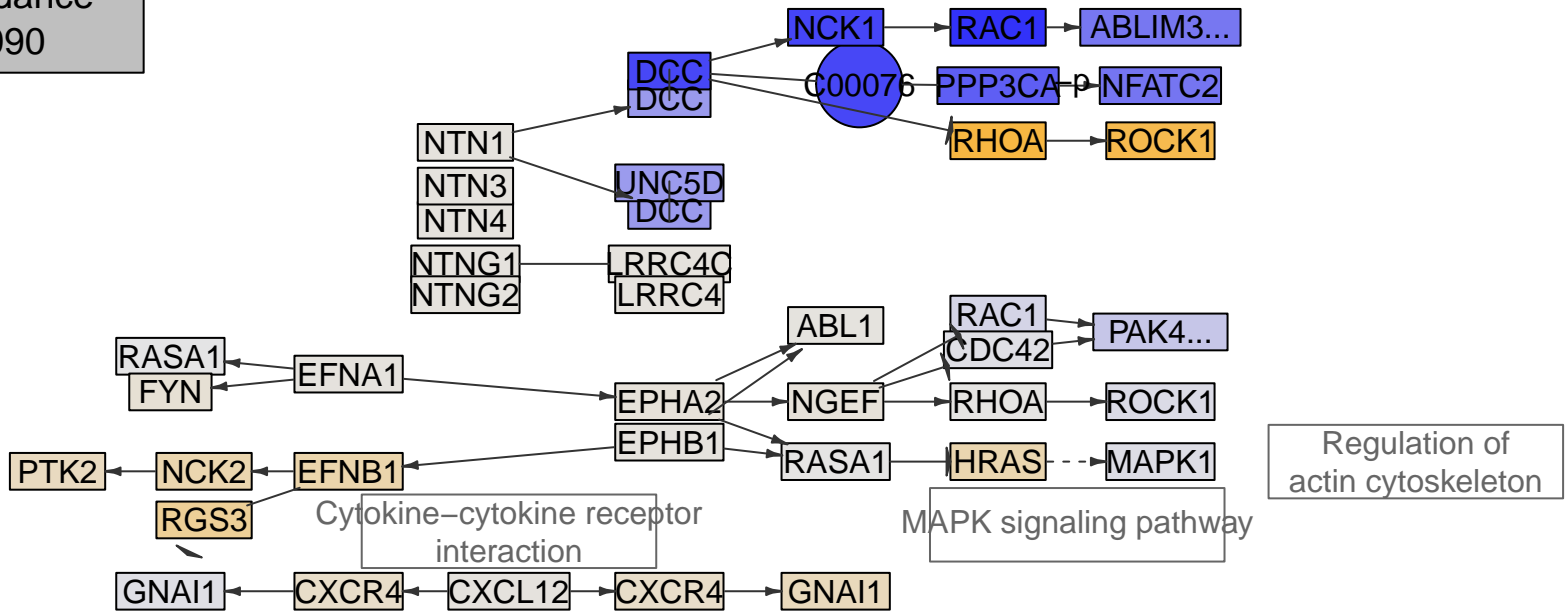

Axon guidance
MPI-091

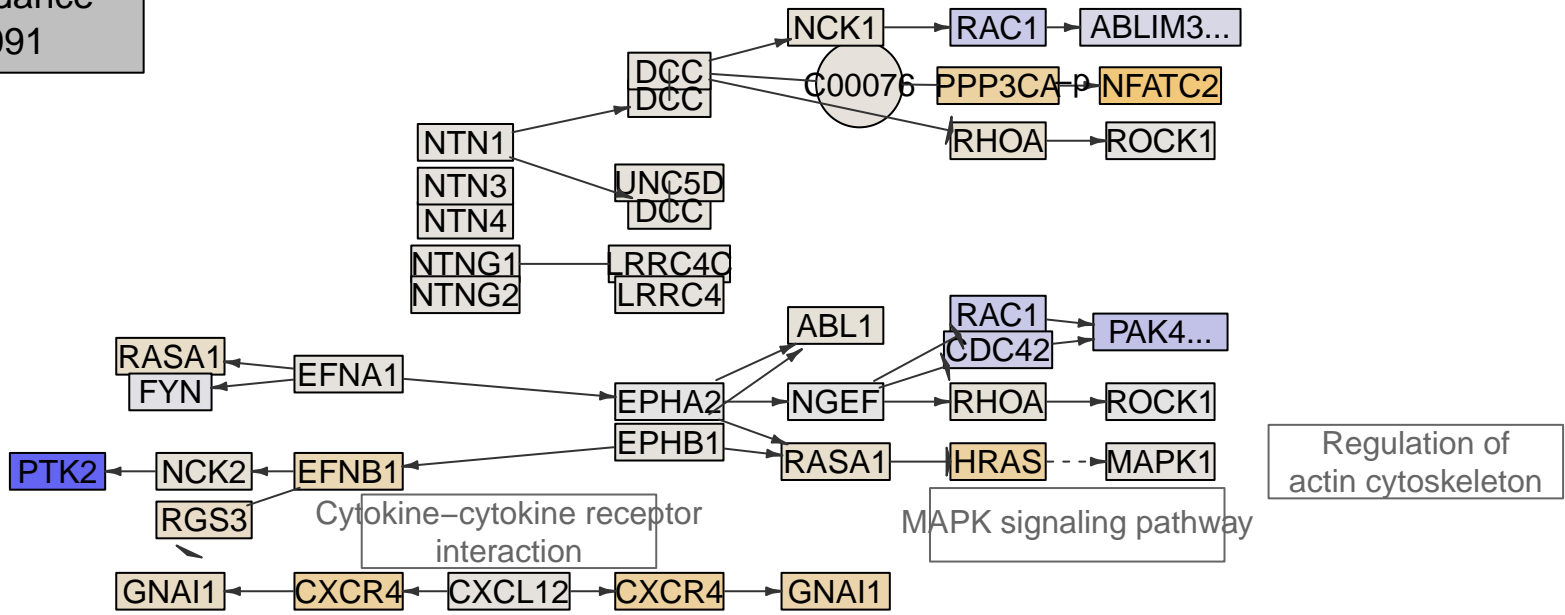

Regulation of actin cytoskeleton

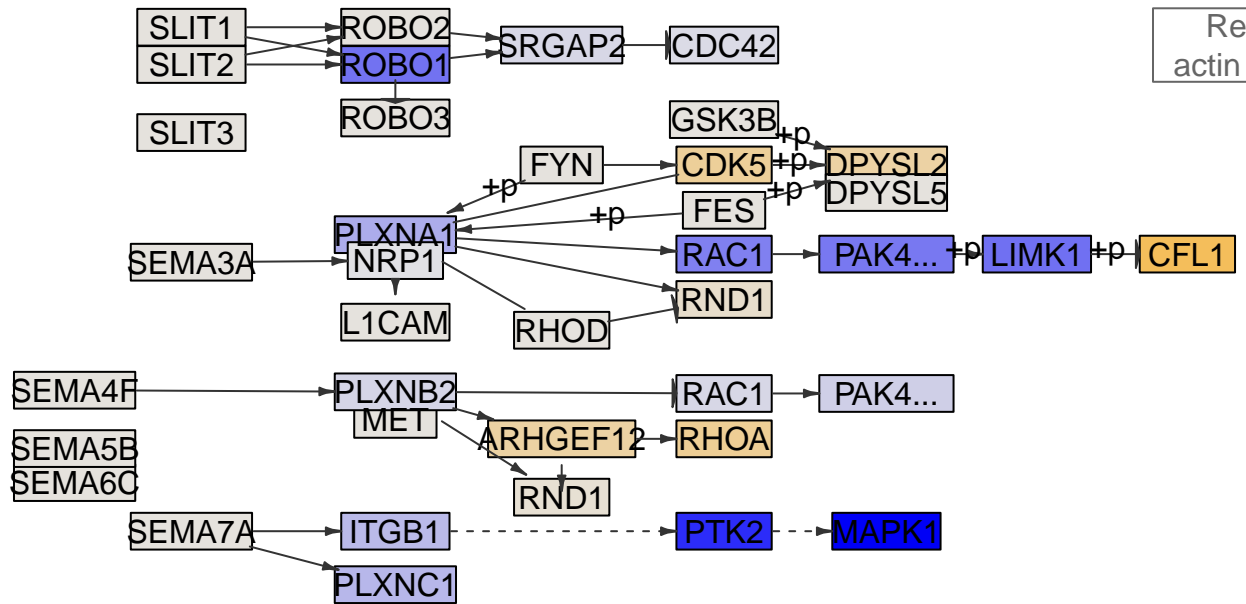

Regulation of actin cytoskeleton

Regulation of actin cytoskeleton

Axon guidance
MPI-095

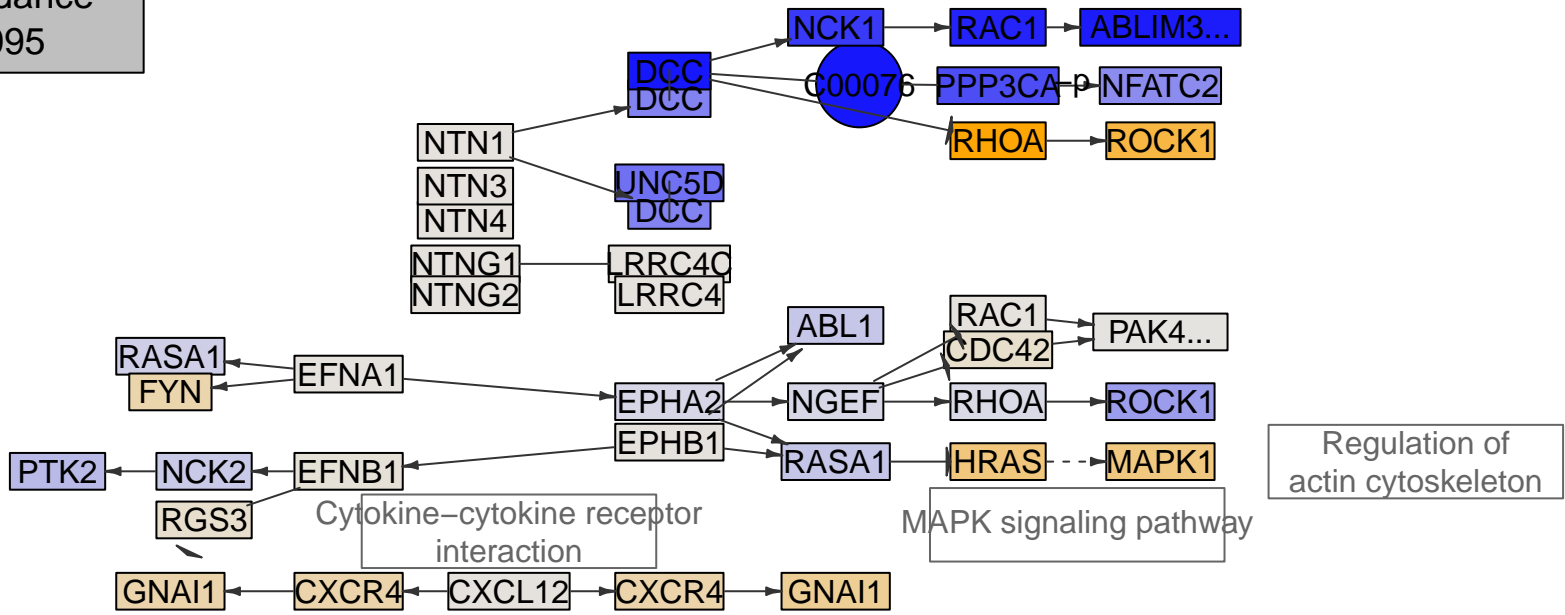

Regulation of actin cytoskeleton

MAPK signaling pathway

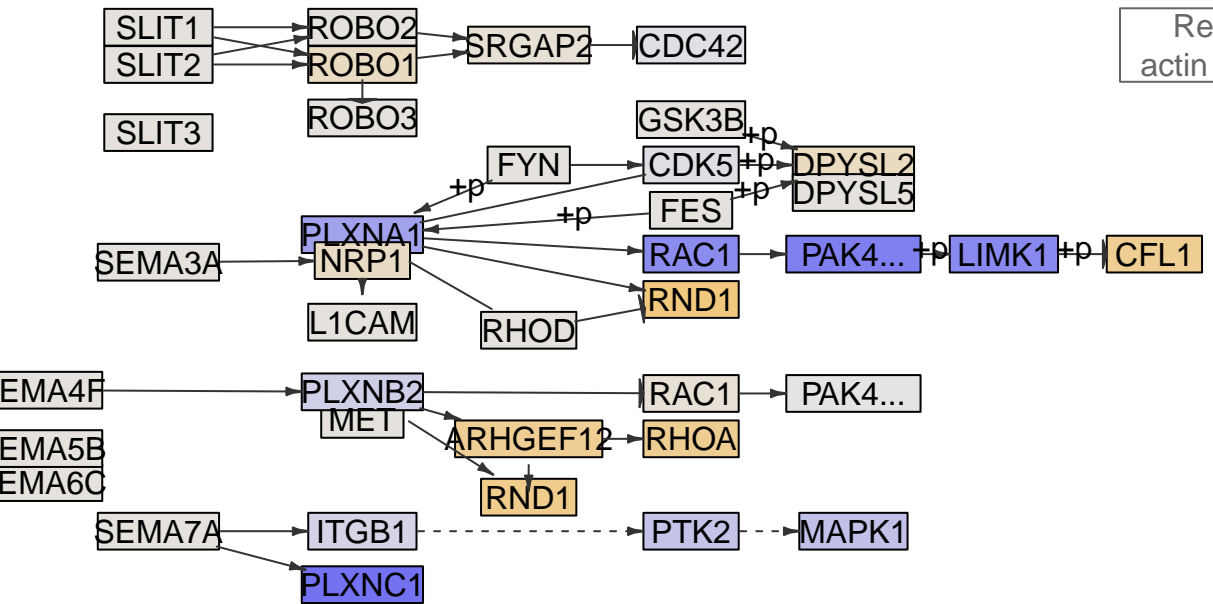

Regulation of actin cytoskeleton

Regulation of actin cytoskeleton

Axon guidance
MPI-101

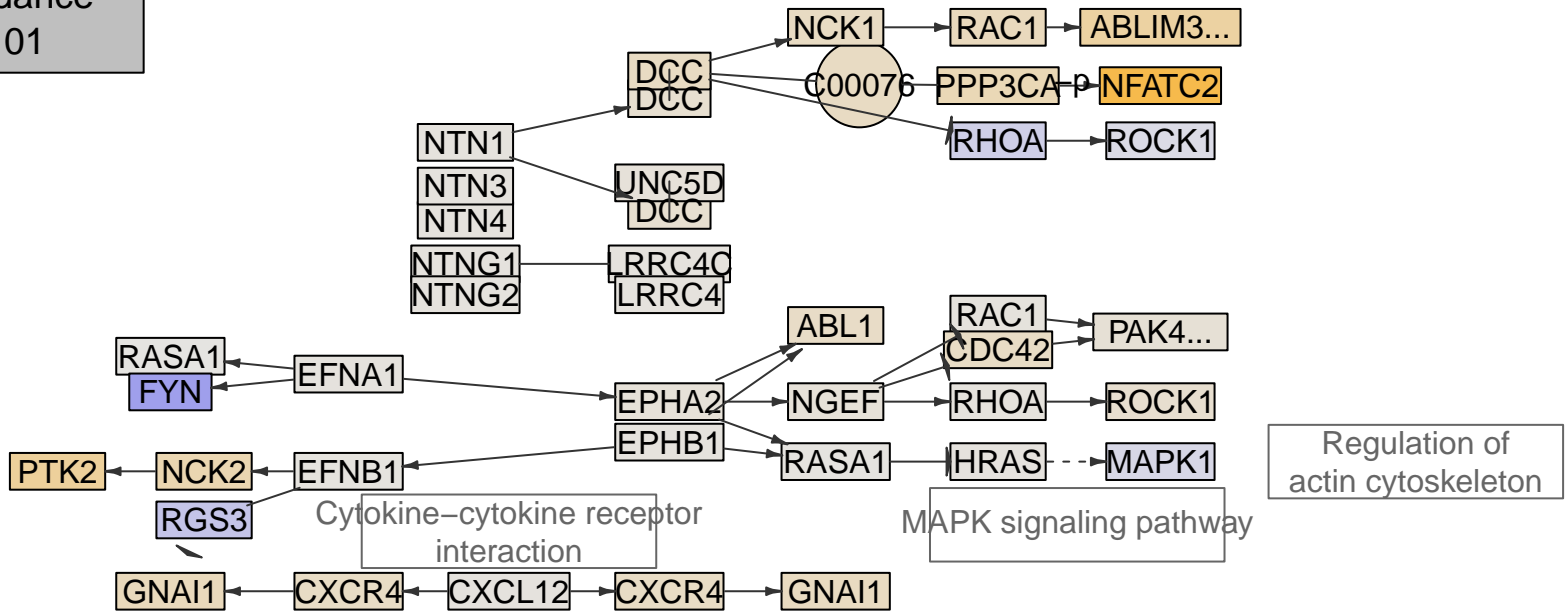

Regulation of actin cytoskeleton

MAPK signaling pathway

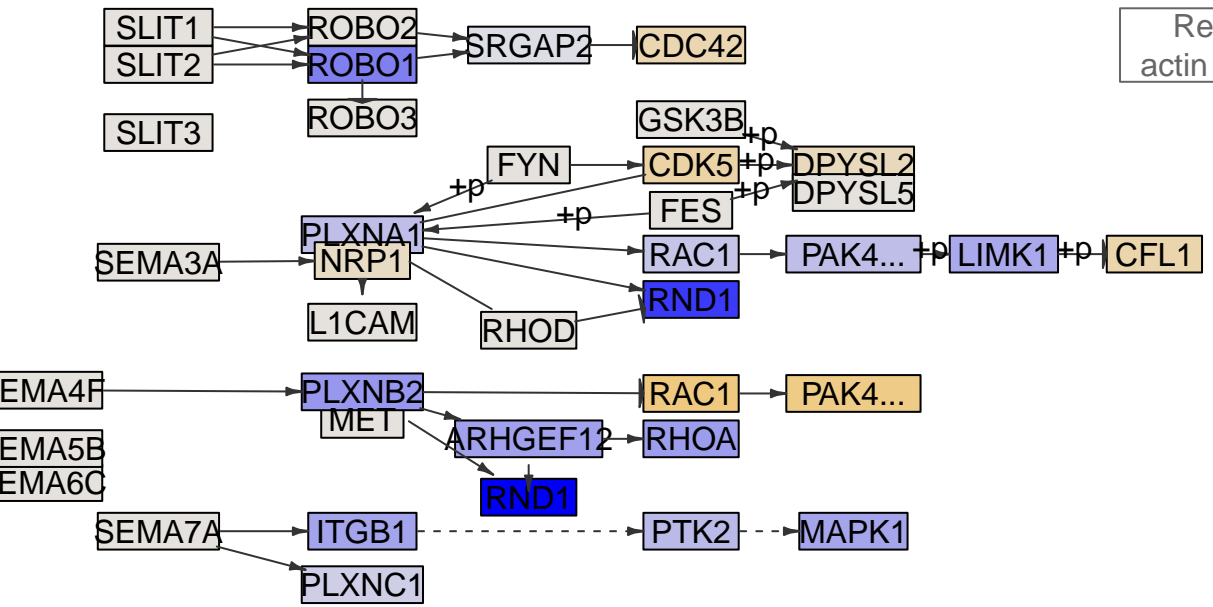

Regulation of actin cytoskeleton

Regulation of actin cytoskeleton

Axon guidance
MPI-114

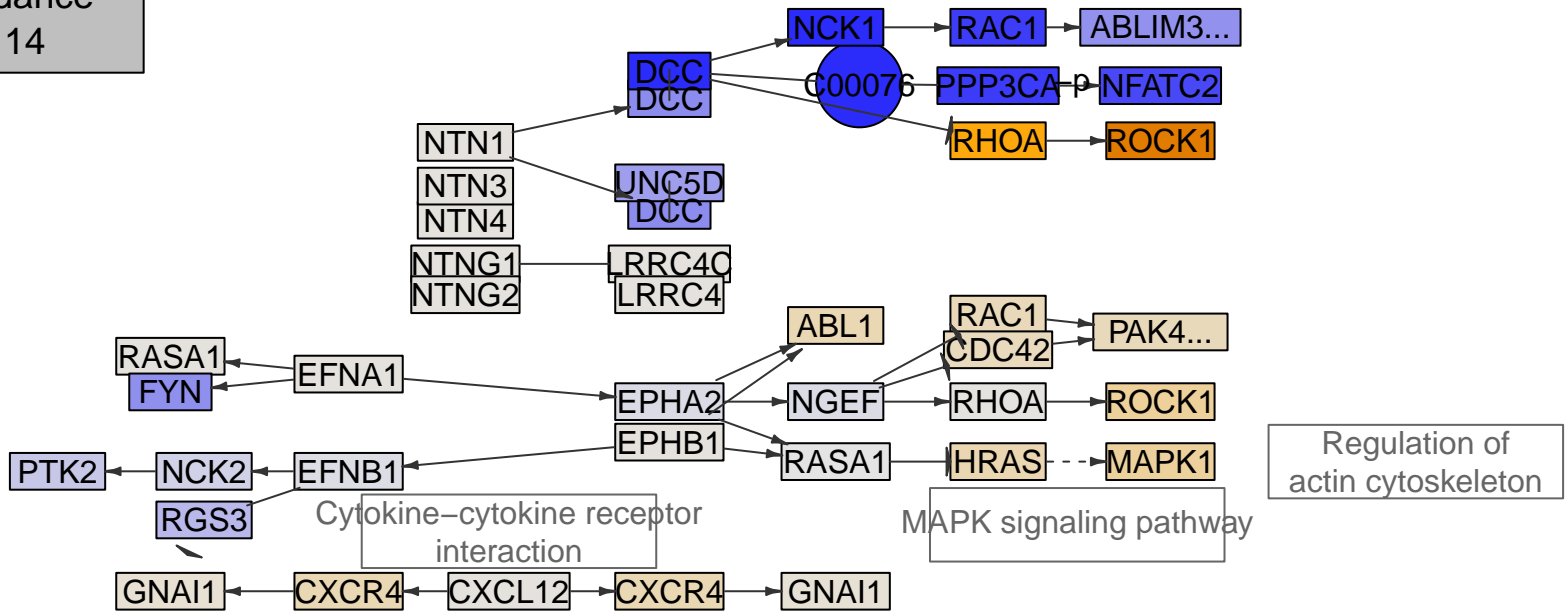

Regulation of actin cytoskeleton

MAPK signaling pathway

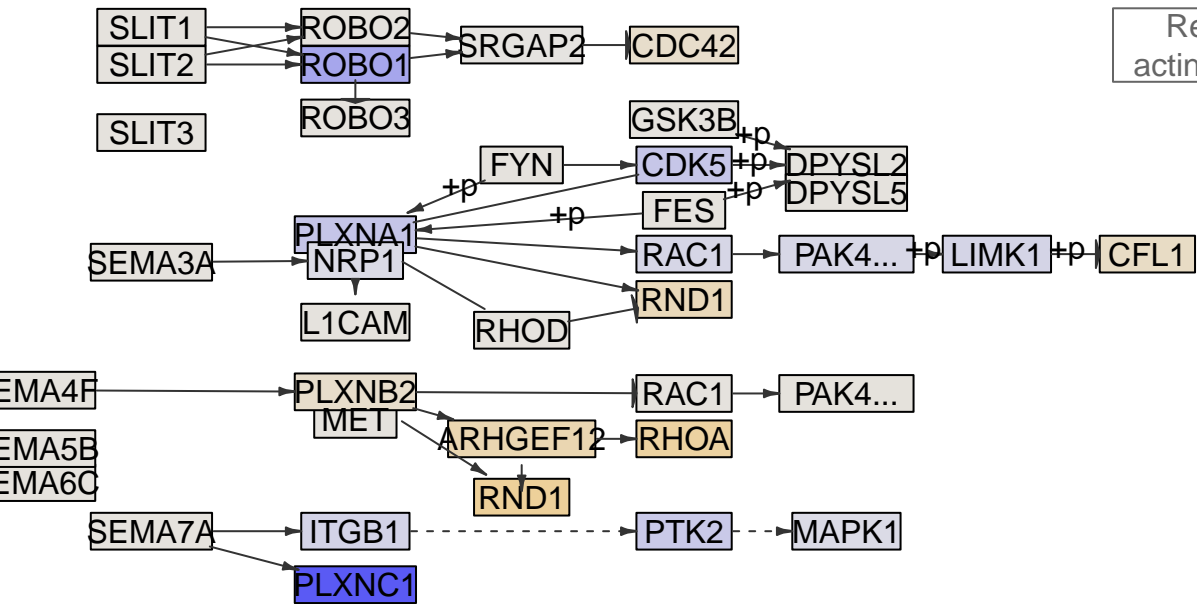

Regulation of actin cytoskeleton

Regulation of actin cytoskeleton

Axon guidance
MPI-123

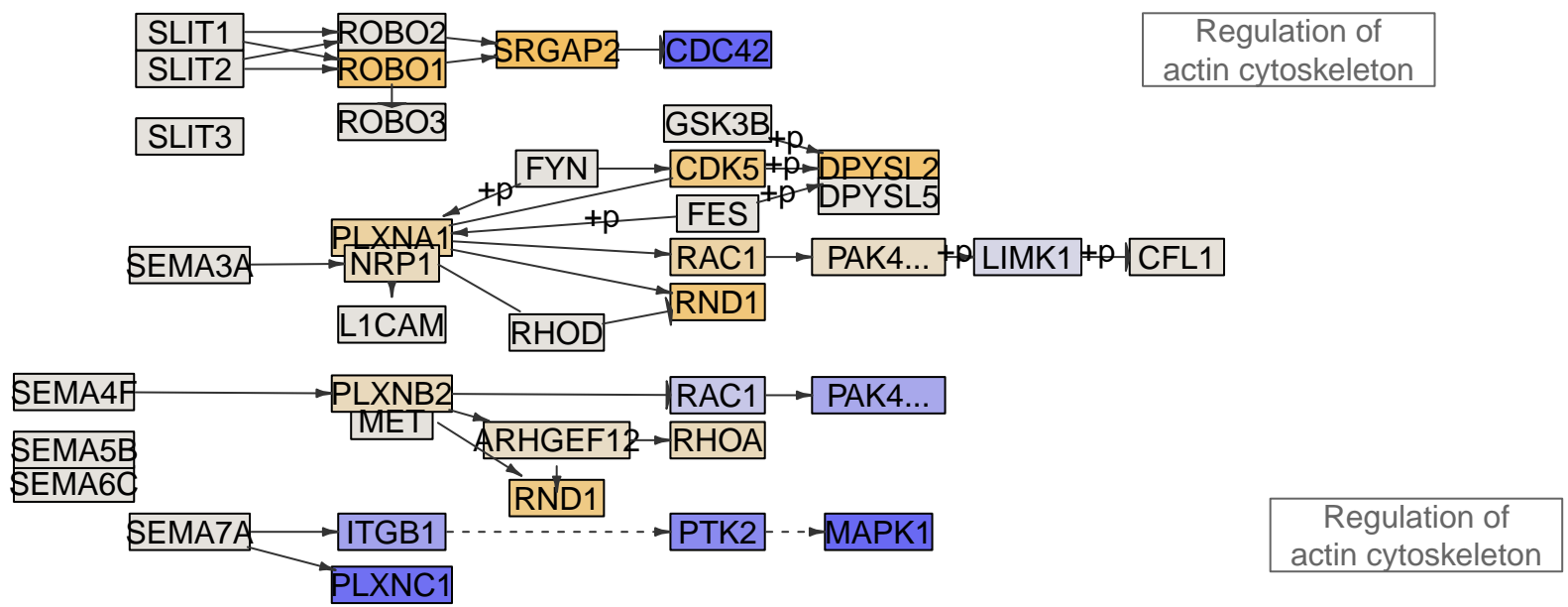
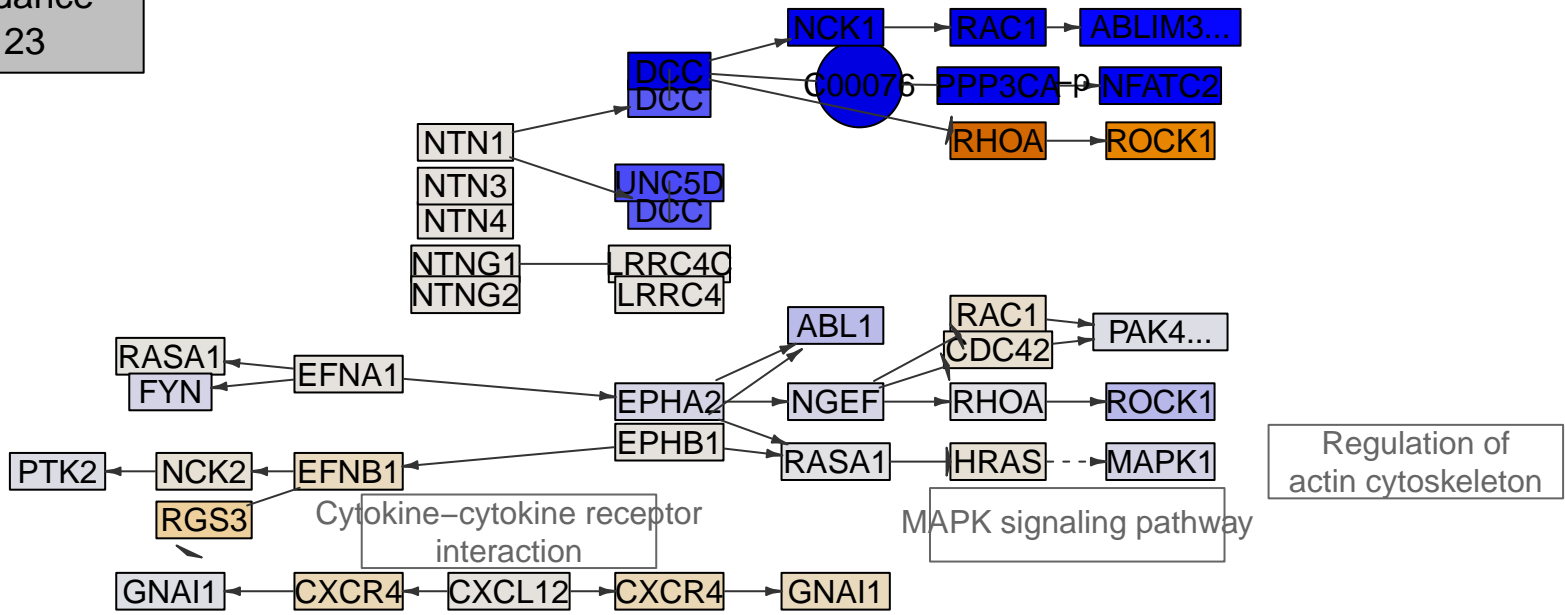

Axon guidance
MPI-138

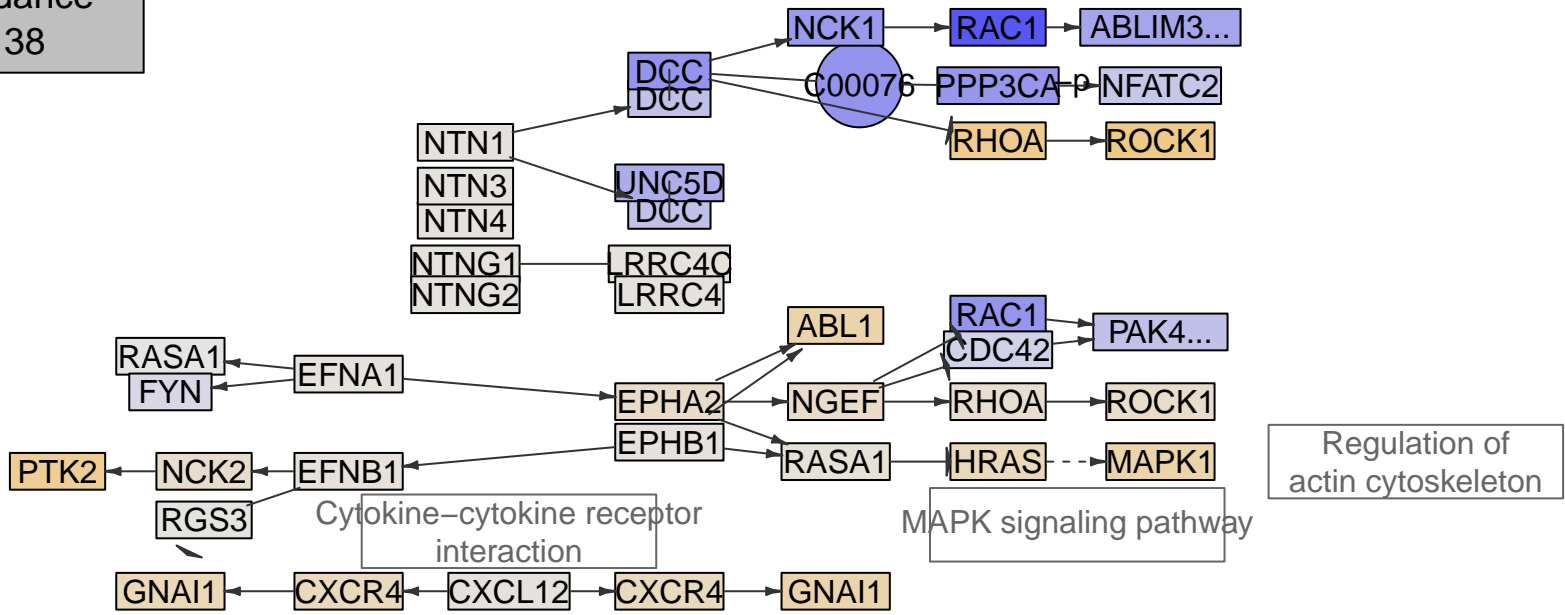

Regulation of actin cytoskeleton

MAPK signaling pathway

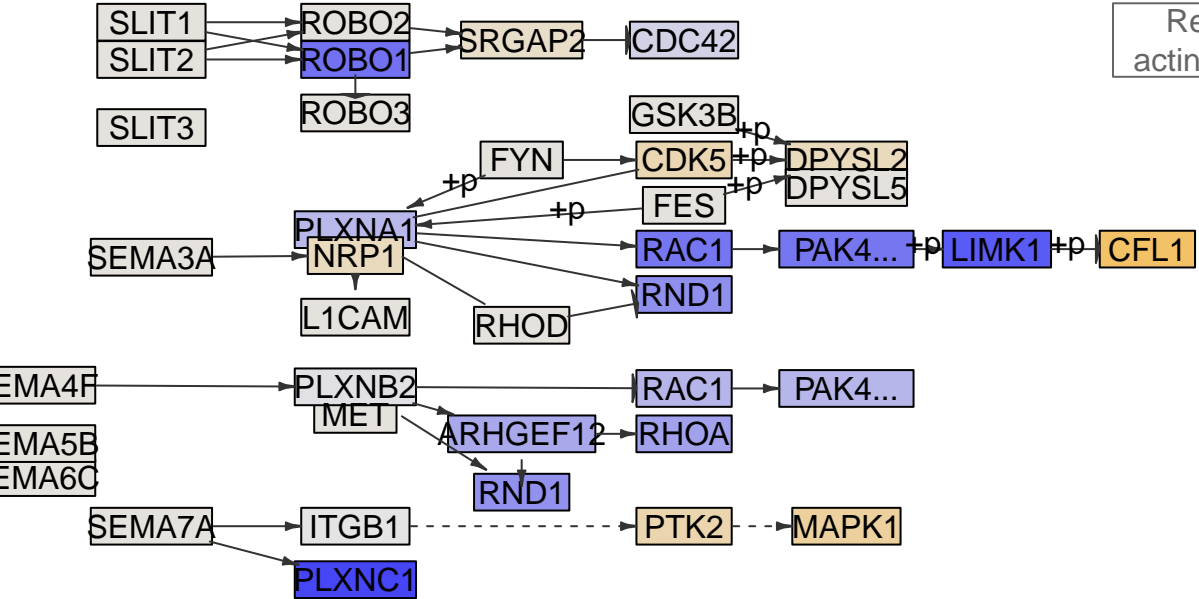

Regulation of actin cytoskeleton

Regulation of actin cytoskeleton

Axon guidance
MPI-139

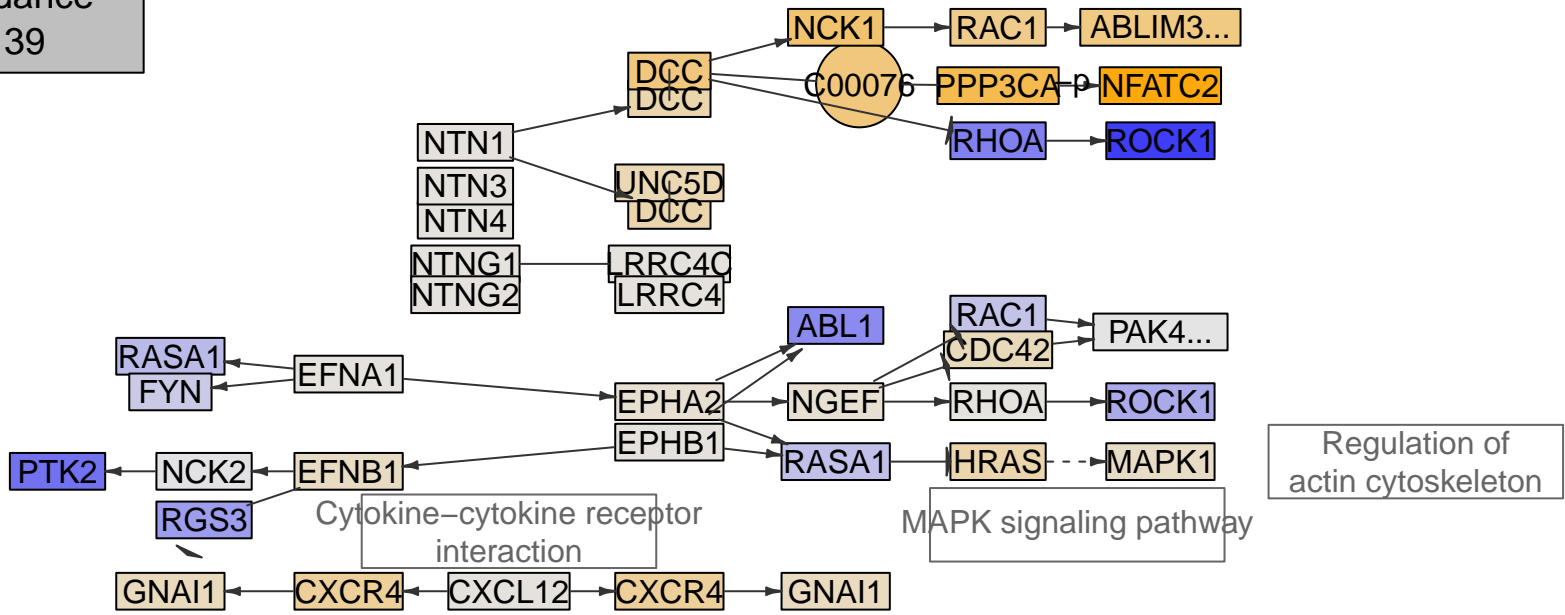

Regulation of actin cytoskeleton

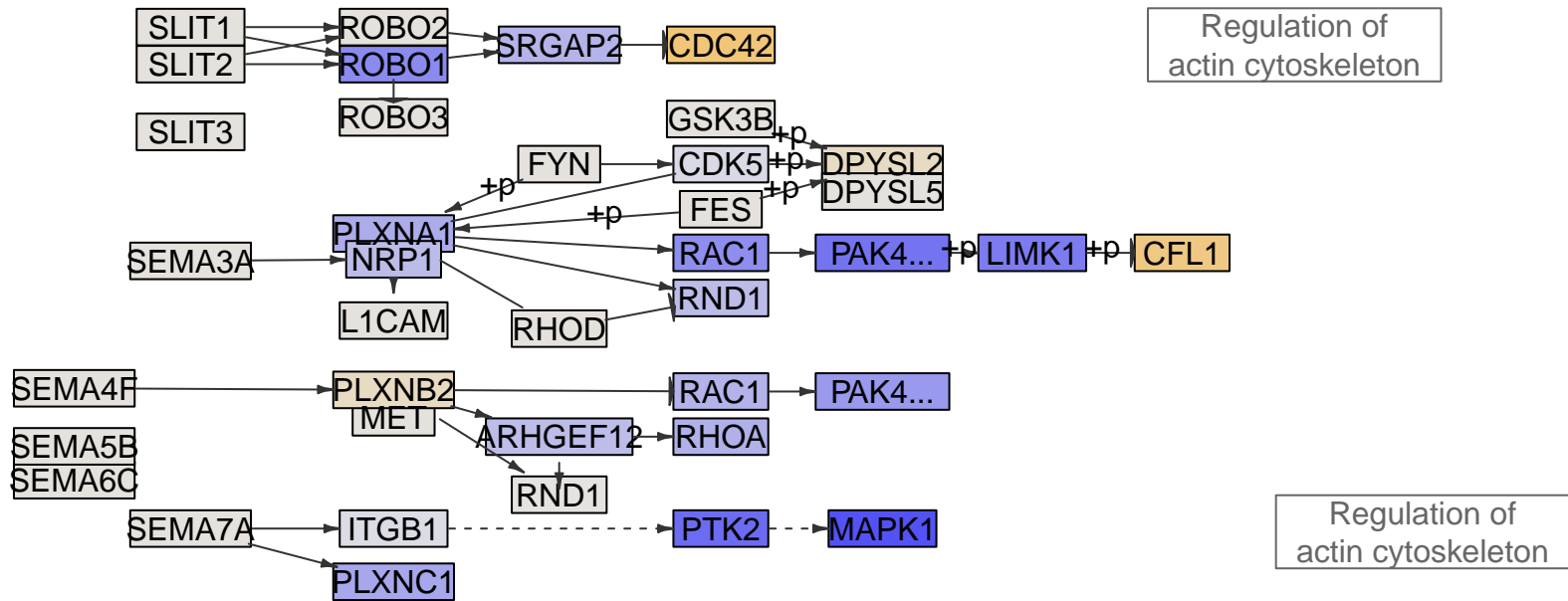

Regulation of actin cytoskeleton

Regulation of actin cytoskeleton

Axon guidance
MPI-140

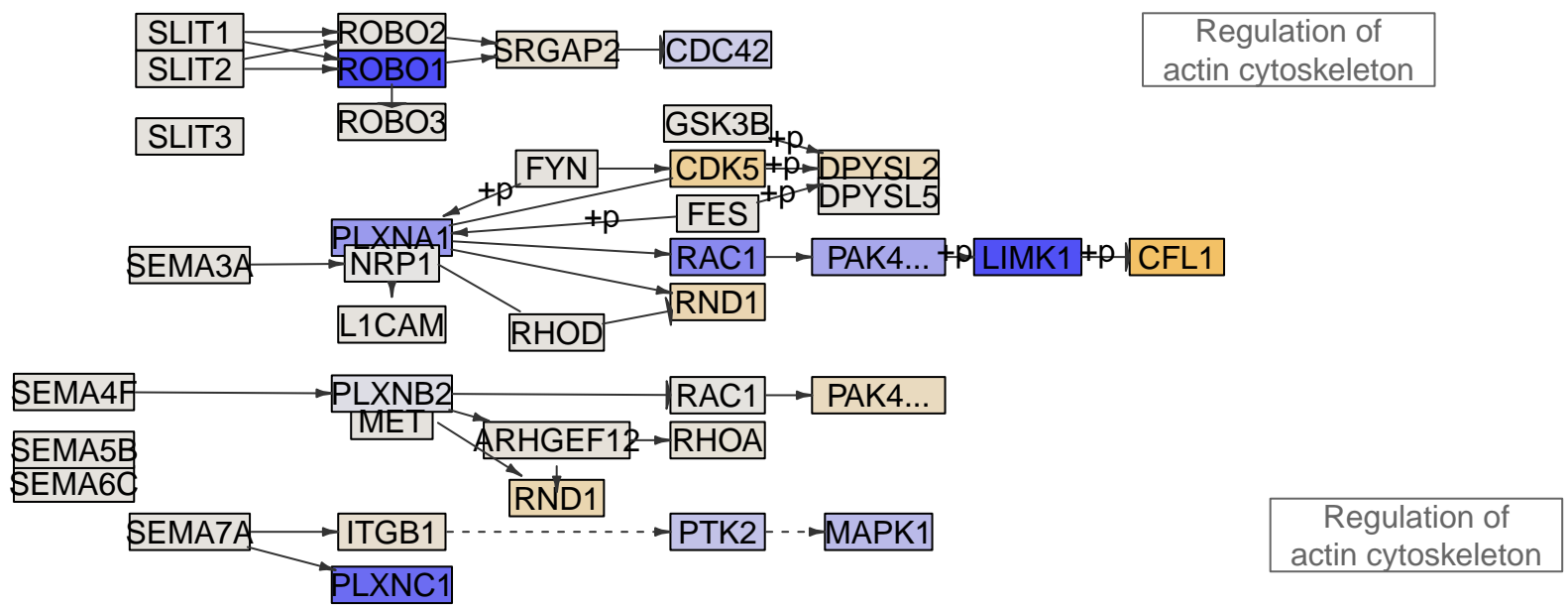
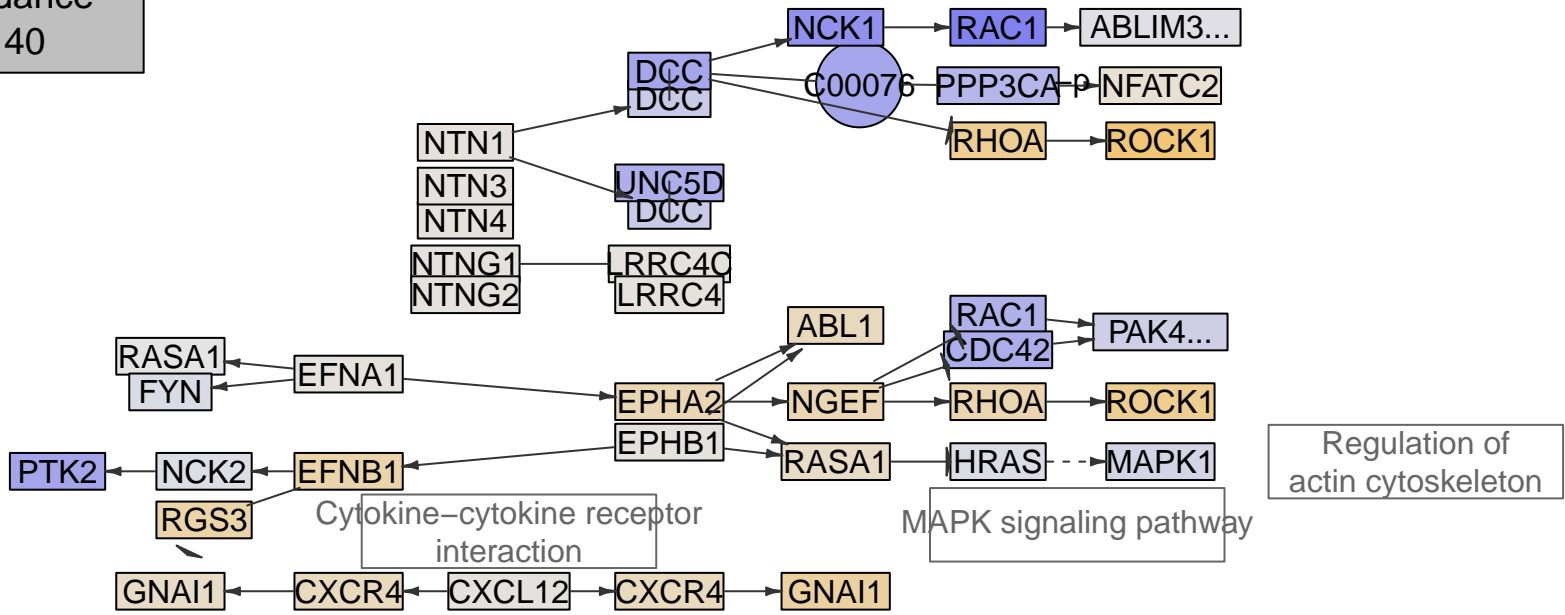

Axon guidance
MPI-144

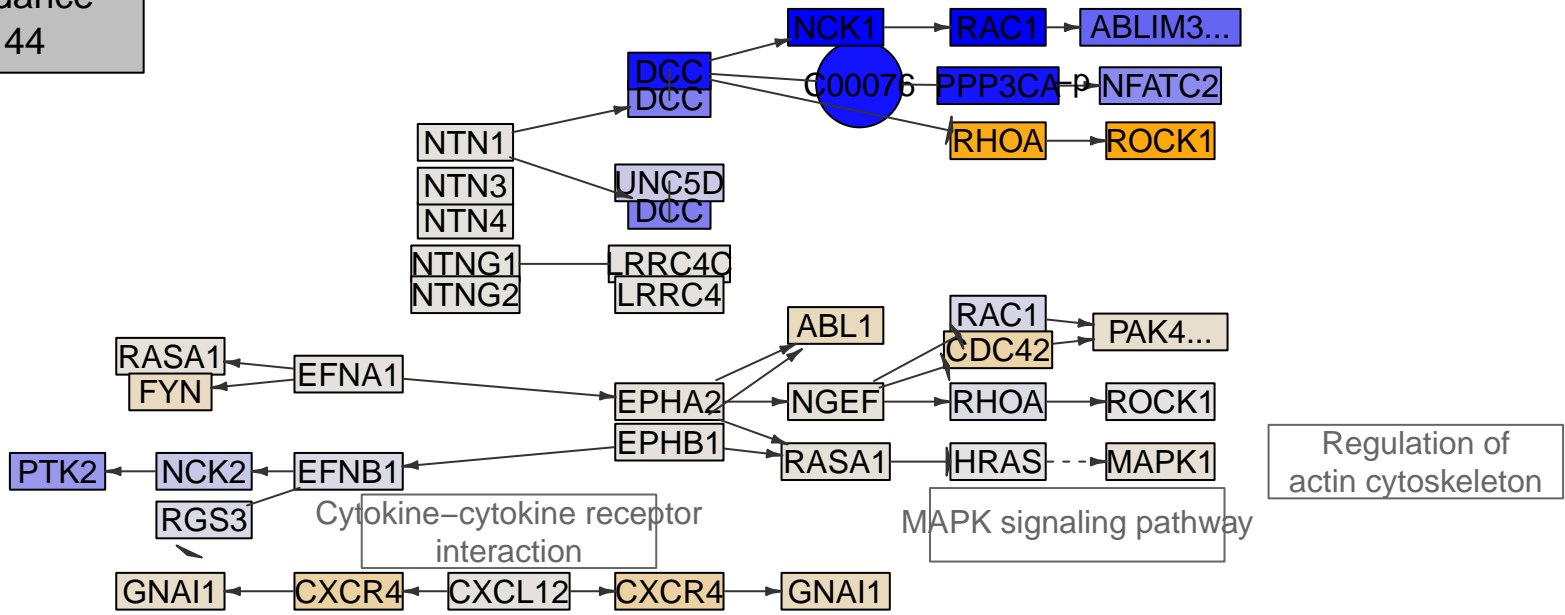

Regulation of actin cytoskeleton

MAPK signaling pathway

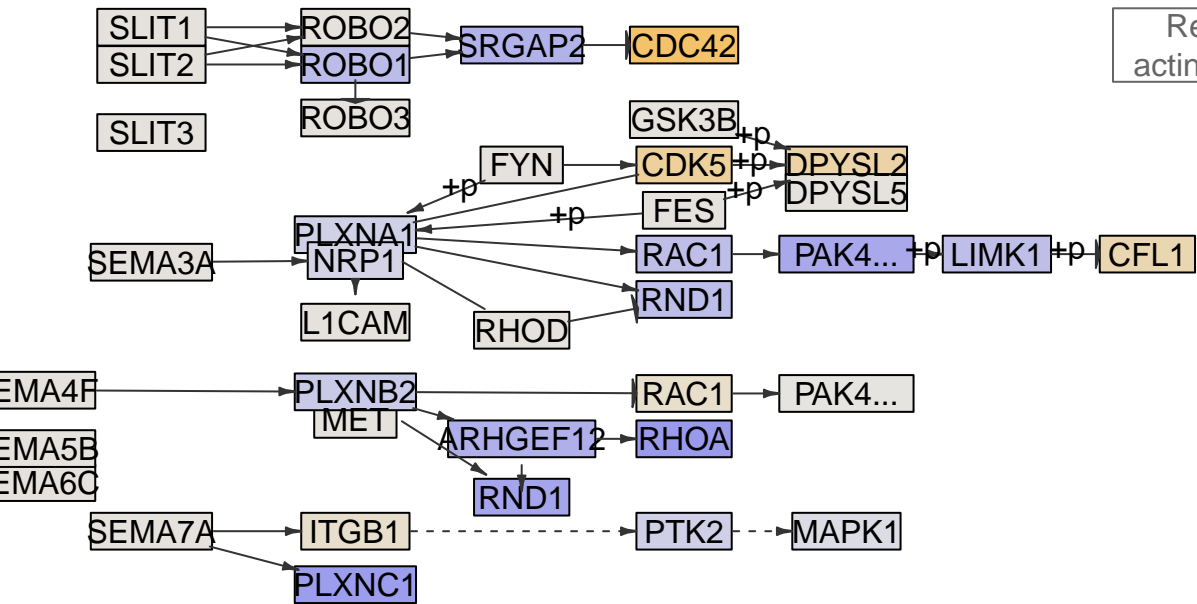

Regulation of actin cytoskeleton

Regulation of actin cytoskeleton

Axon guidance
MPI-147

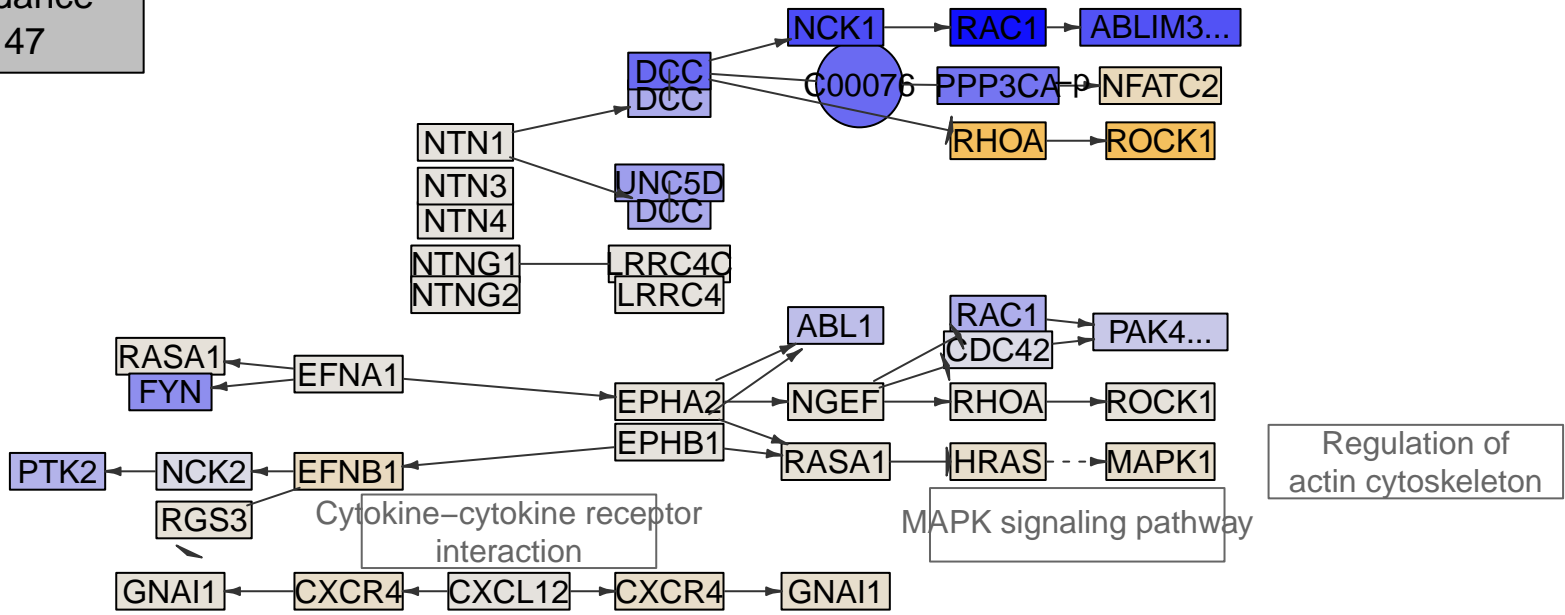

Regulation of actin cytoskeleton

MAPK signaling pathway

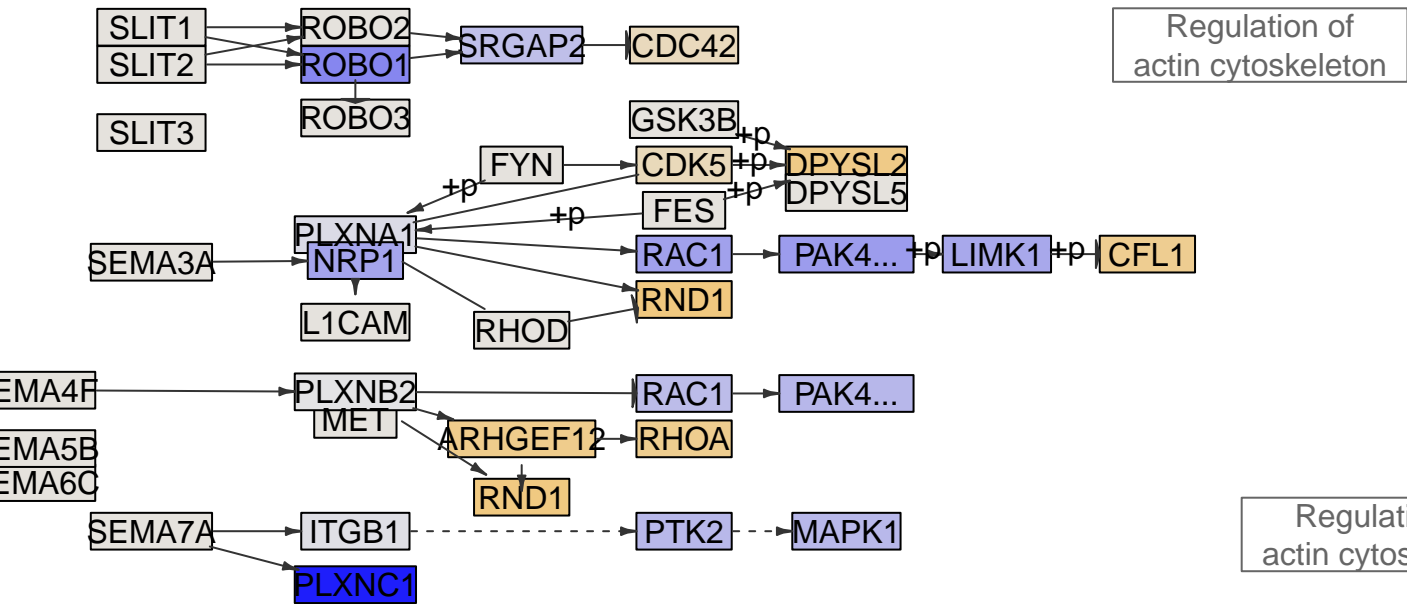

Regulation of actin cytoskeleton

Regulation of actin cytoskeleton

Axon guidance
MPI-171

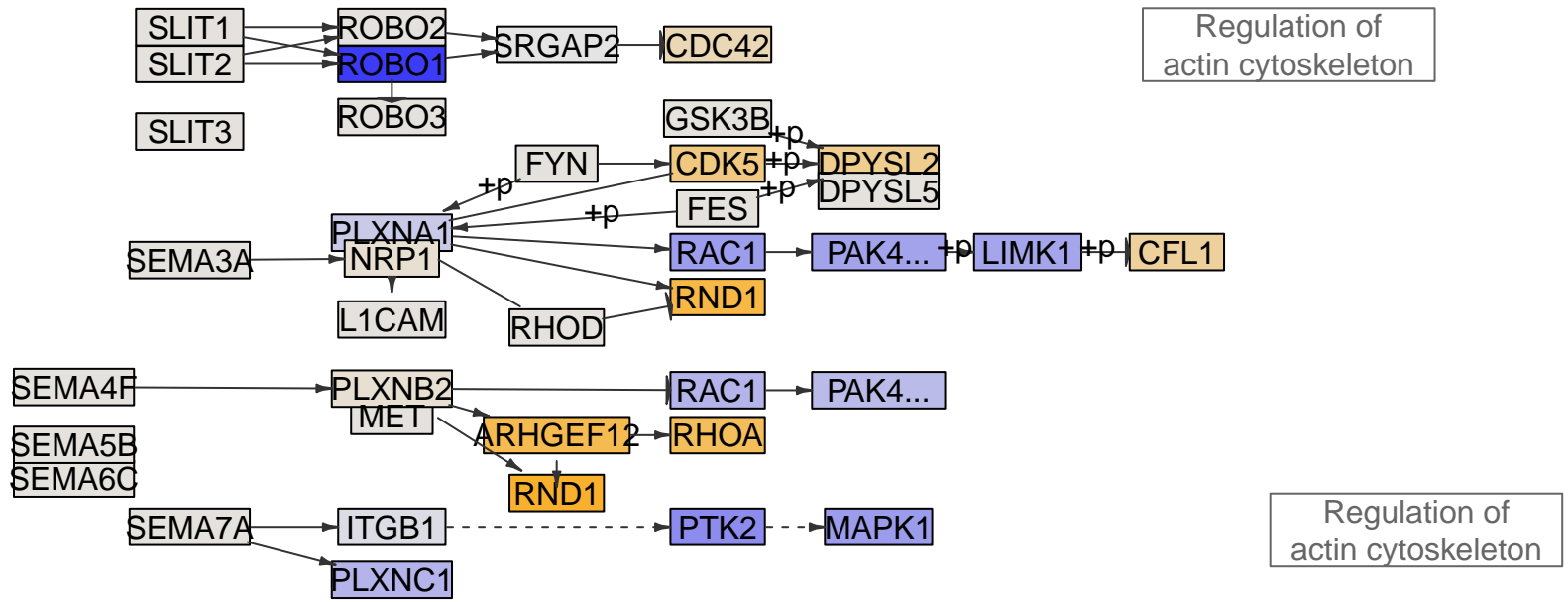
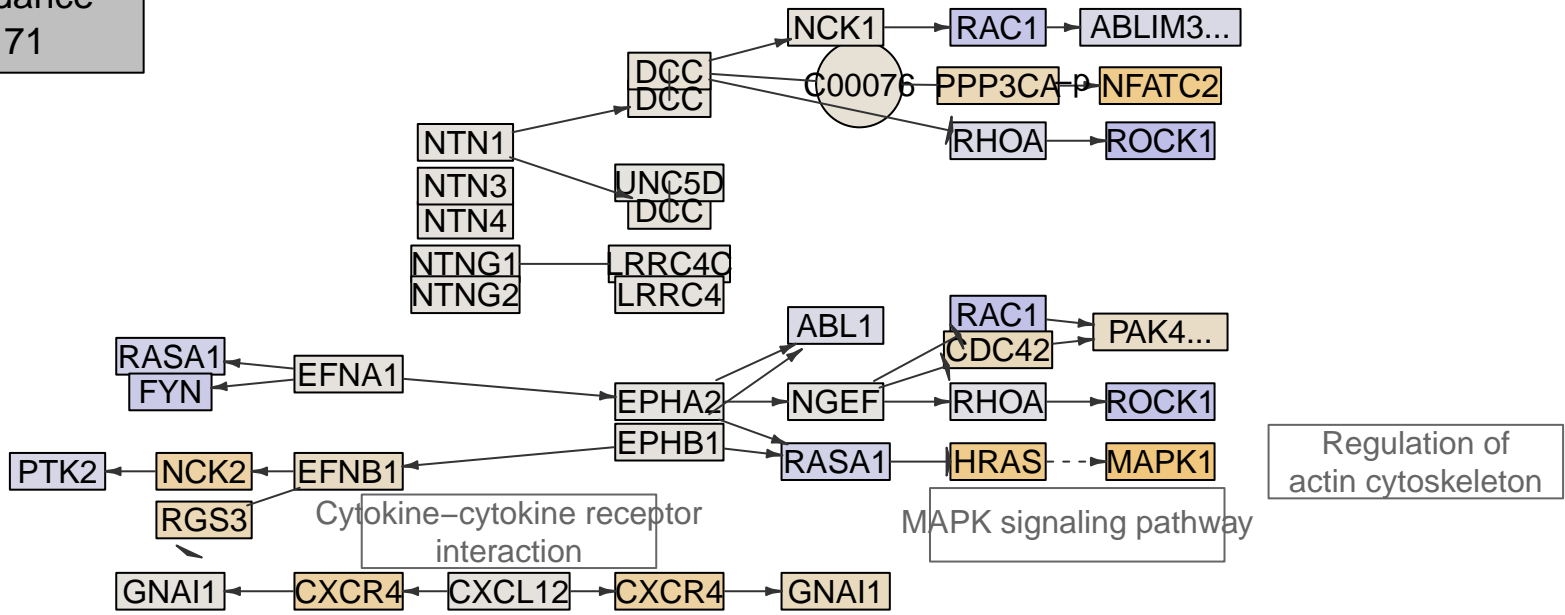

Axon guidance
MPI-172

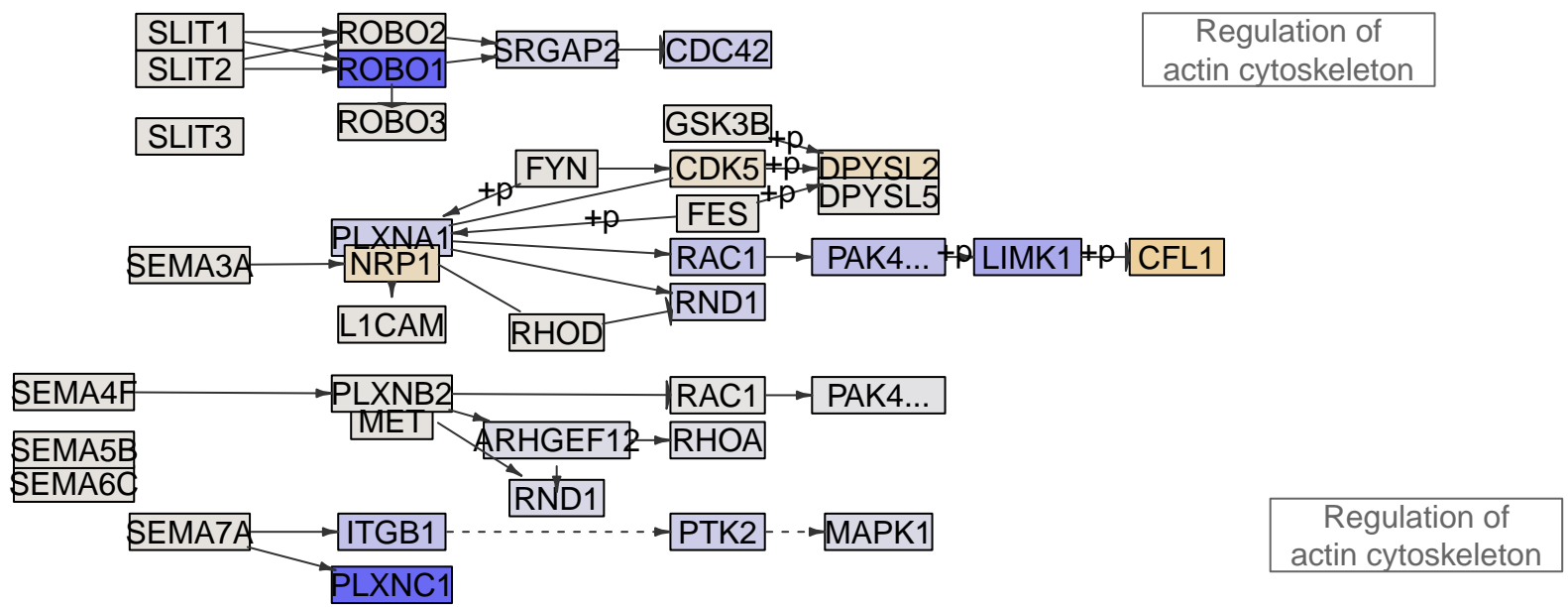
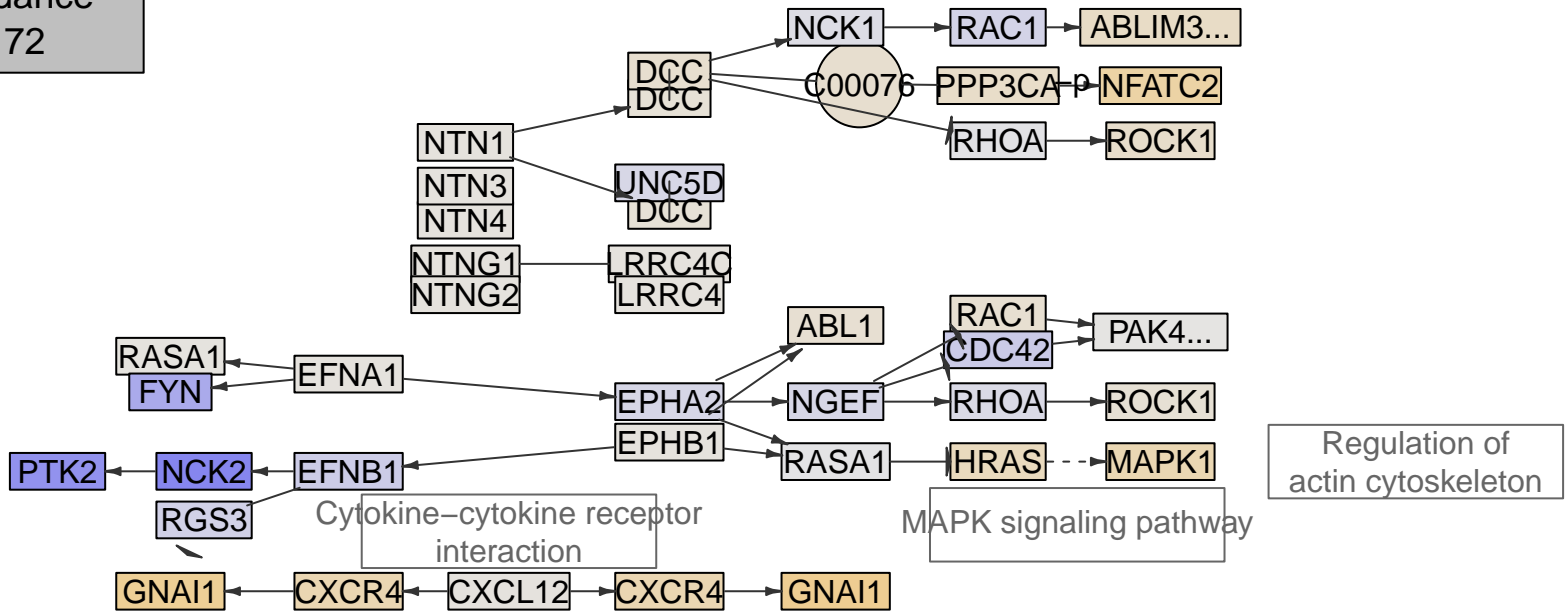

Axon guidance
MPI-007

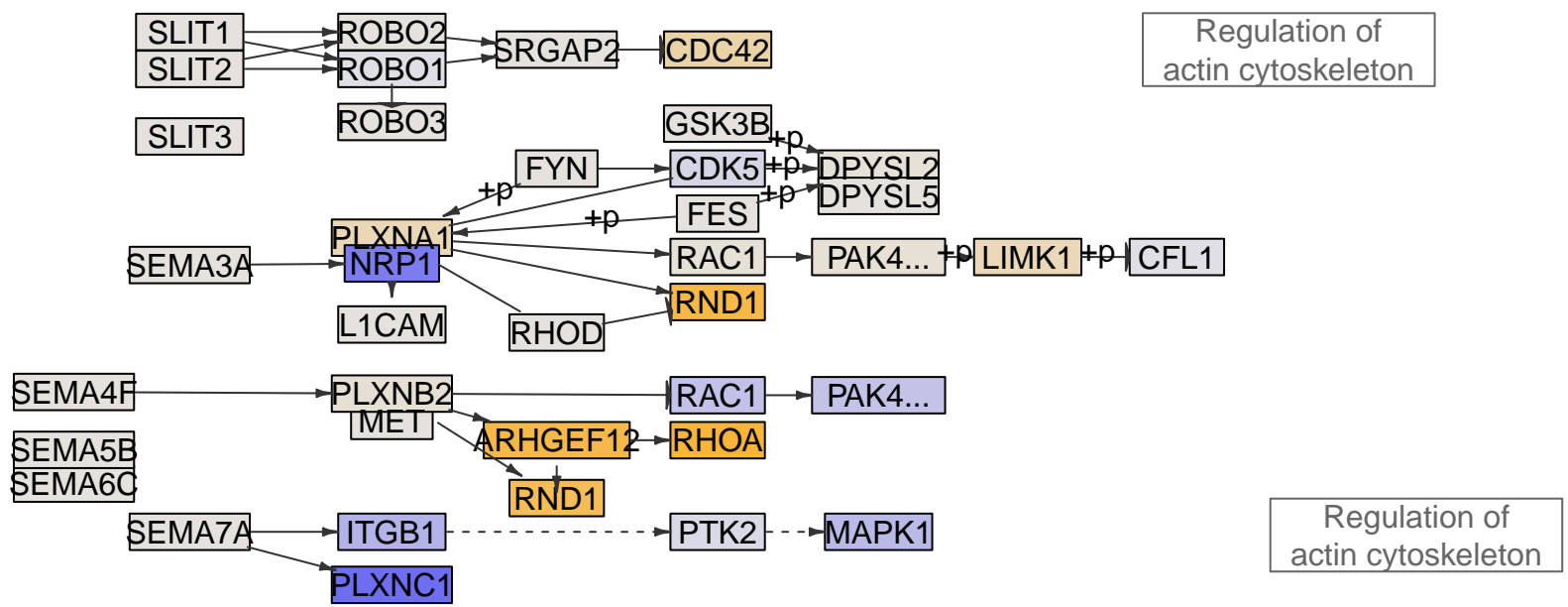
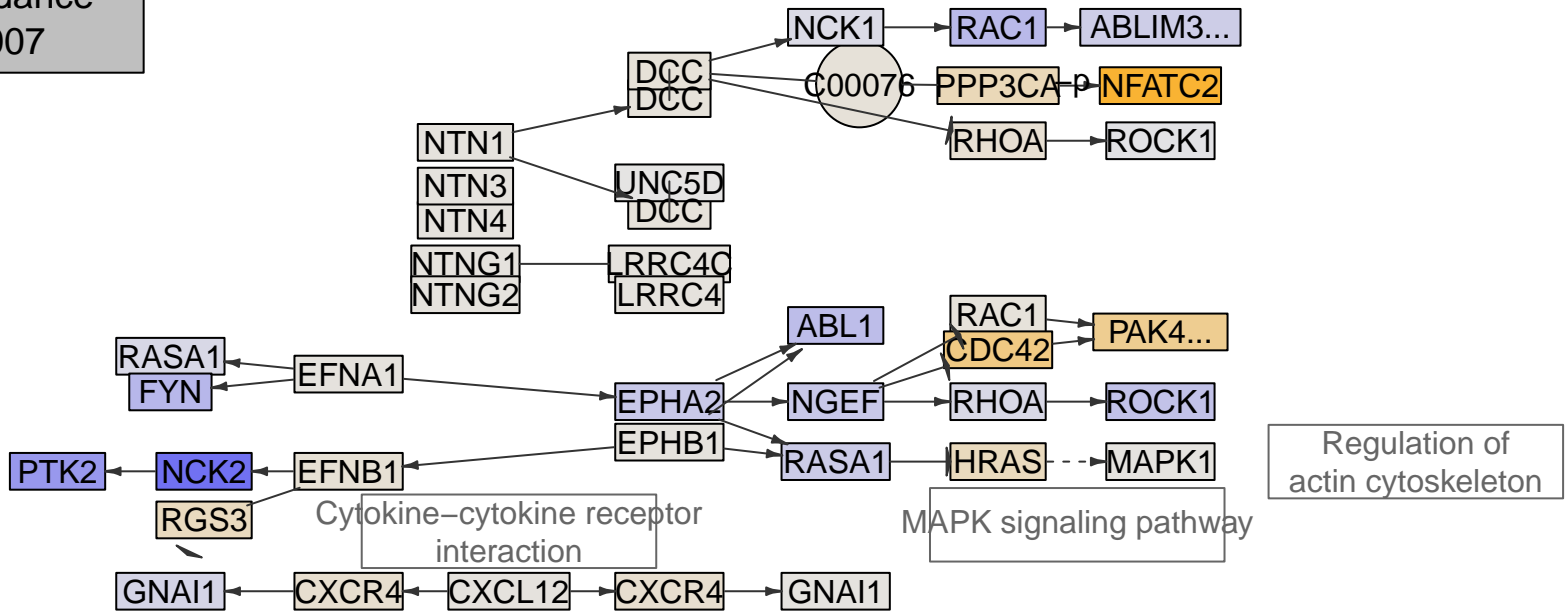

Axon guidance
MPI-011

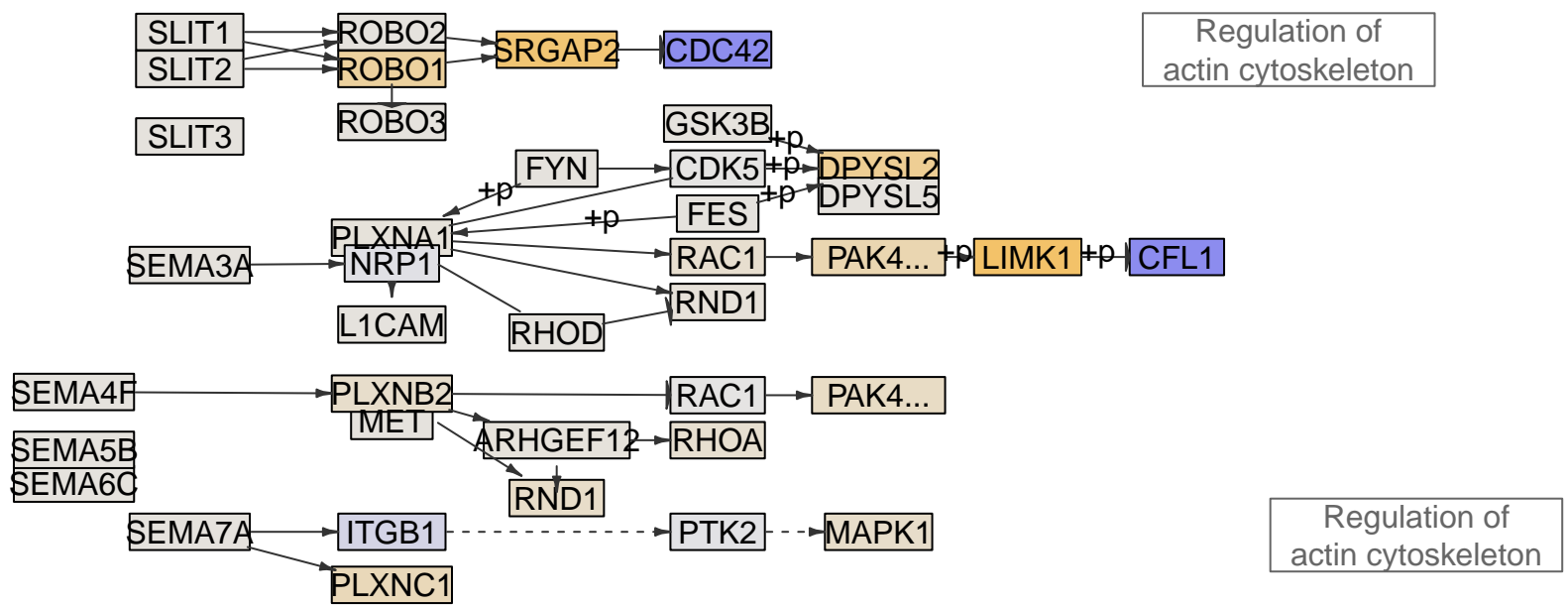
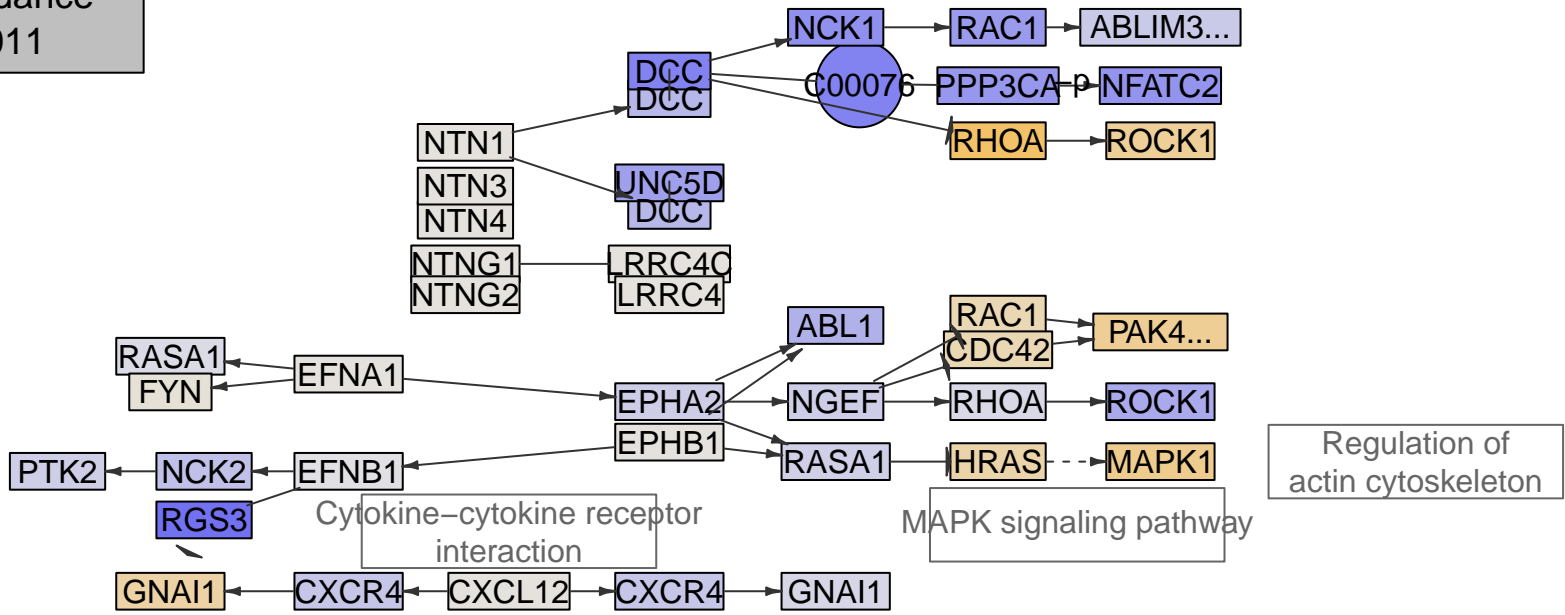

Axon guidance
MPI-024

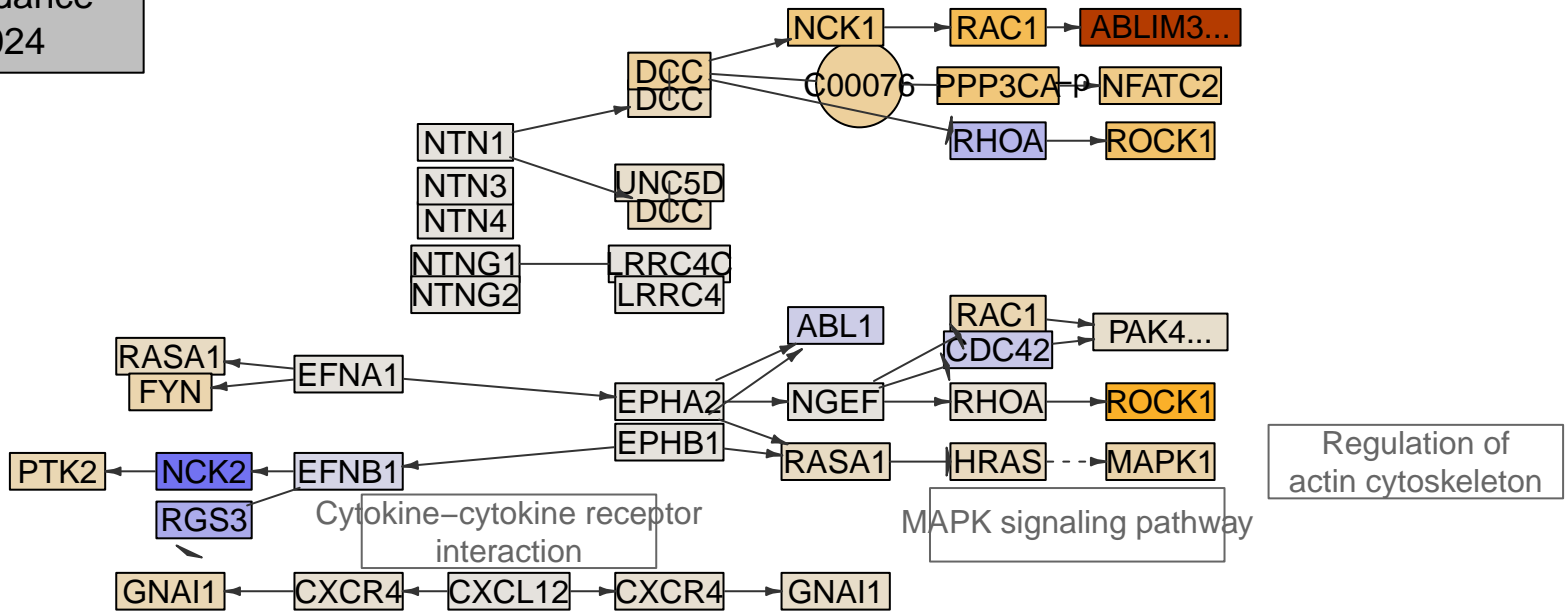

Regulation of actin cytoskeleton

MAPK signaling pathway

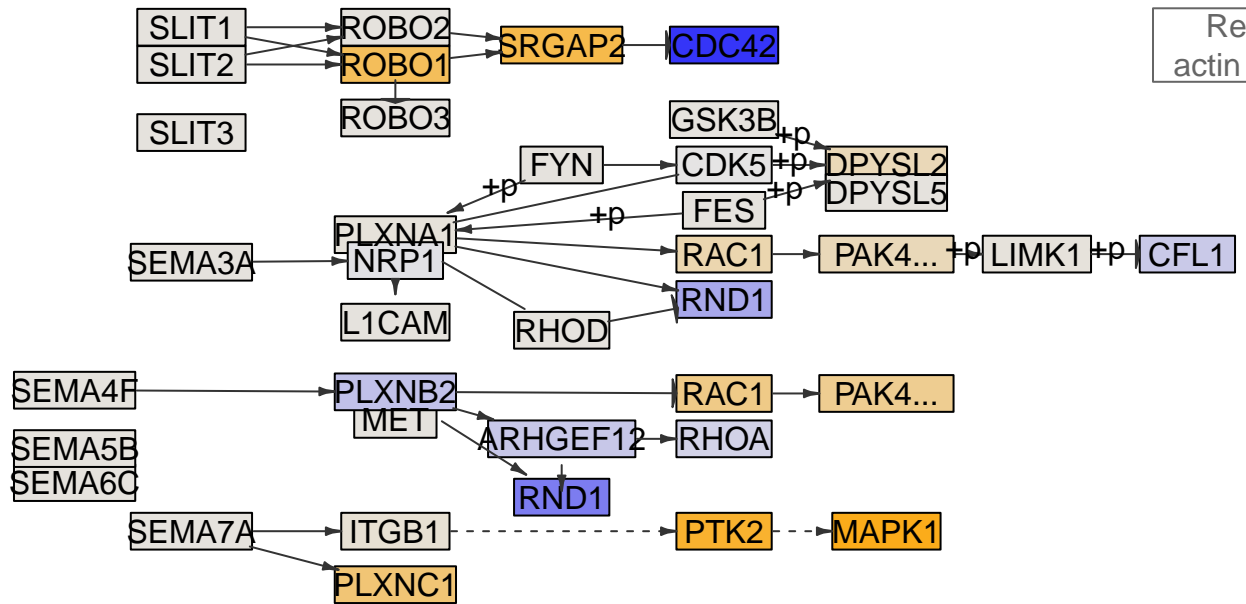

Regulation of actin cytoskeleton

Regulation of actin cytoskeleton

Axon guidance
MPI-026

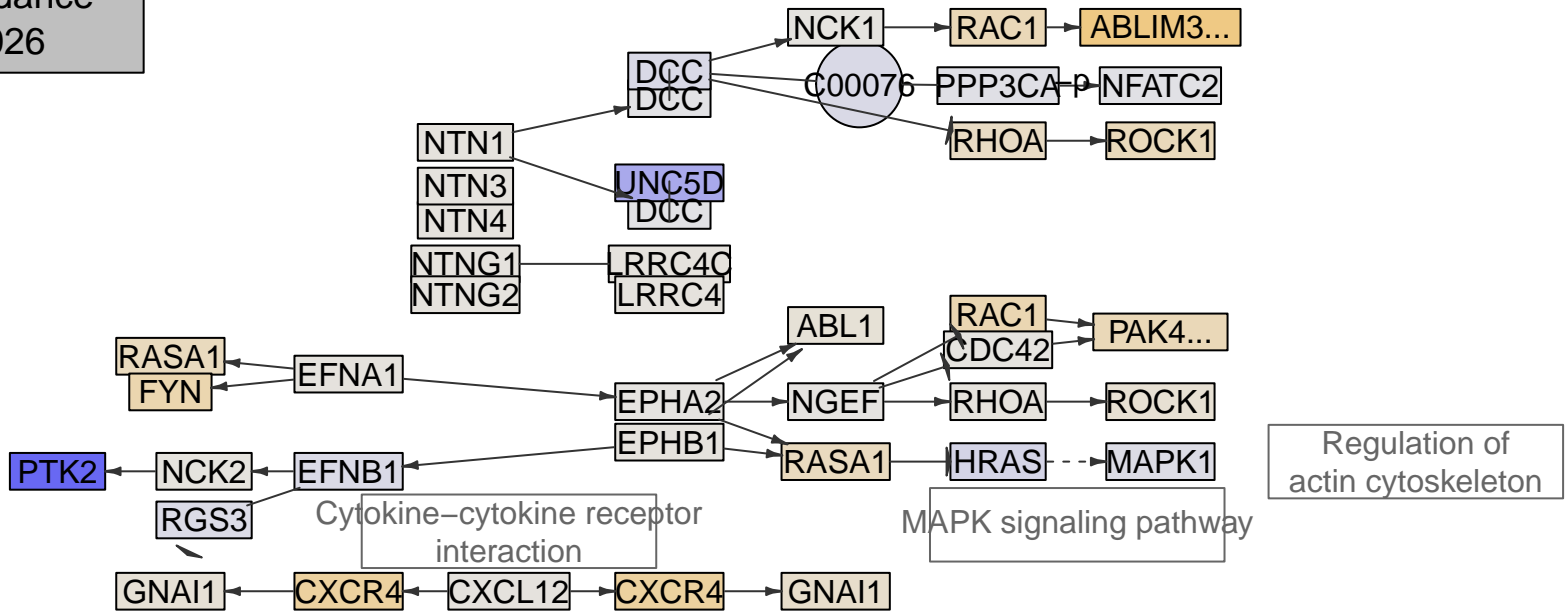

Regulation of actin cytoskeleton

MAPK signaling pathway

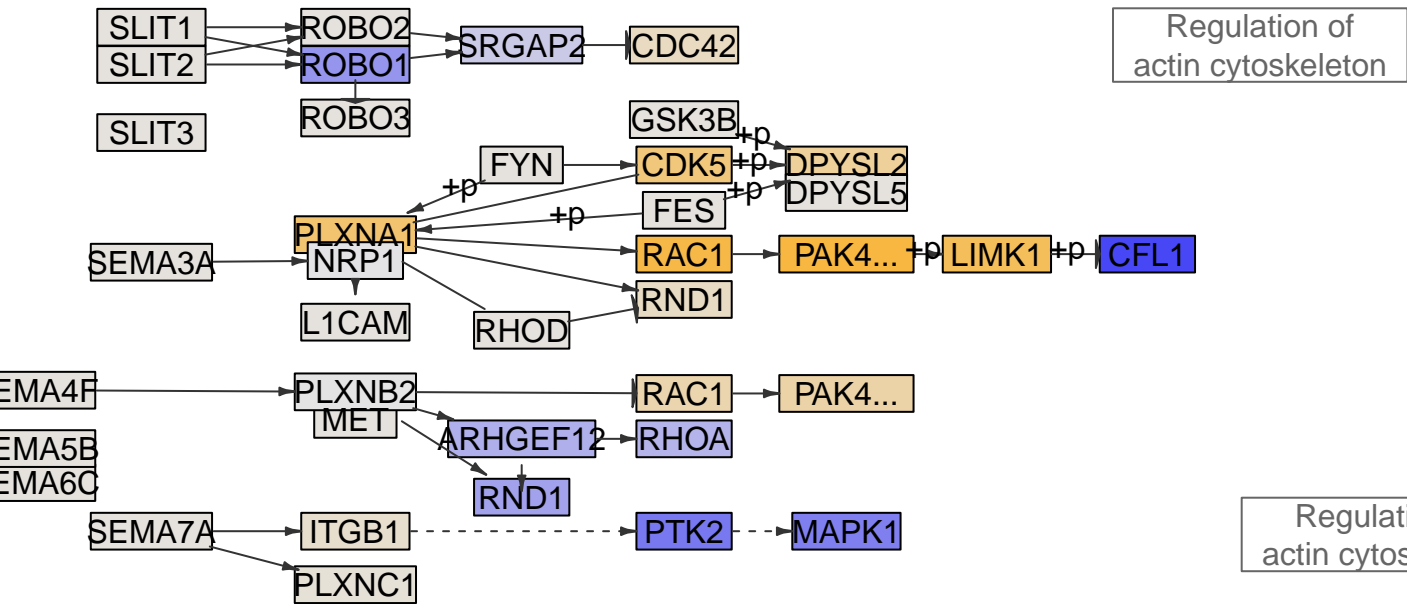

Regulation of actin cytoskeleton

Regulation of actin cytoskeleton

Axon guidance
MPI-036

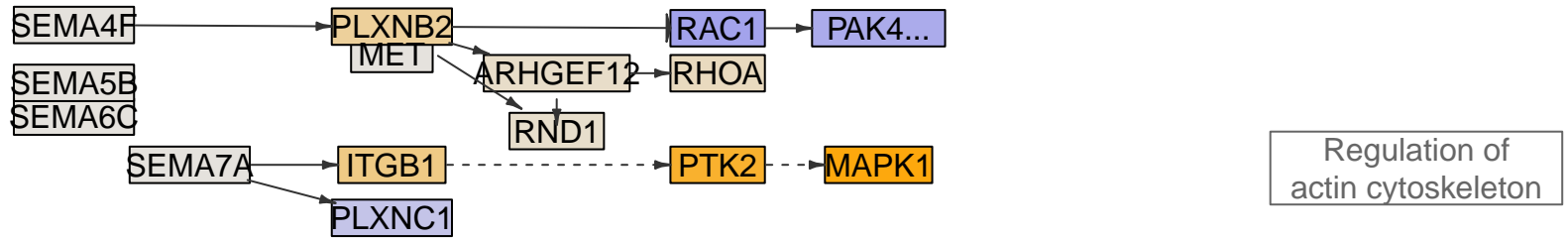
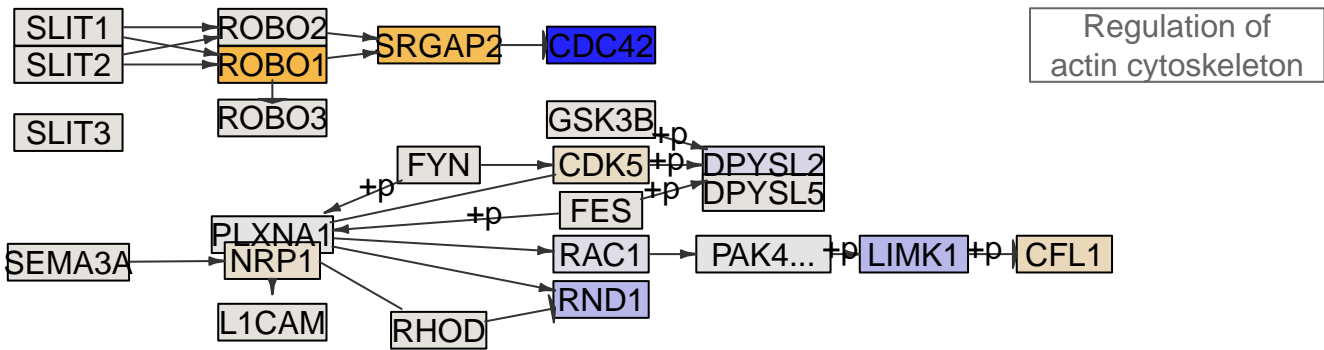
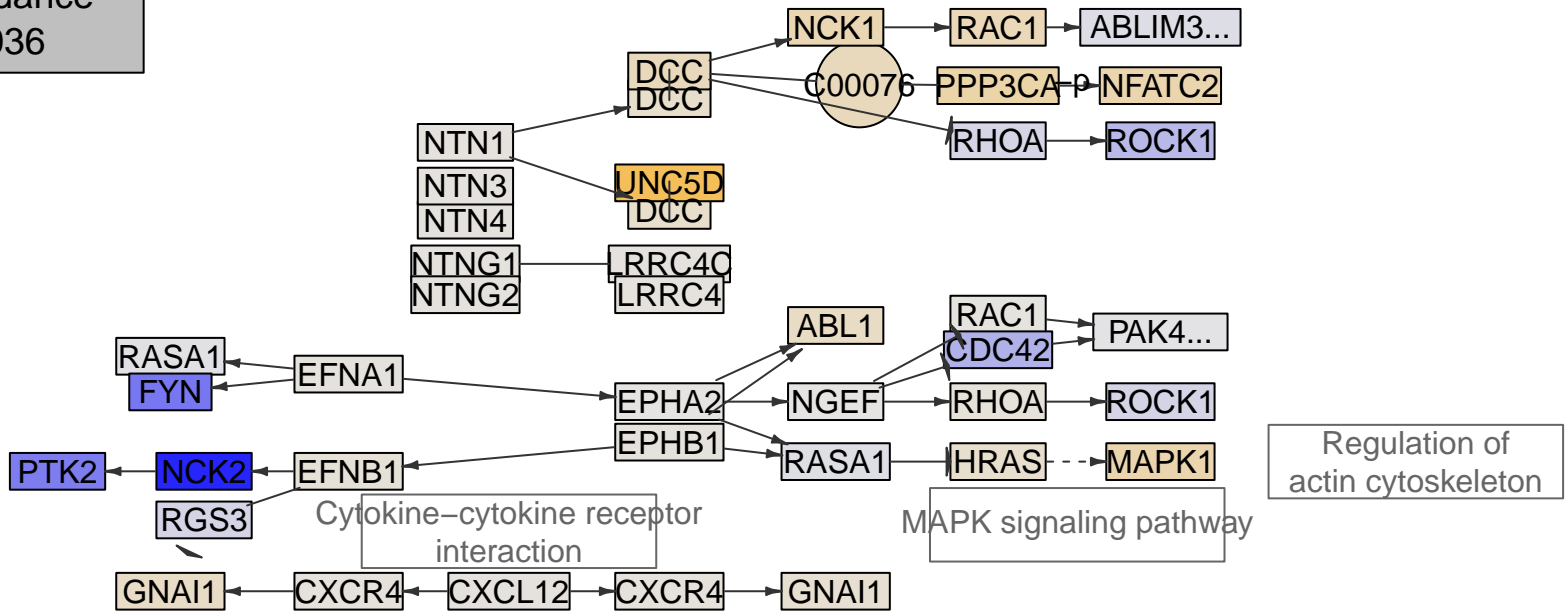

Axon guidance
MPI-037

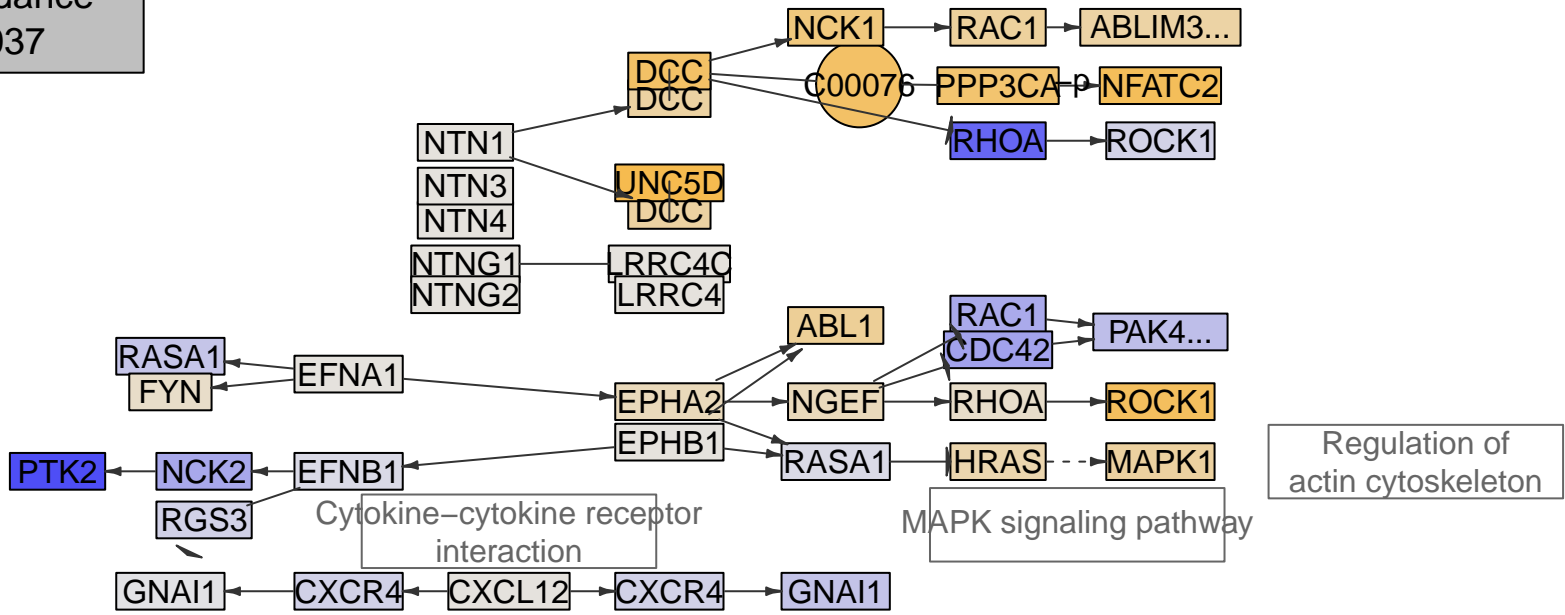

Regulation of actin cytoskeleton

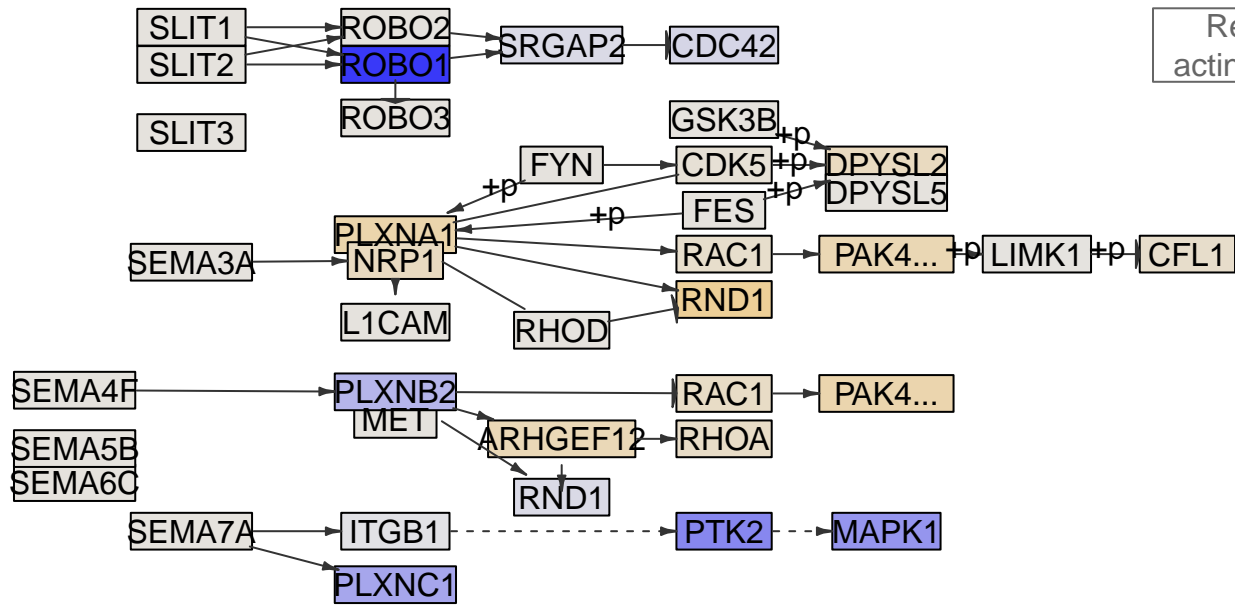

Regulation of actin cytoskeleton

Regulation of actin cytoskeleton

Axon guidance
MPI-038

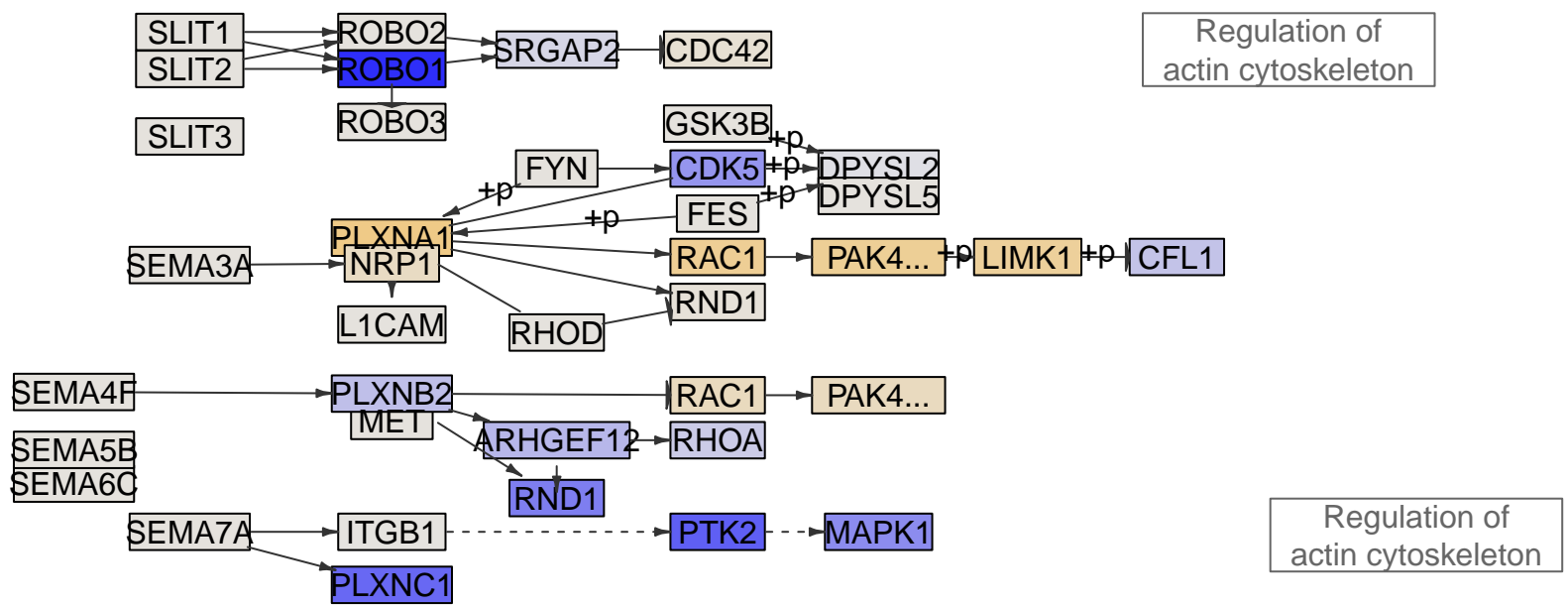
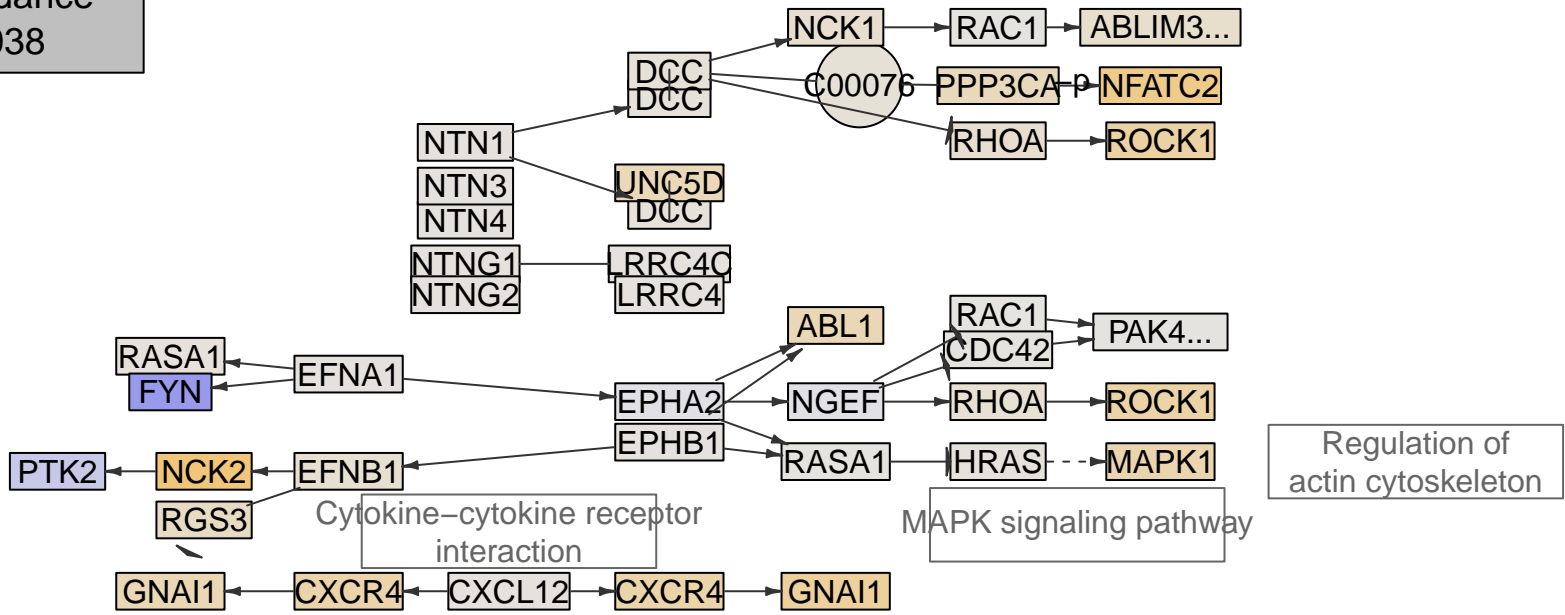

Axon guidance
MPI-041

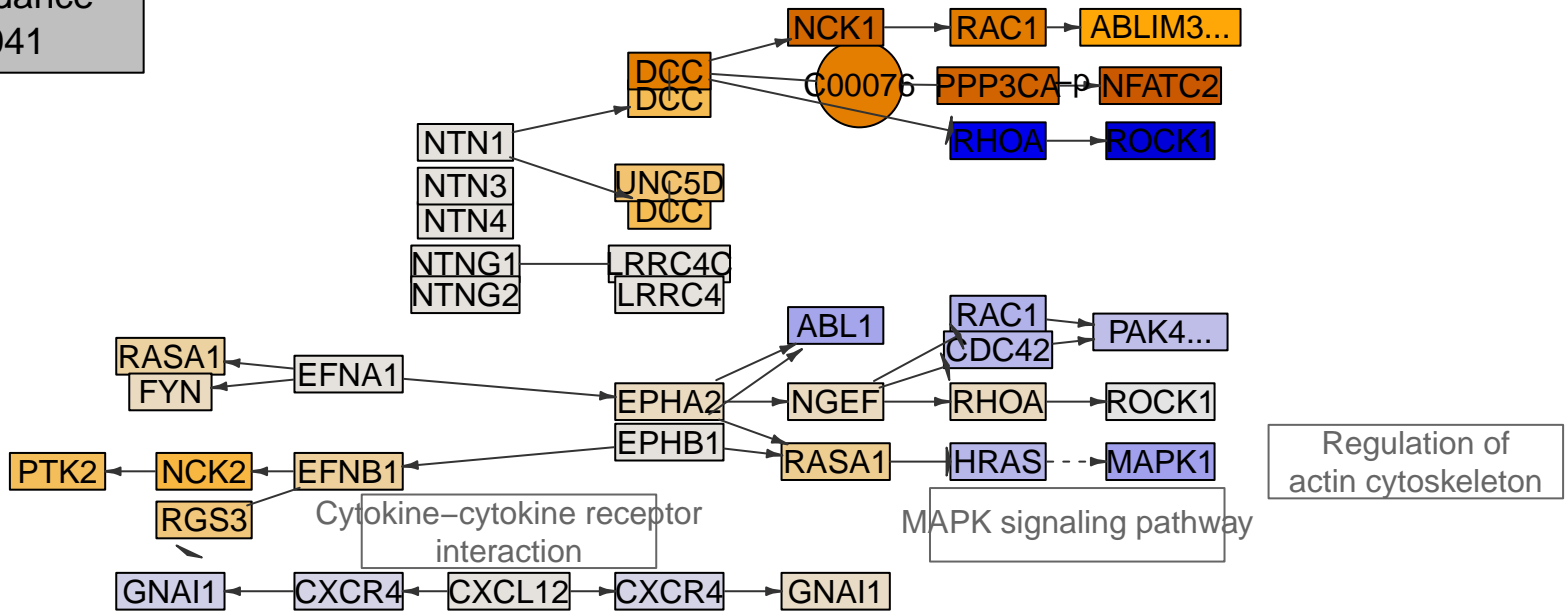

Regulation of actin cytoskeleton

MAPK signaling pathway

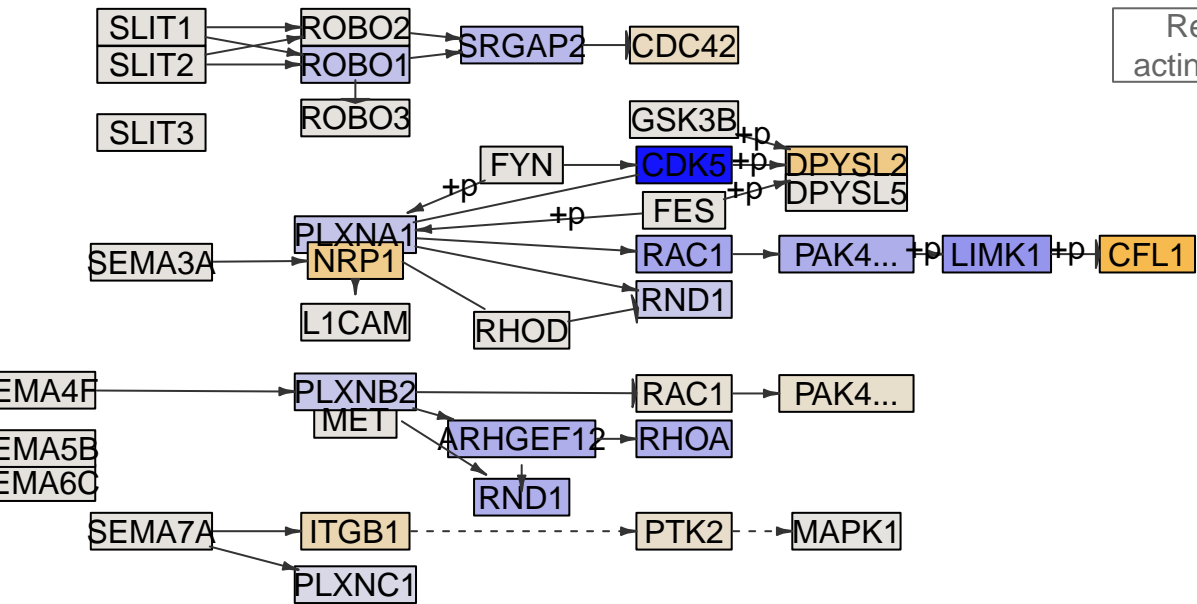

Regulation of actin cytoskeleton

Regulation of actin cytoskeleton

Axon guidance
MPI-046

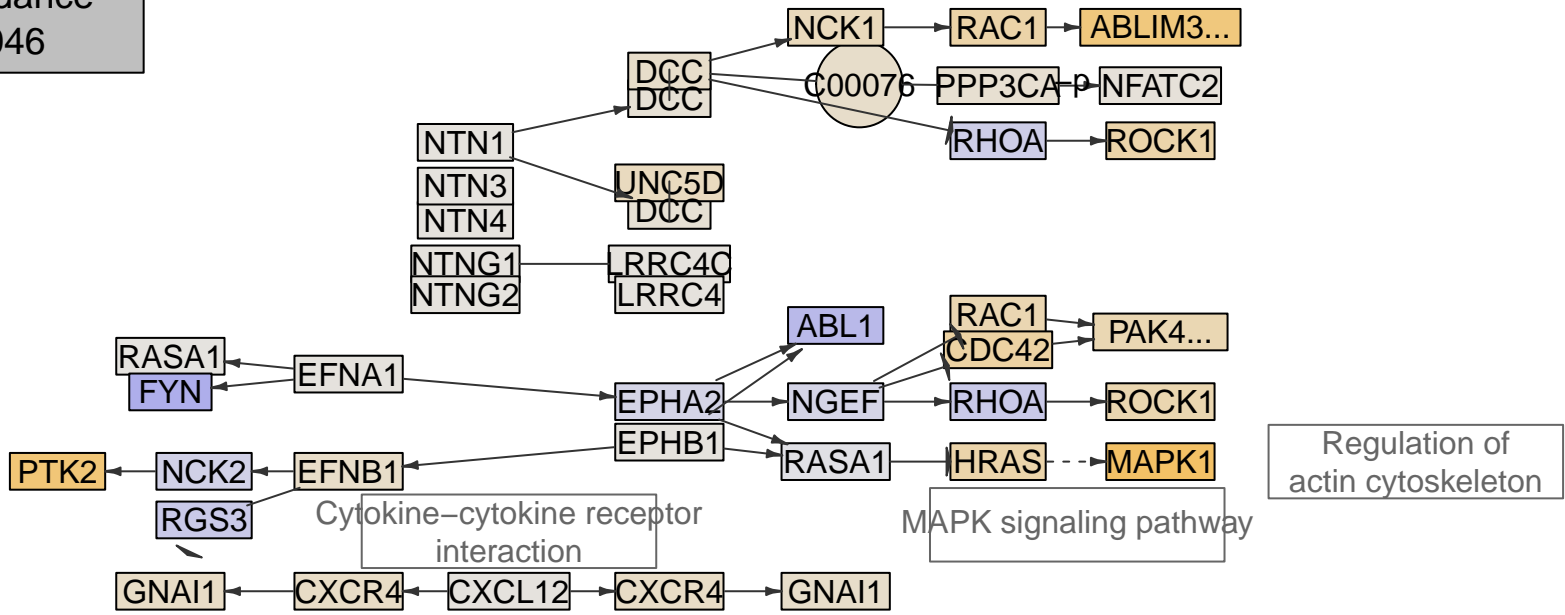

Regulation of actin cytoskeleton

MAPK signaling pathway

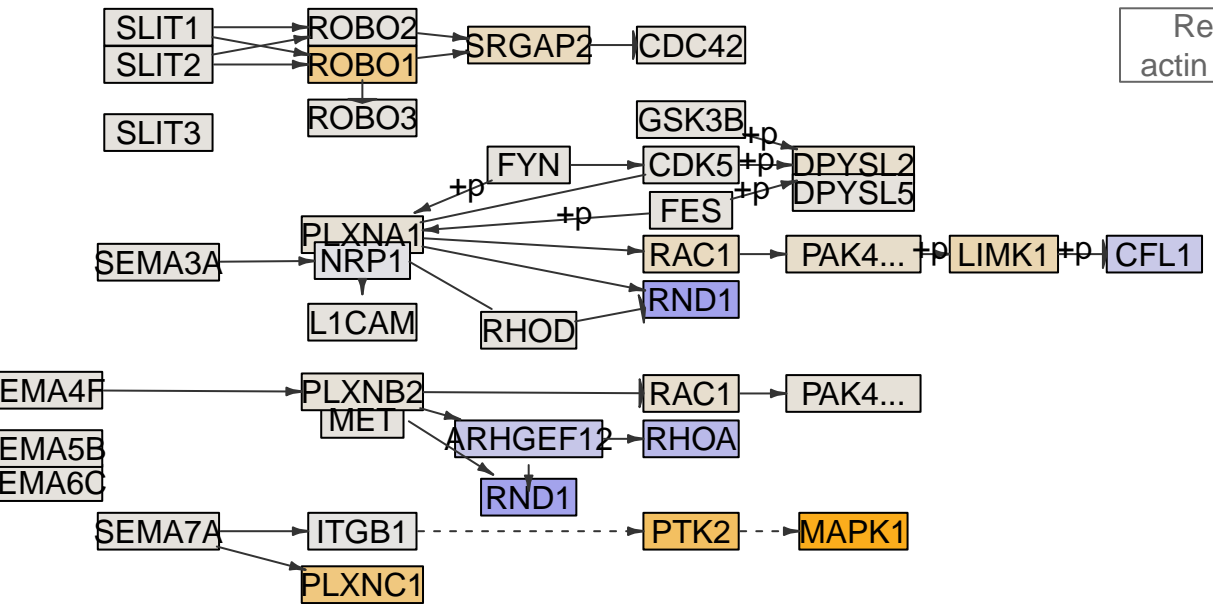

Regulation of actin cytoskeleton

Regulation of actin cytoskeleton

Axon guidance
MPI-050

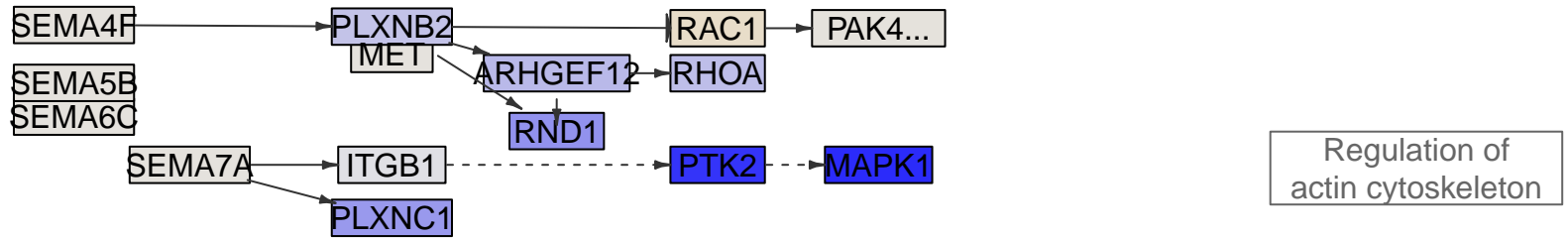
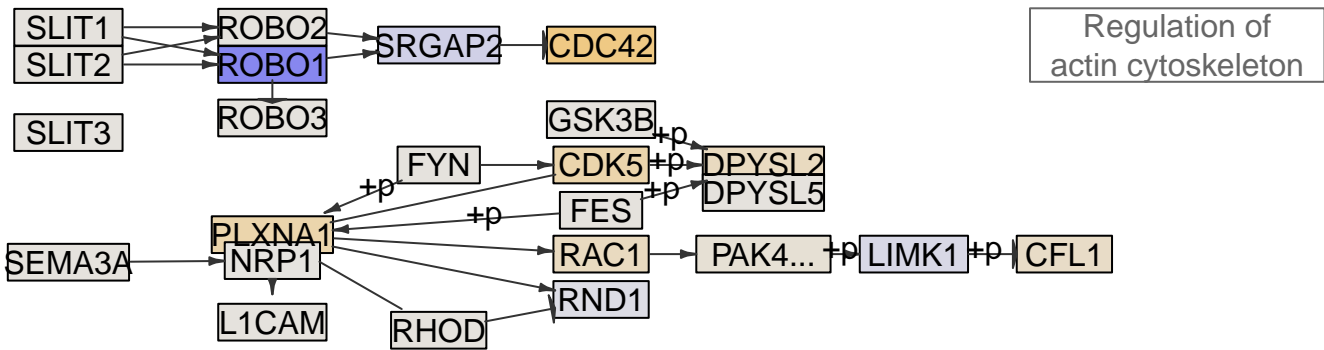
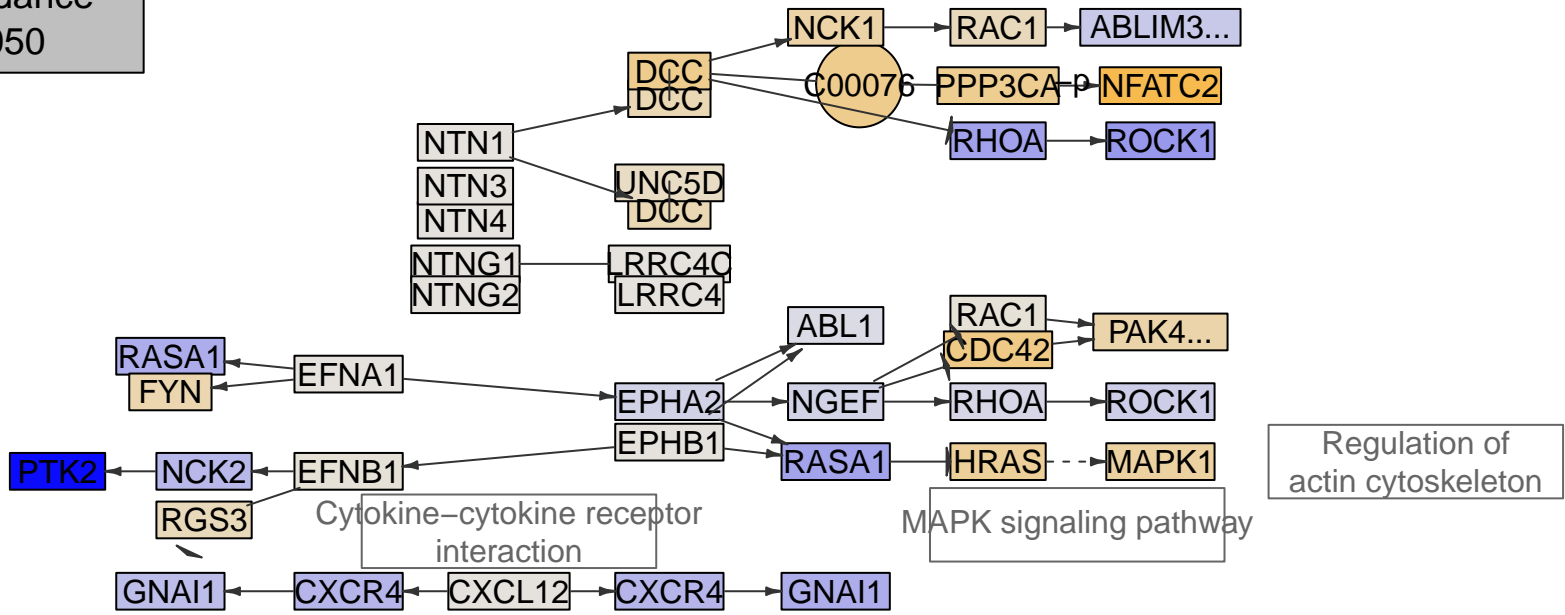

Axon guidance
MPI-051

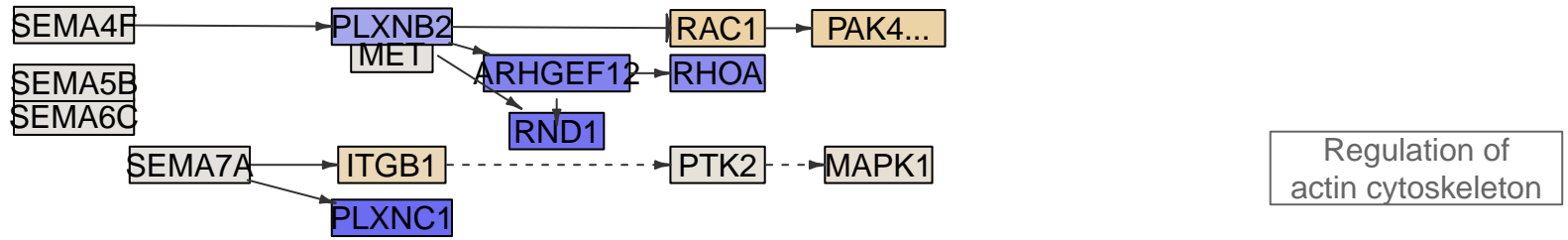
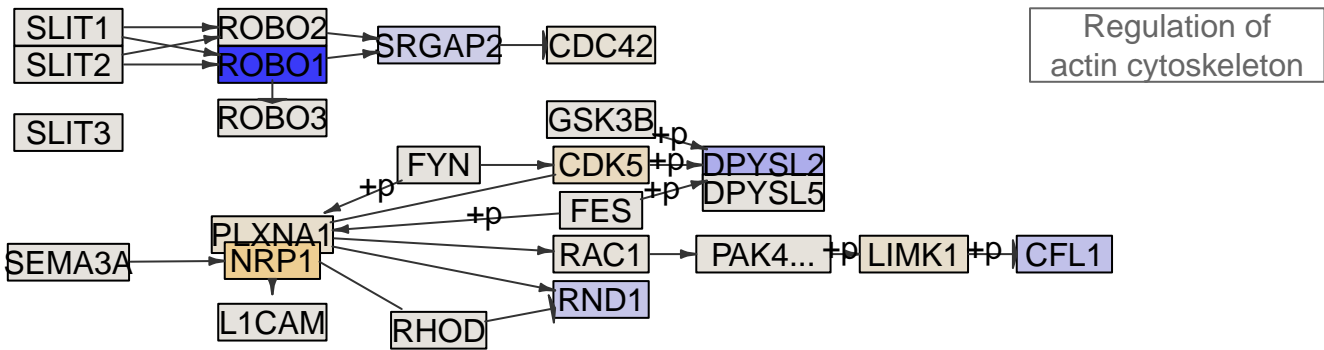
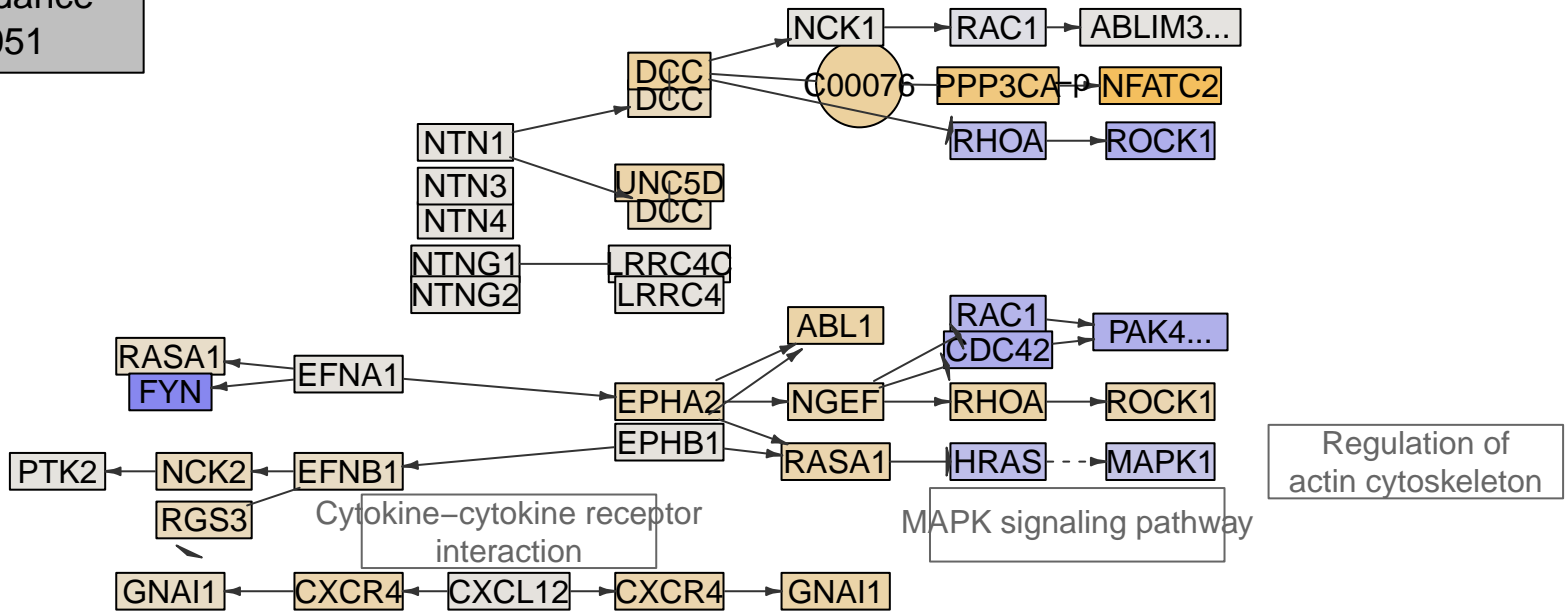

Axon guidance
MPI-054

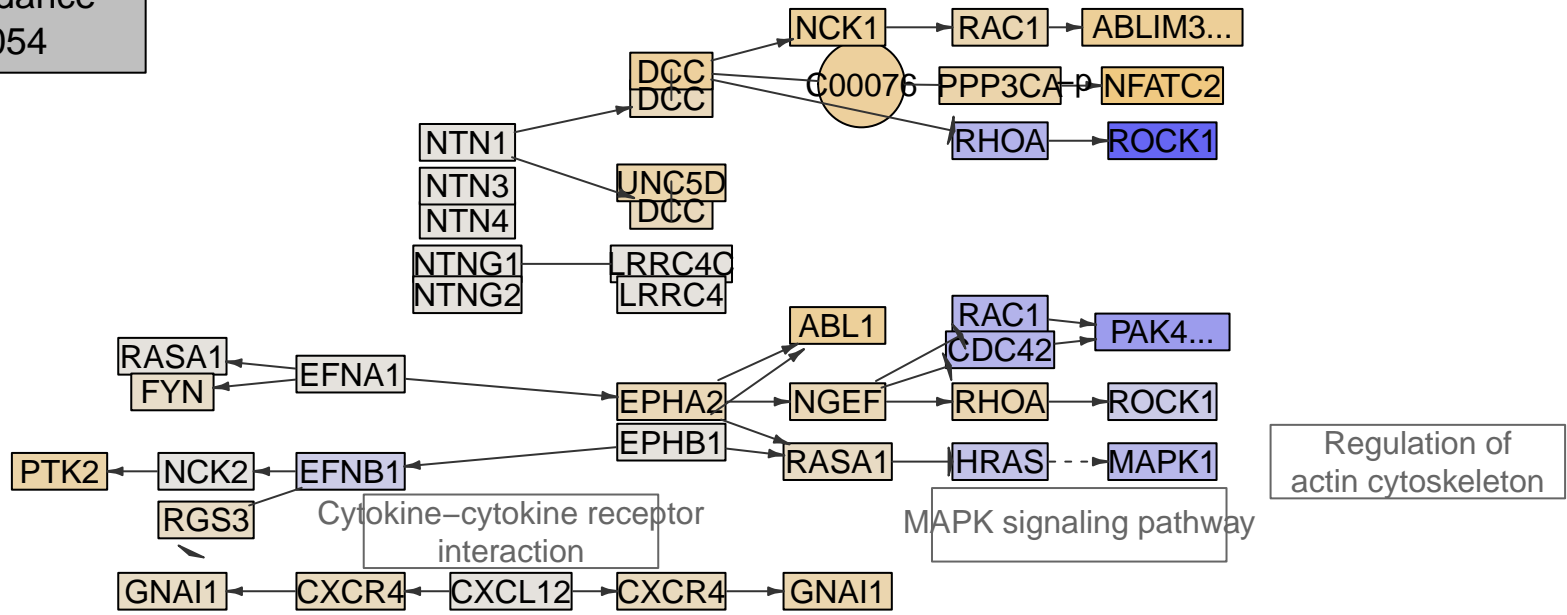

Regulation of actin cytoskeleton

MAPK signaling pathway

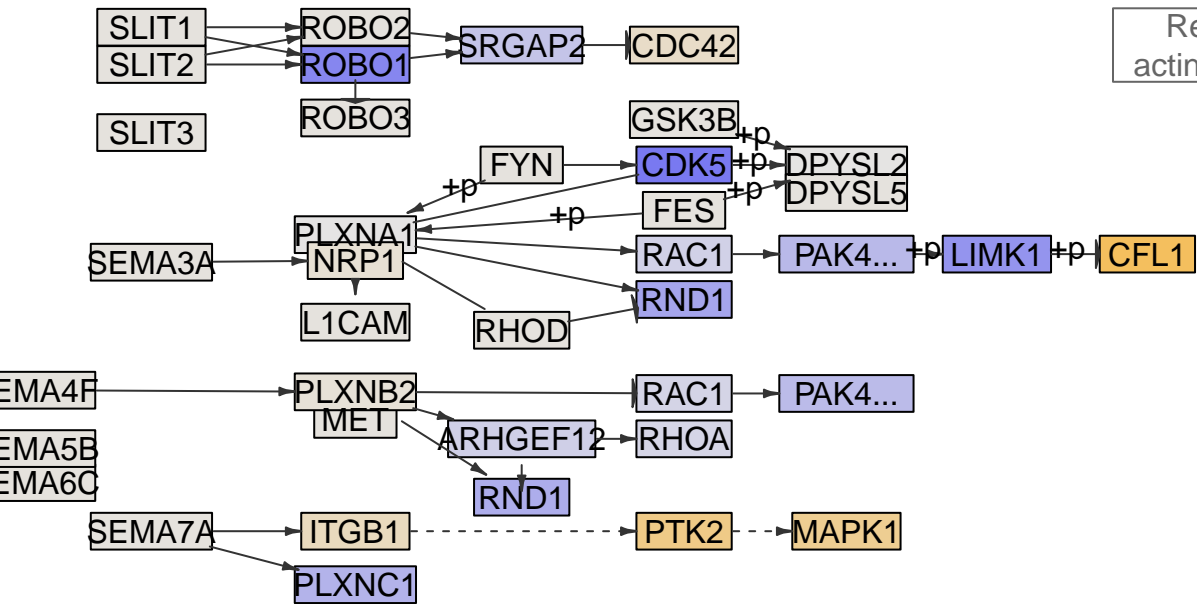

Regulation of actin cytoskeleton

Regulation of actin cytoskeleton

Axon guidance
MPI-059

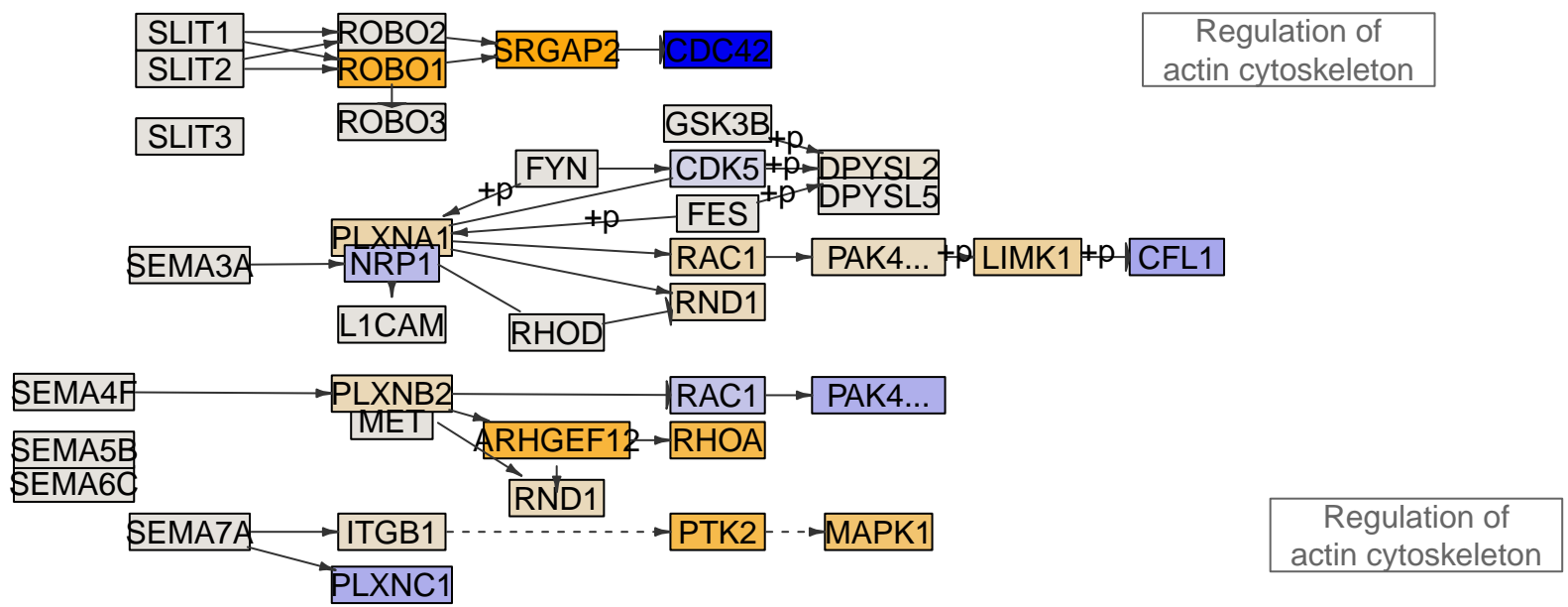
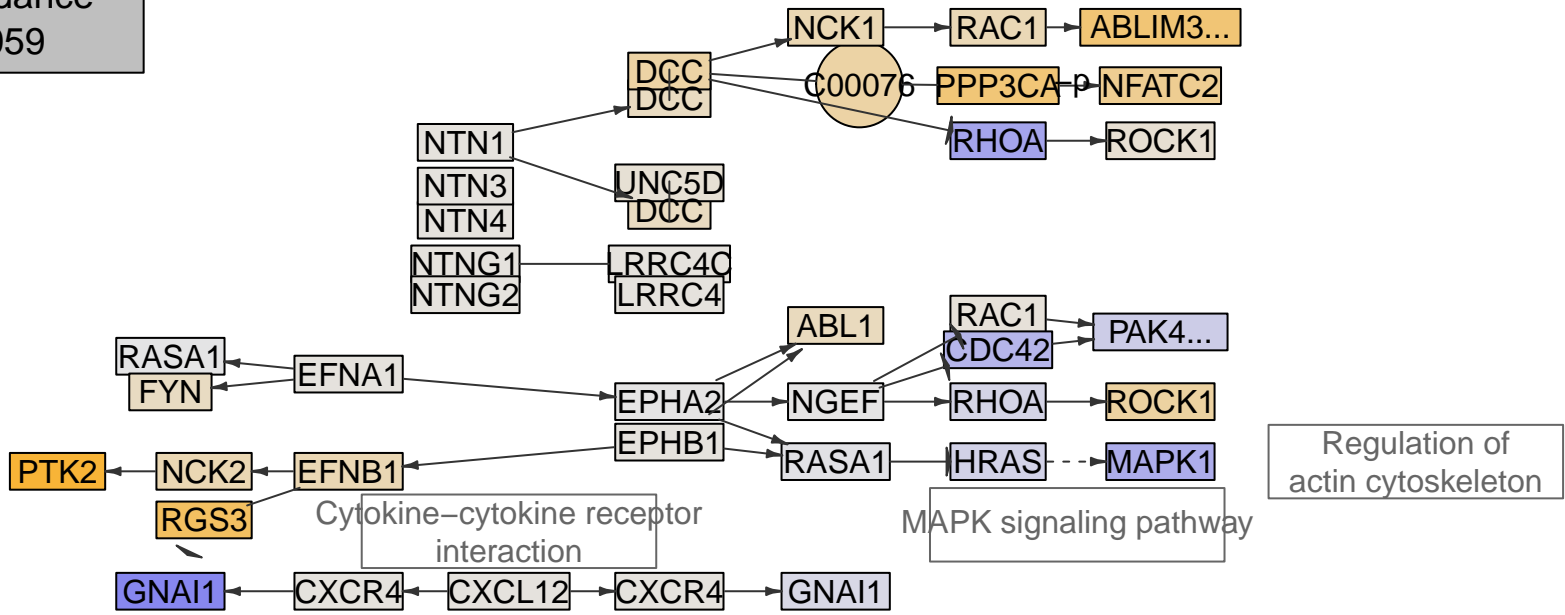

Axon guidance
MPI-060

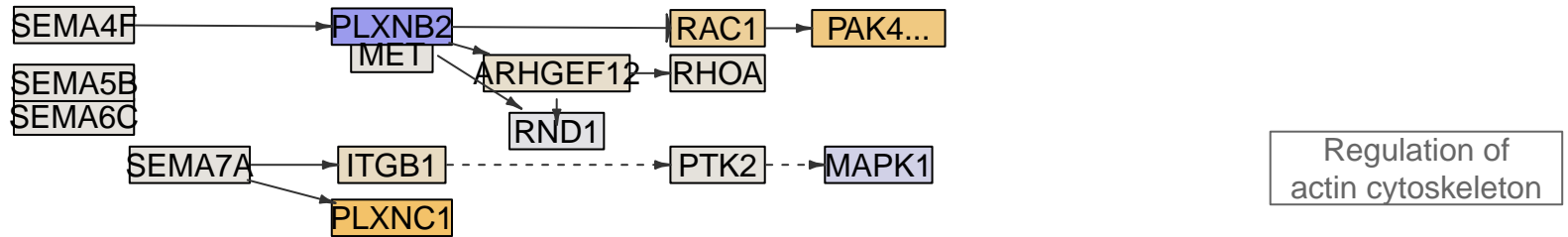
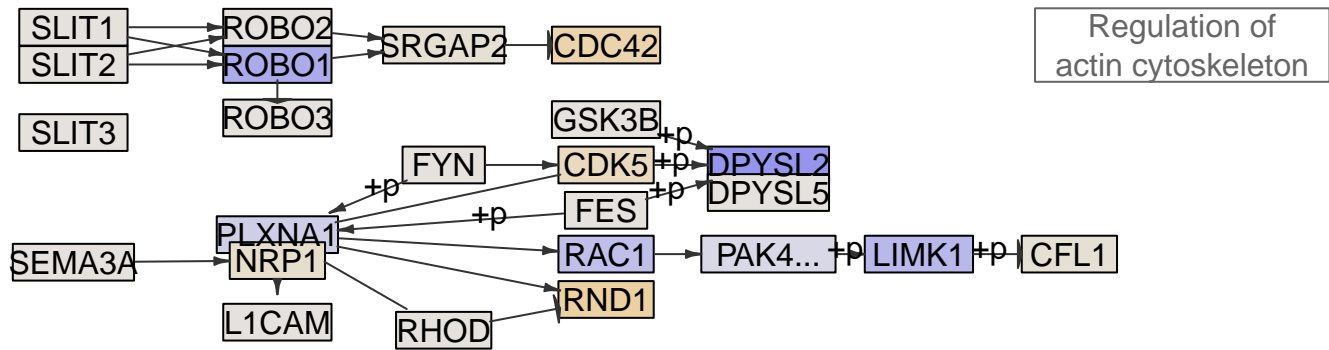
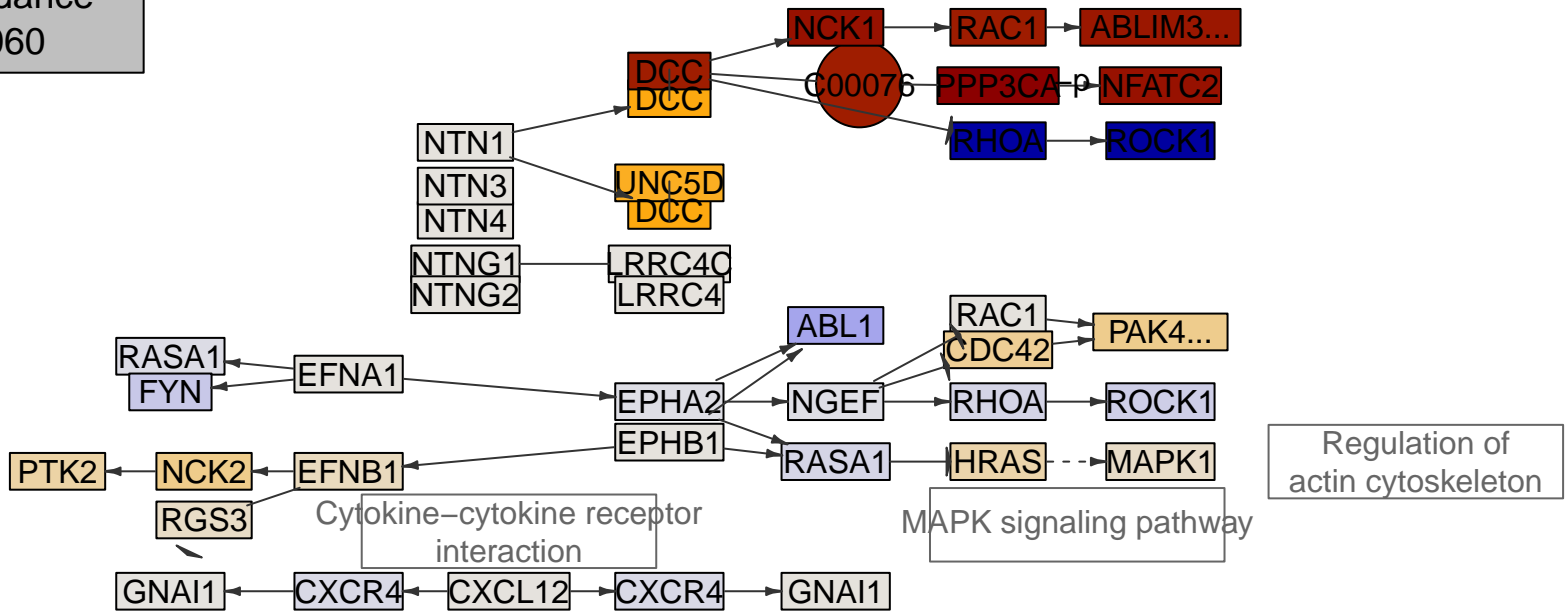

Regulation of actin cytoskeleton

Axon guidance
MPI-061

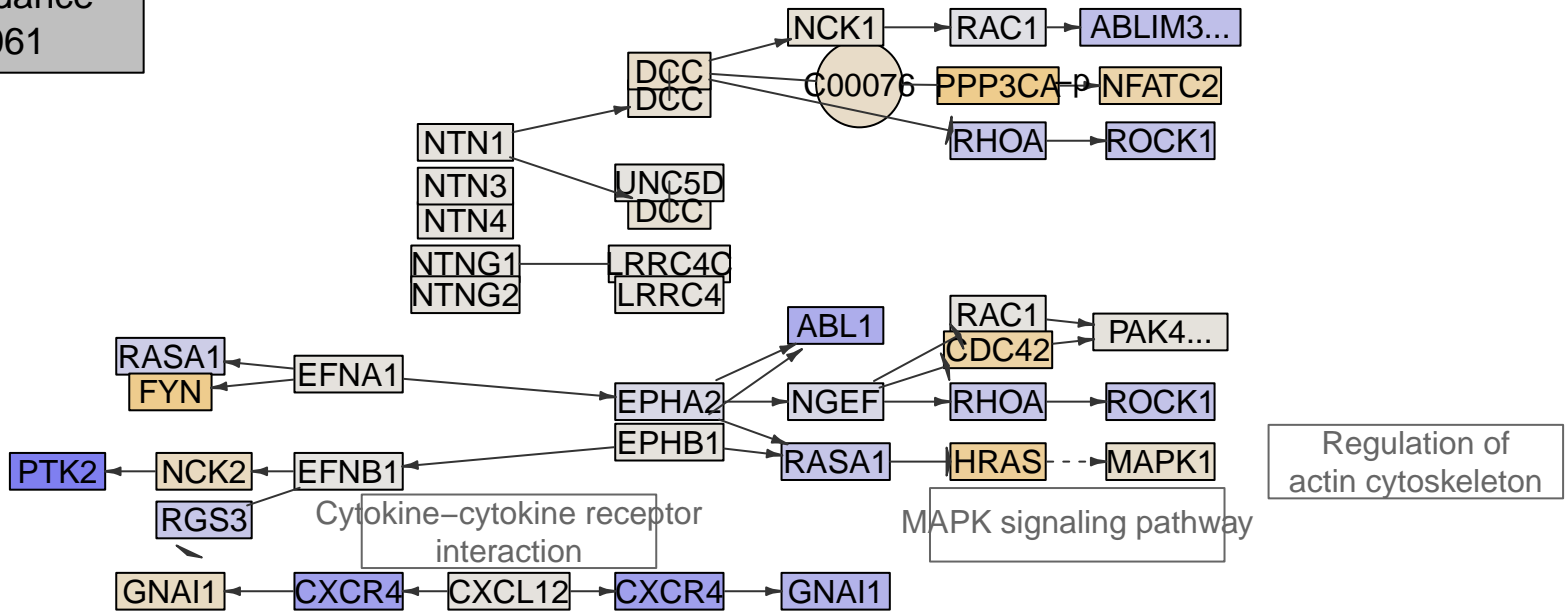

Regulation of actin cytoskeleton

MAPK signaling pathway

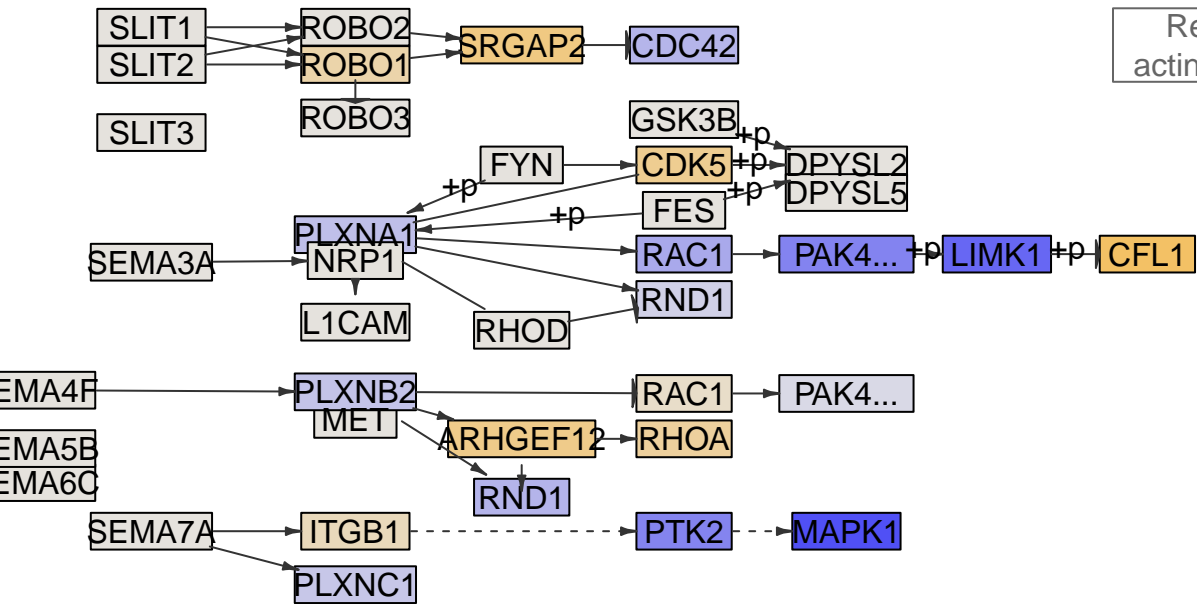

Regulation of actin cytoskeleton

Regulation of actin cytoskeleton

Axon guidance
MPI-064

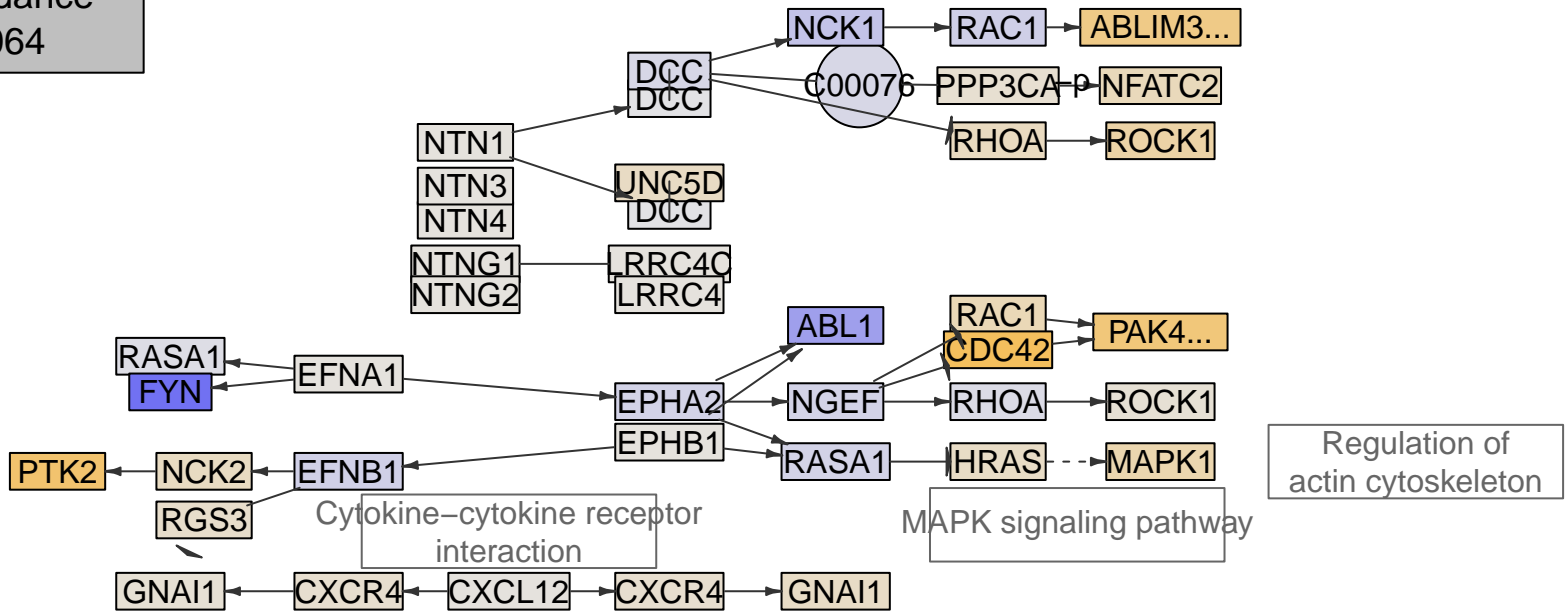

Regulation of actin cytoskeleton

MAPK signaling pathway

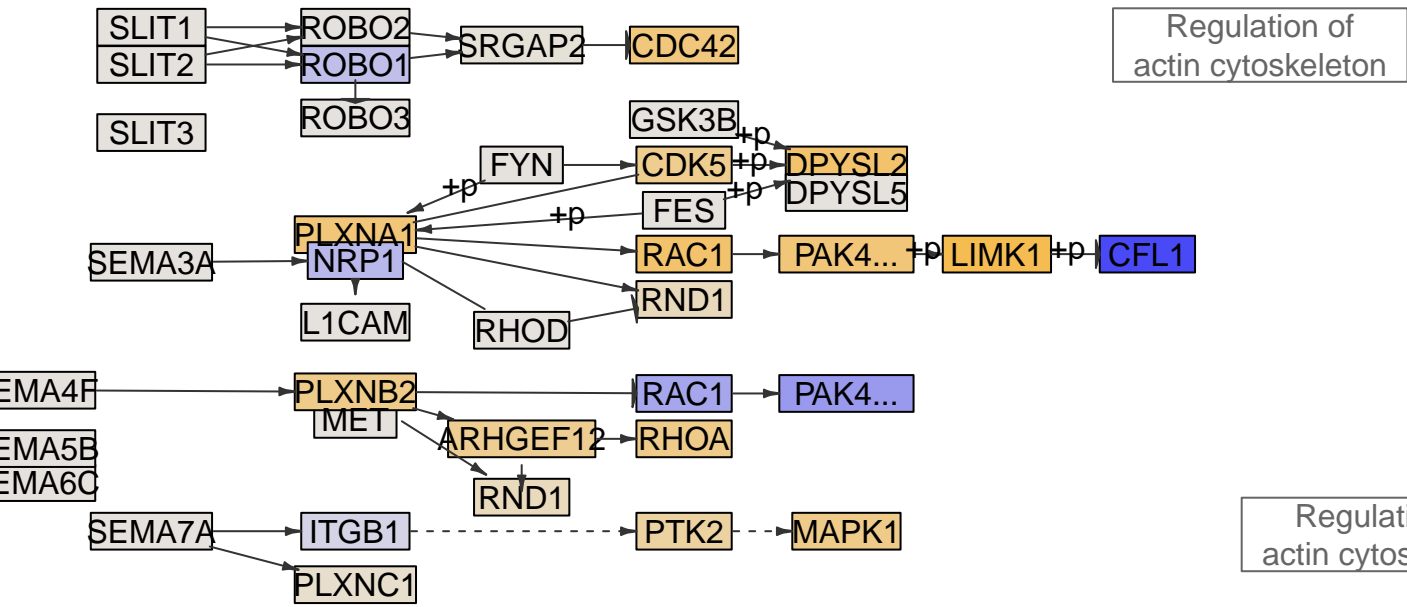

Regulation of actin cytoskeleton

Regulation of actin cytoskeleton

Axon guidance
MPI-070

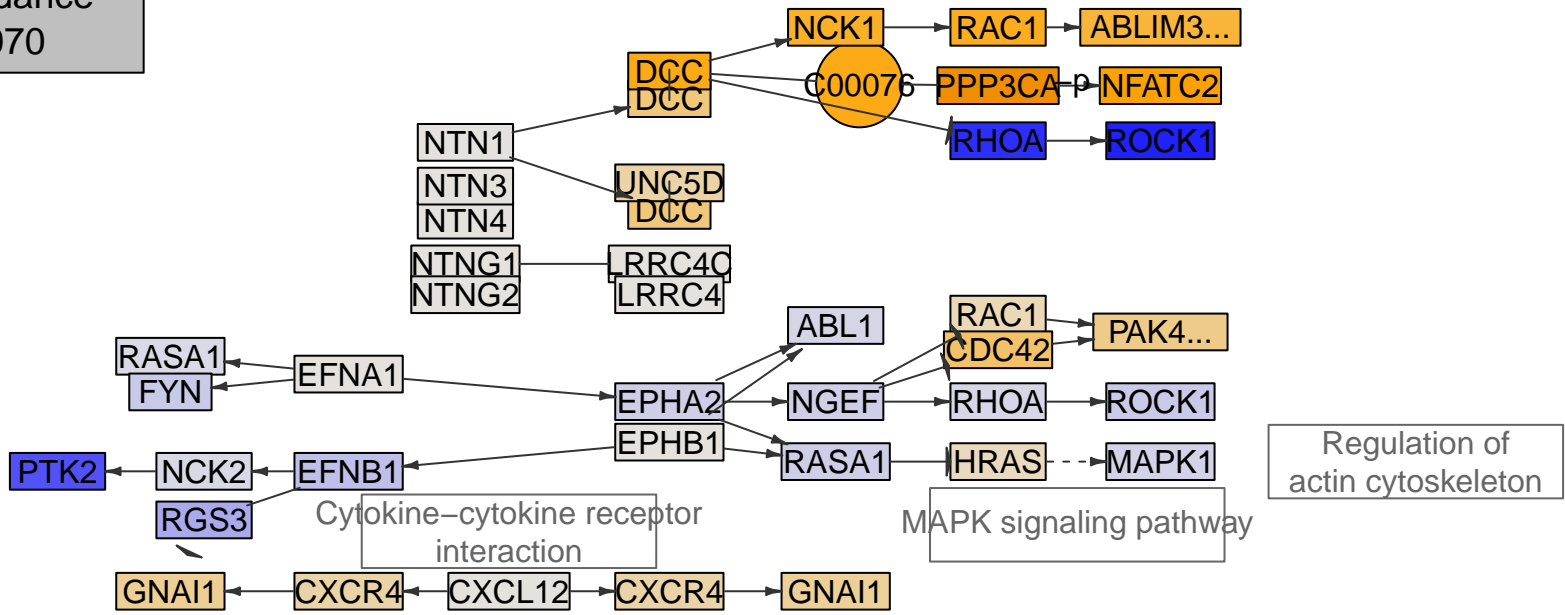

Regulation of actin cytoskeleton

MAPK signaling pathway

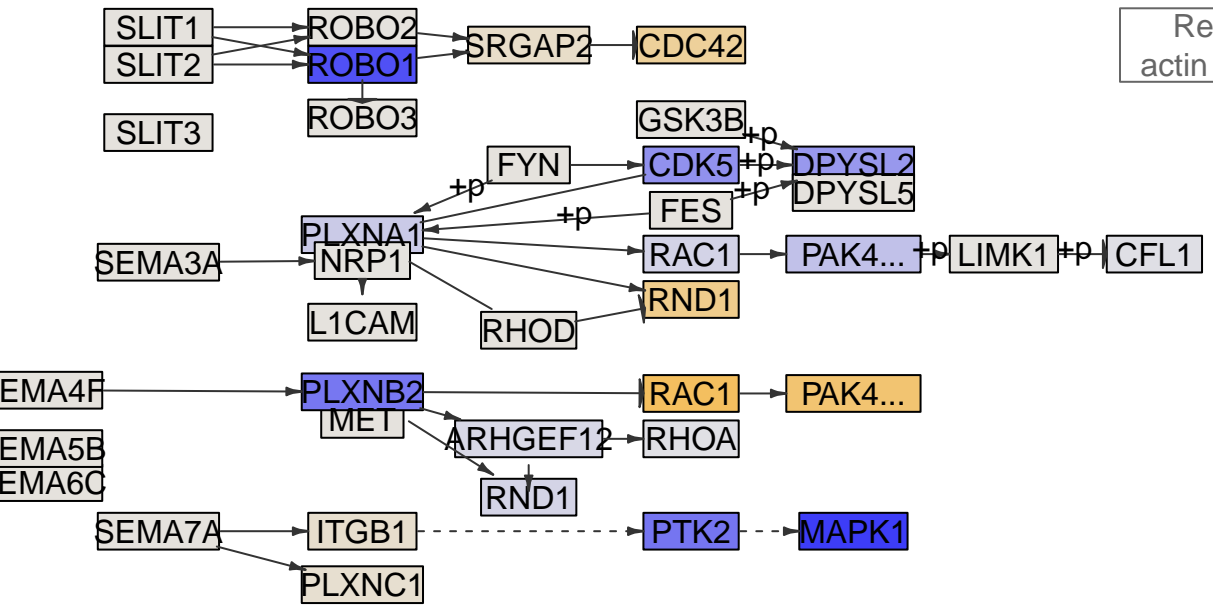

Regulation of actin cytoskeleton

Regulation of actin cytoskeleton

Axon guidance
MPI-072

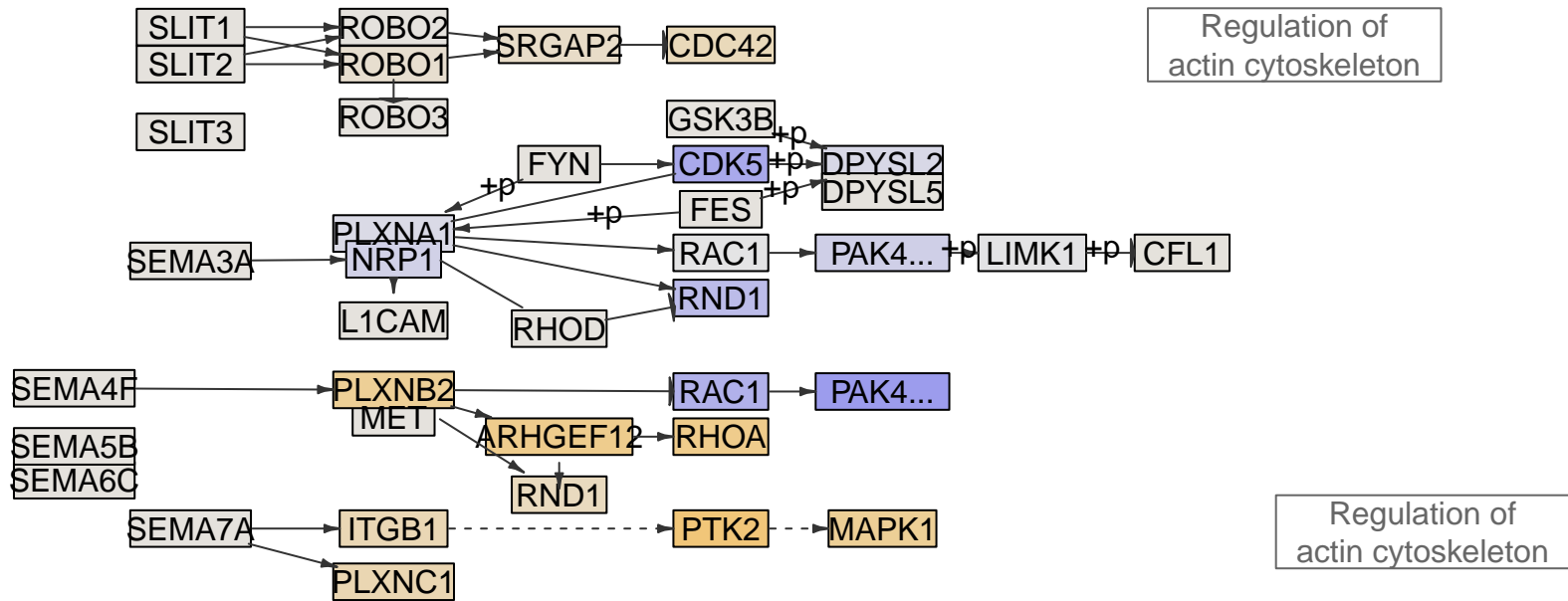
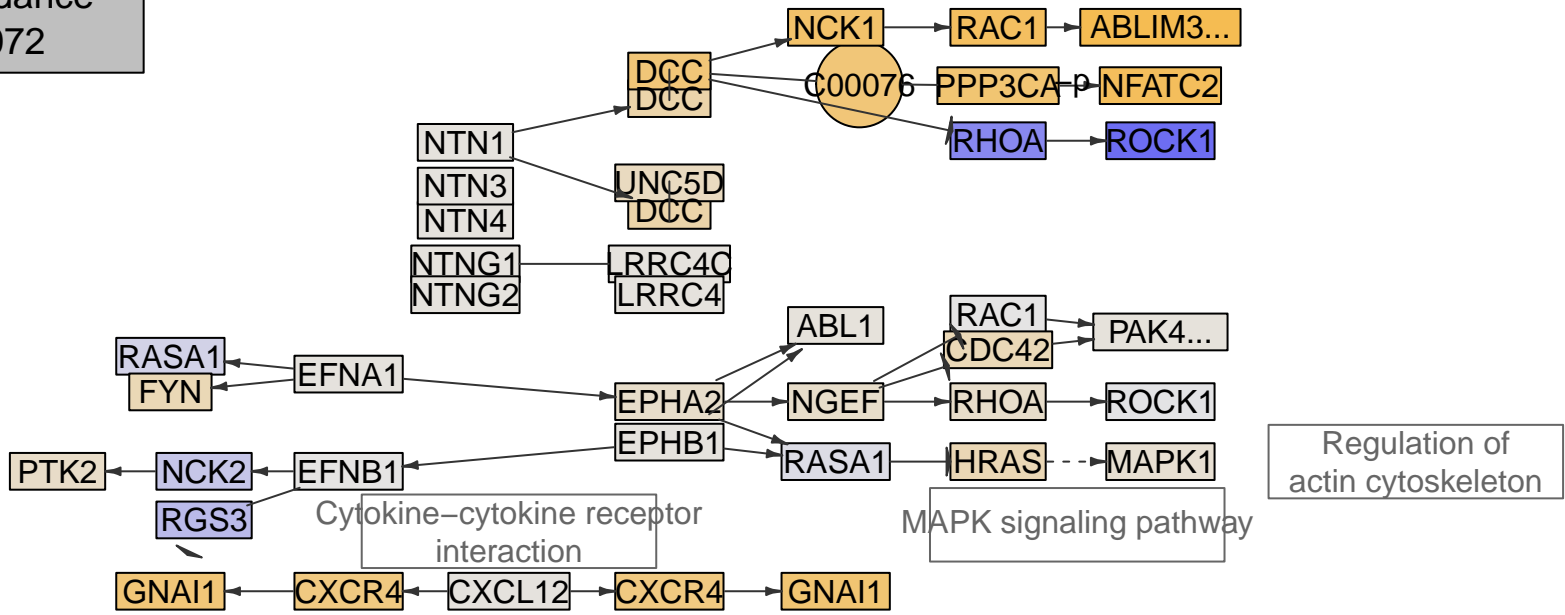

Axon guidance
MPI-093

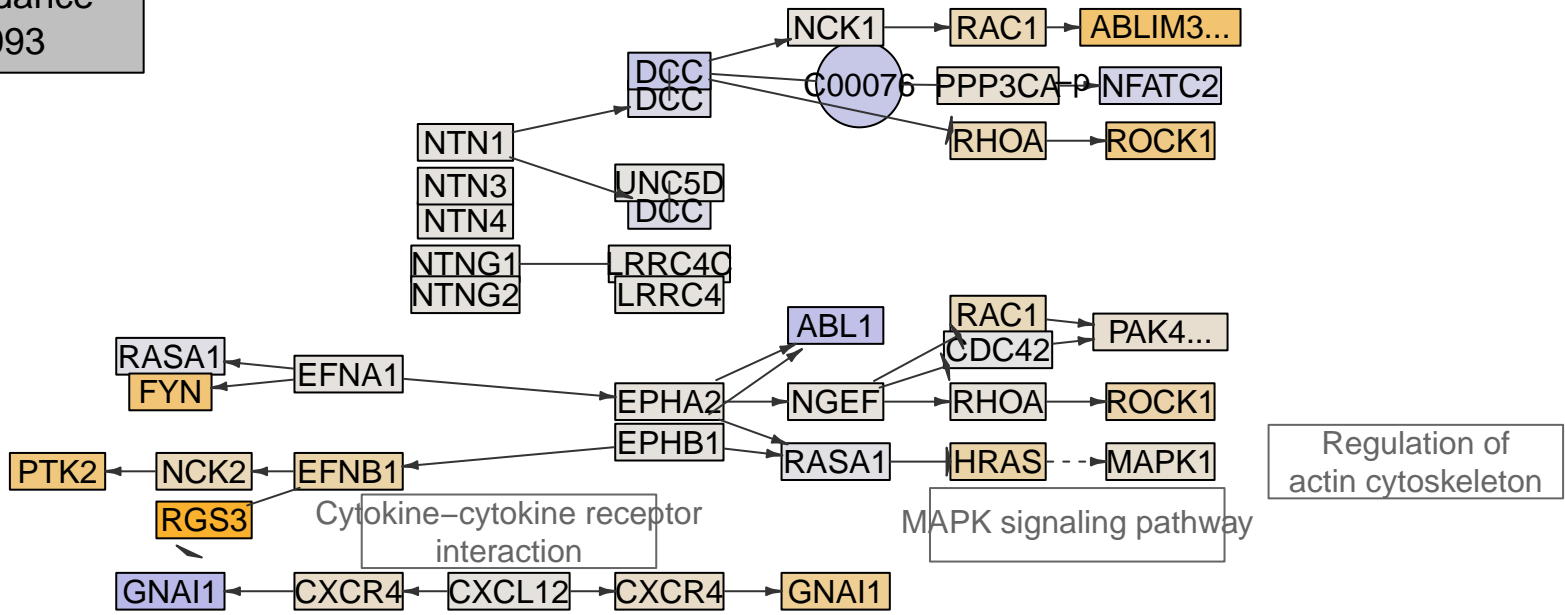

Regulation of actin cytoskeleton

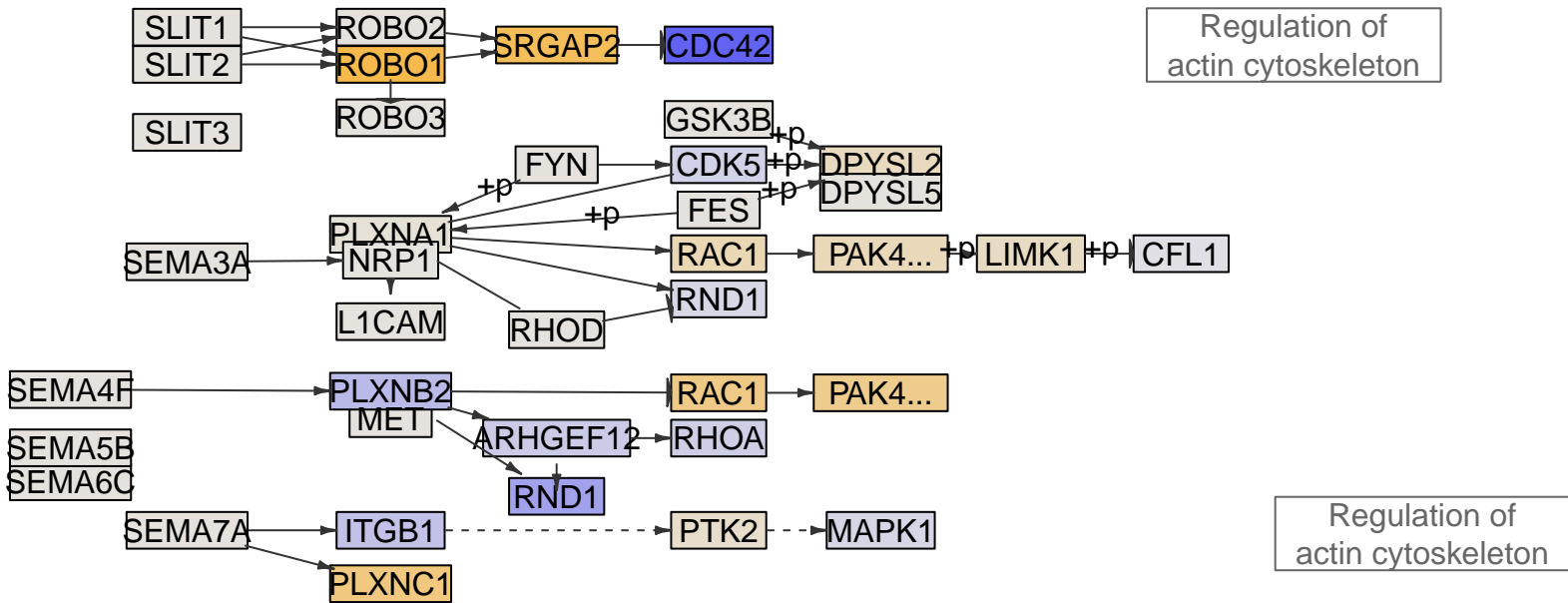

Regulation of actin cytoskeleton

Regulation of actin cytoskeleton

Axon guidance
MPI-094

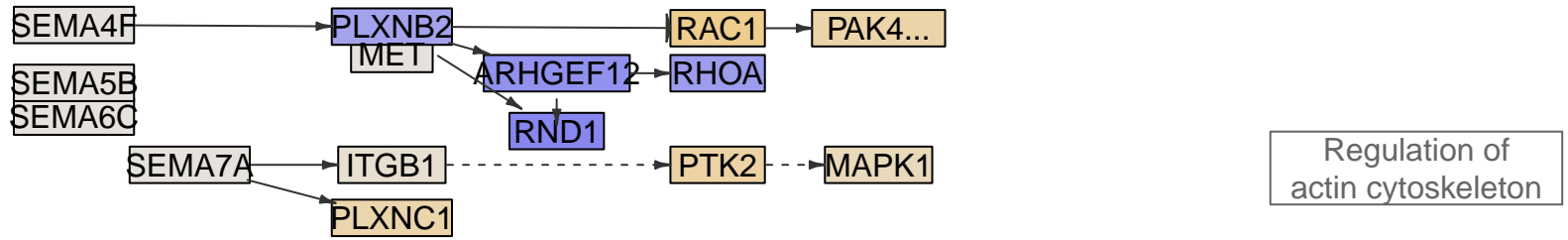
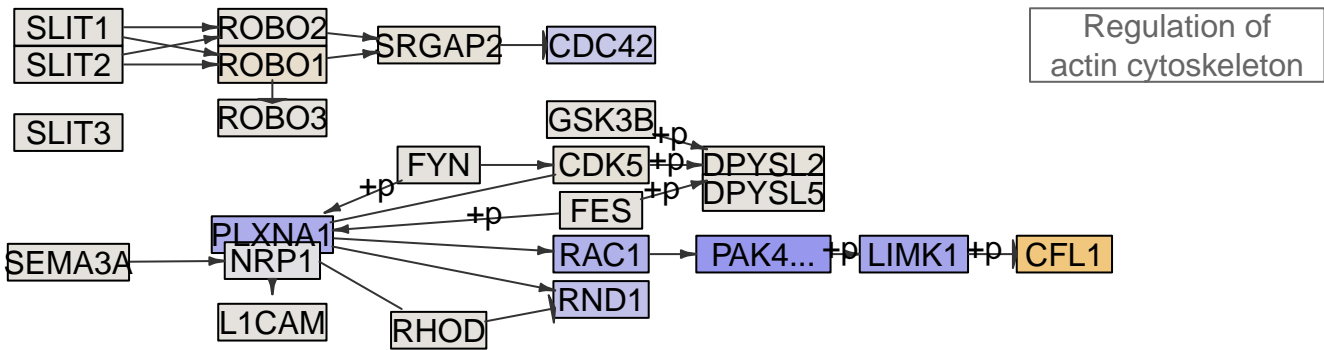
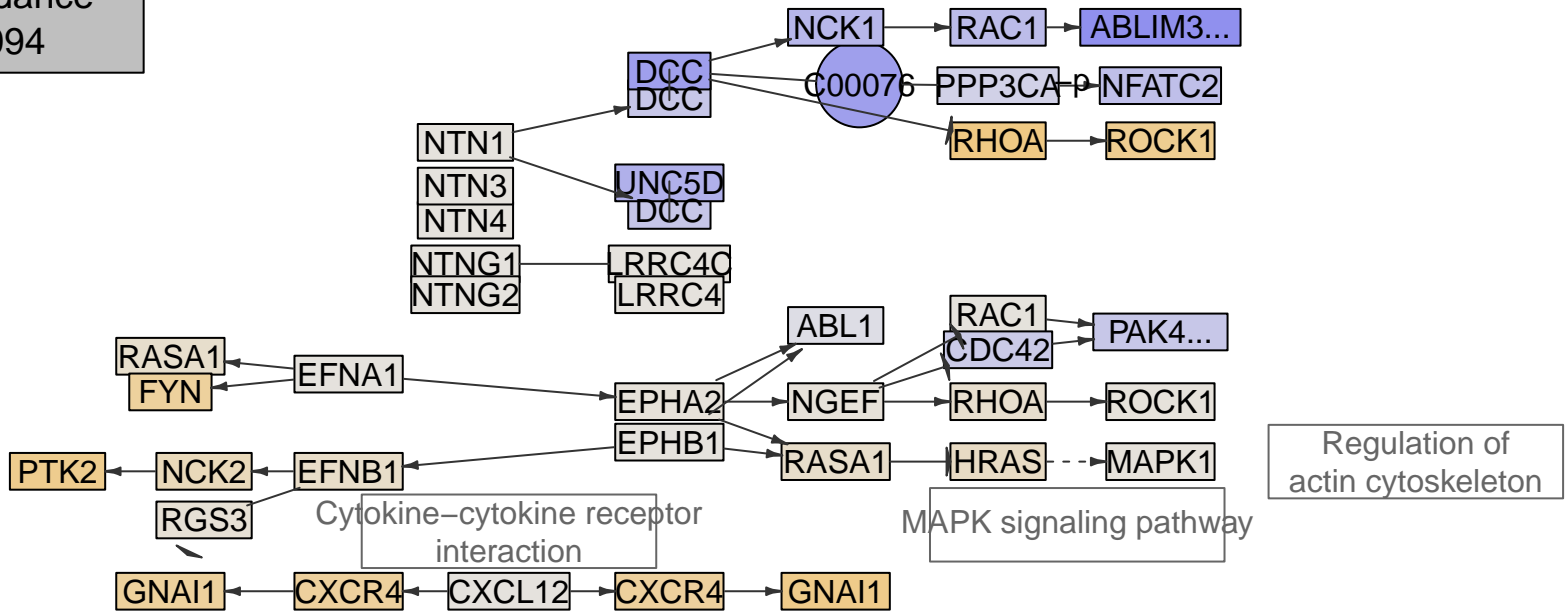

Axon guidance
MPI-099

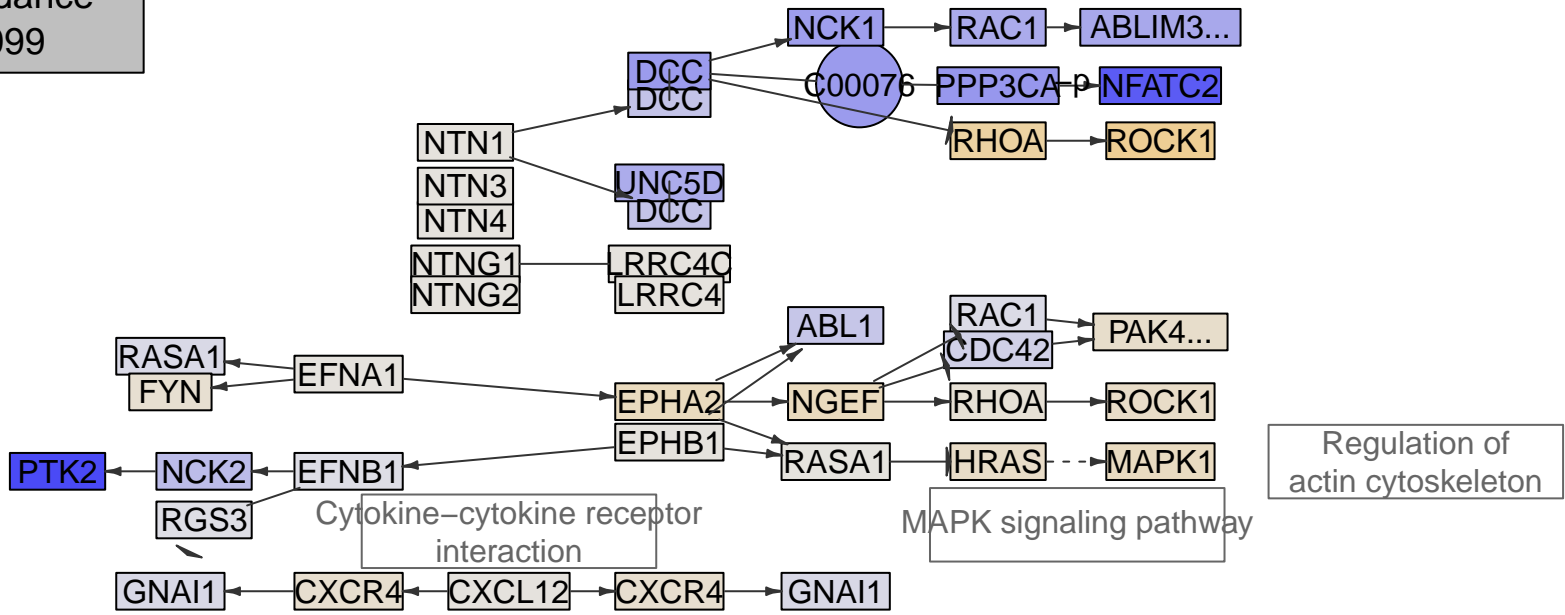

Regulation of actin cytoskeleton

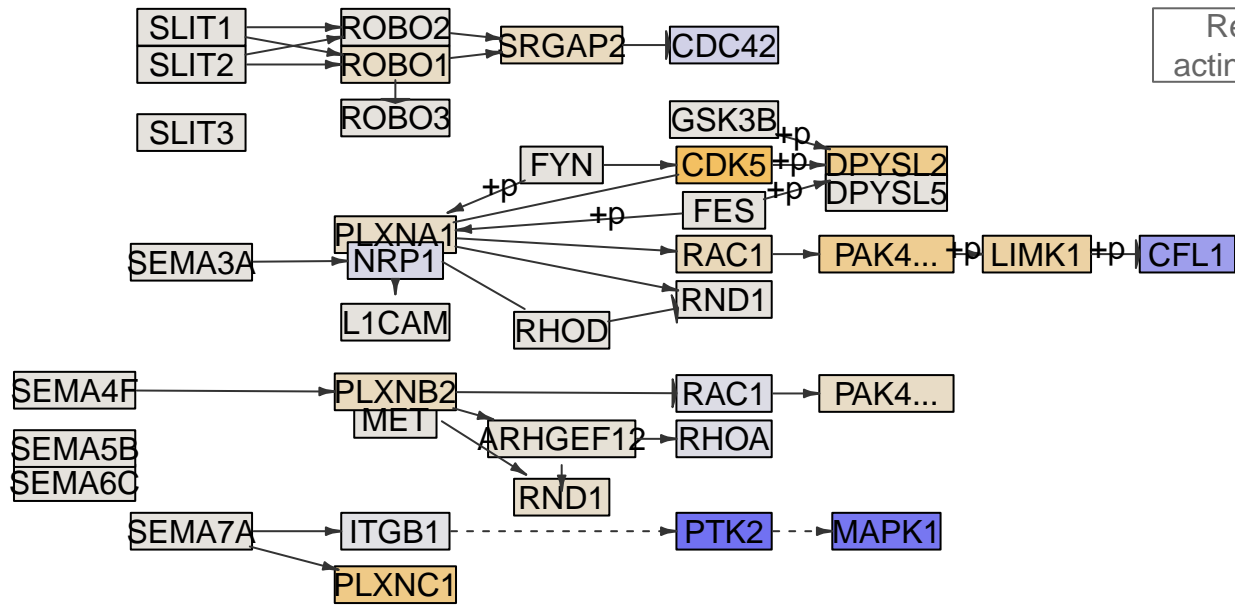

Regulation of actin cytoskeleton

Regulation of actin cytoskeleton

Axon guidance
MPI-104

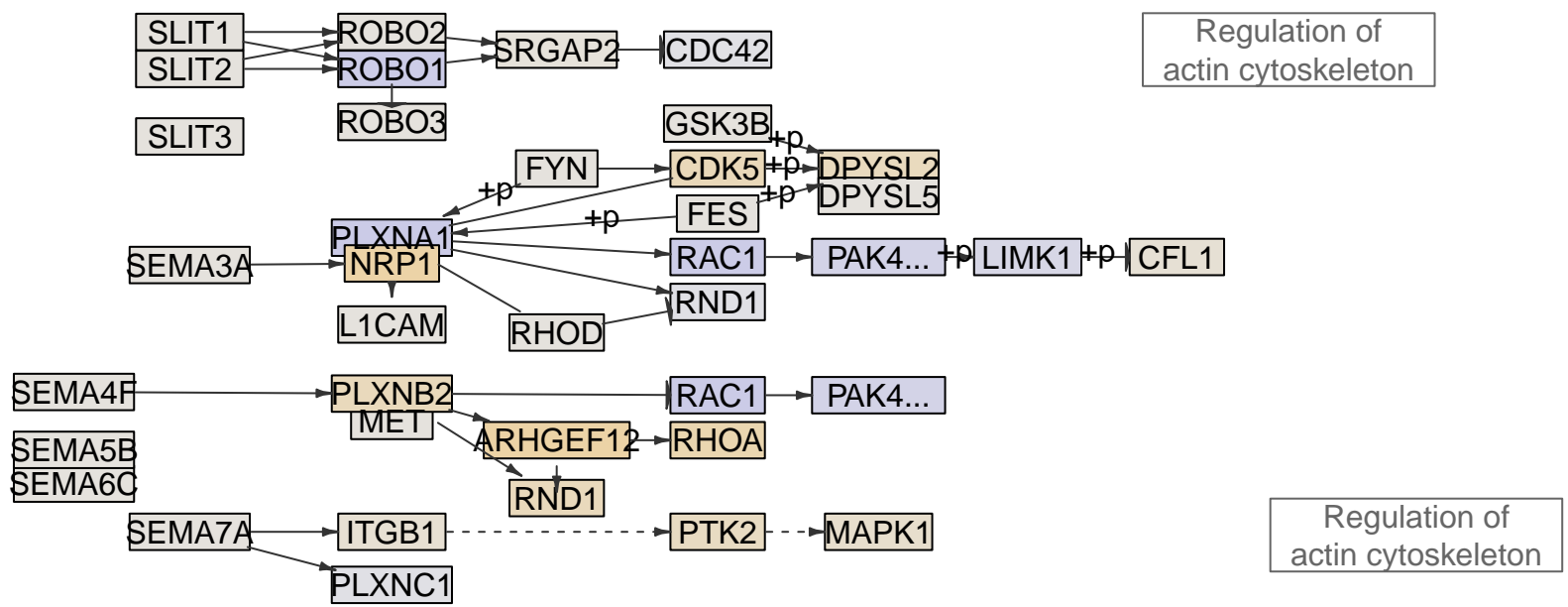
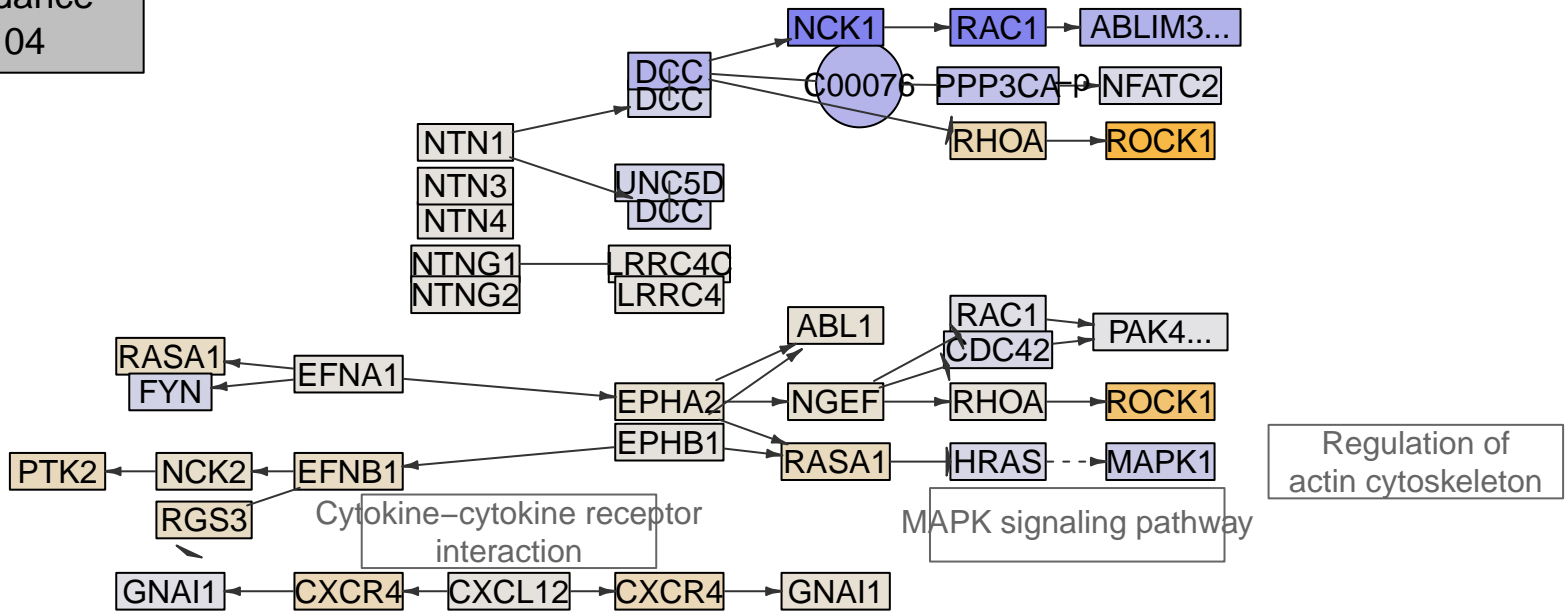

Axon guidance
MPI-107

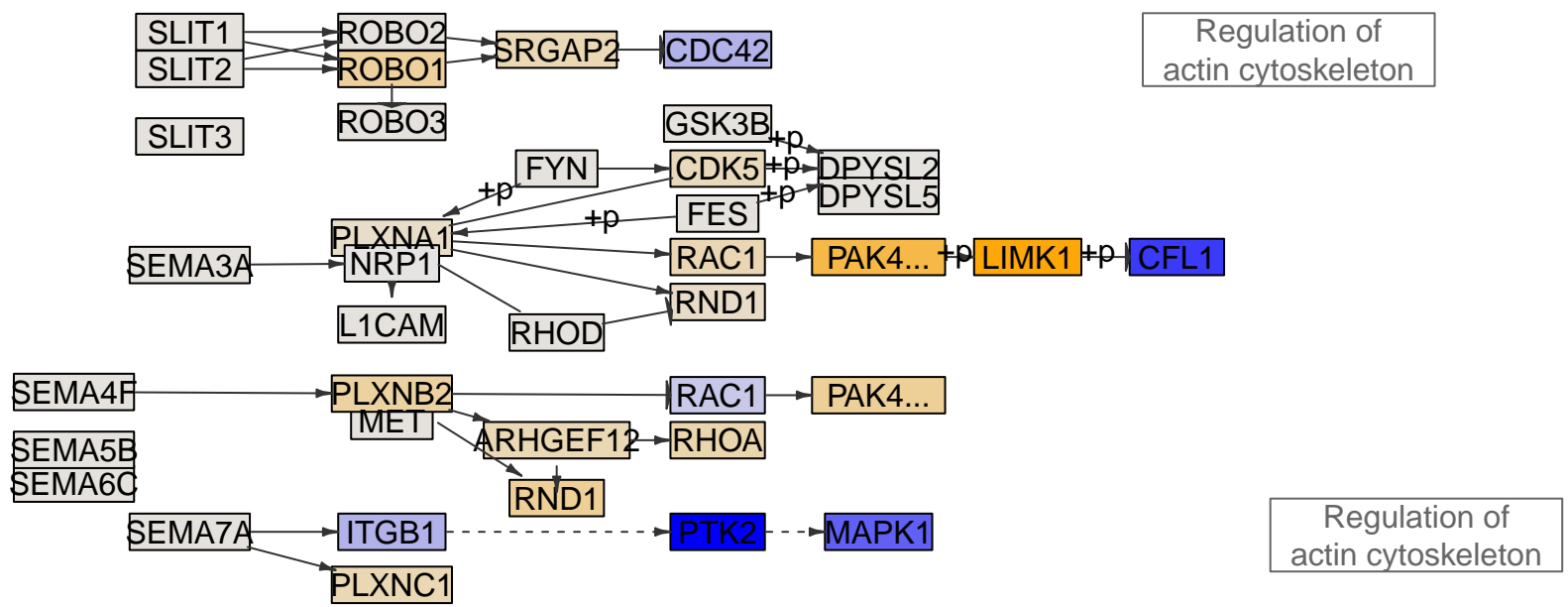
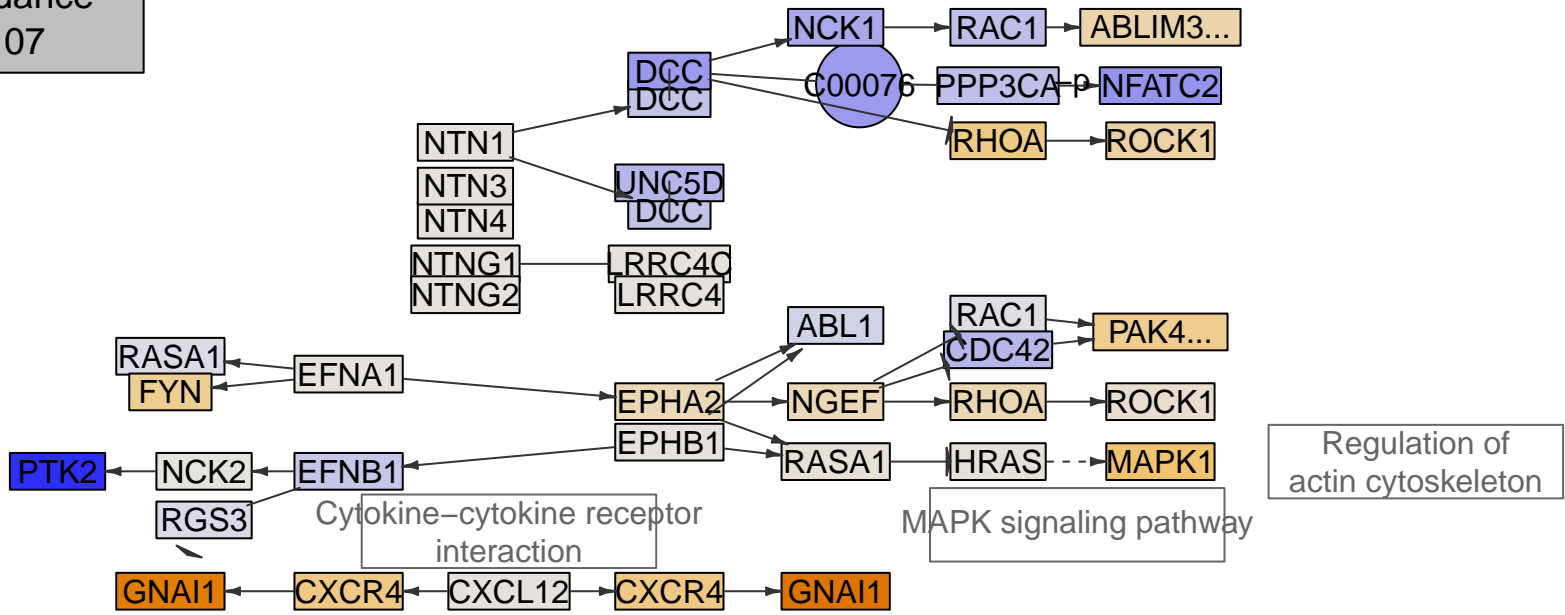

Axon guidance
MPI-112

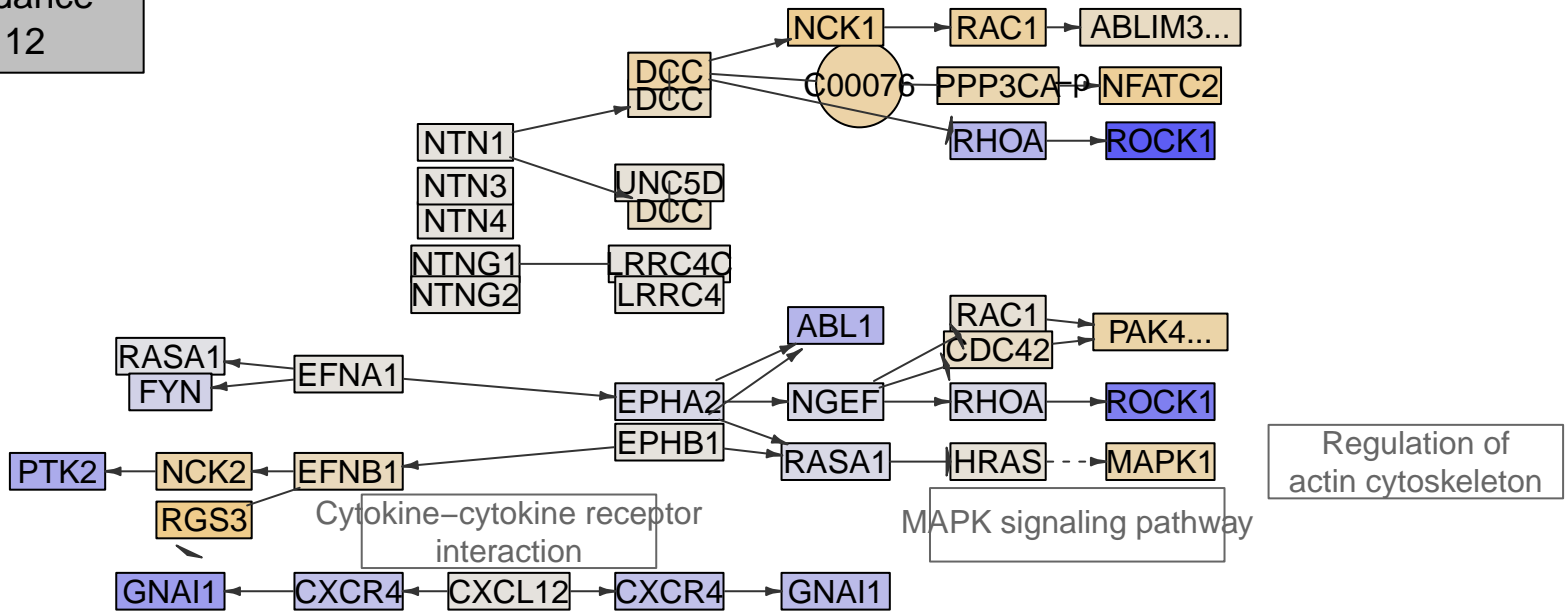

Regulation of actin cytoskeleton

MAPK signaling pathway

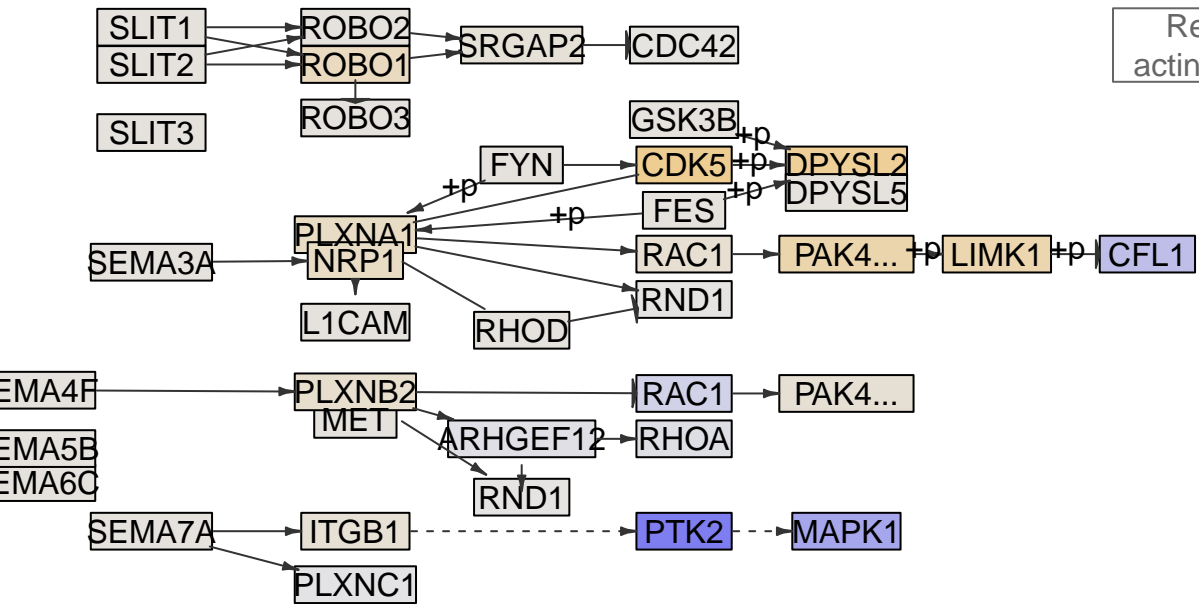

Regulation of actin cytoskeleton

Regulation of actin cytoskeleton

Axon guidance
MPI-116

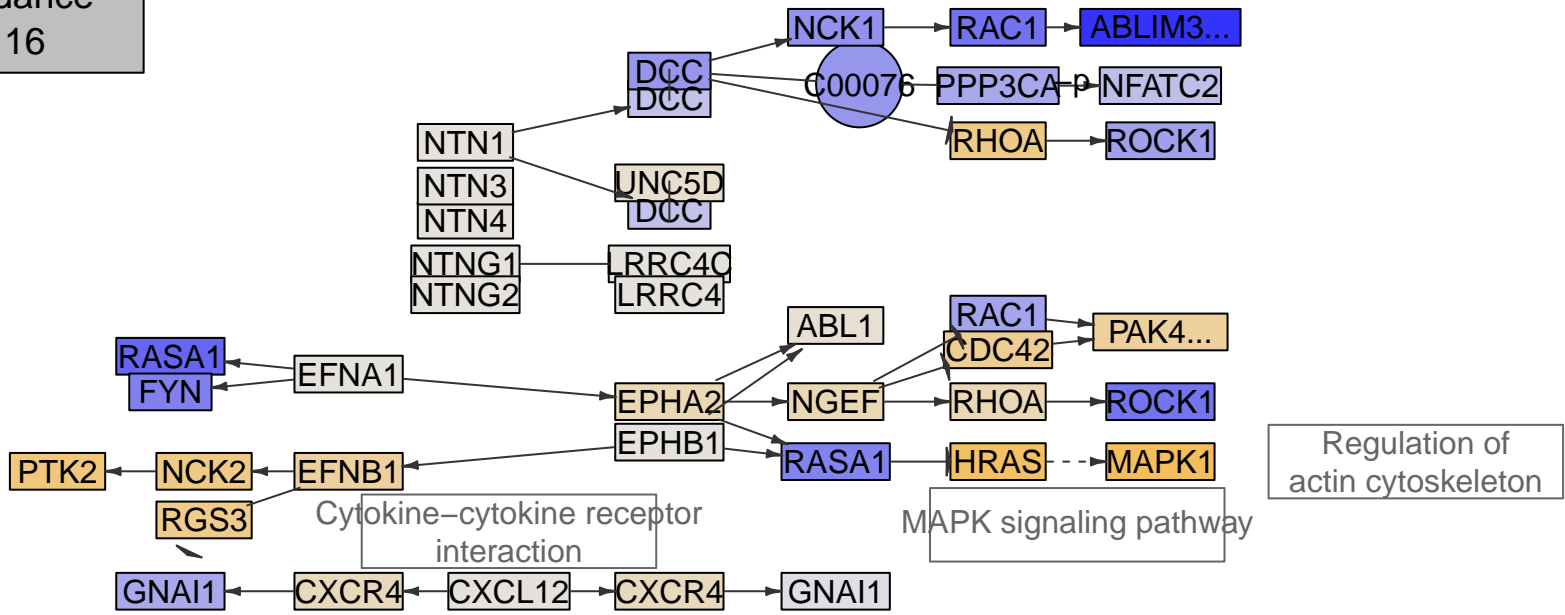

Regulation of actin cytoskeleton

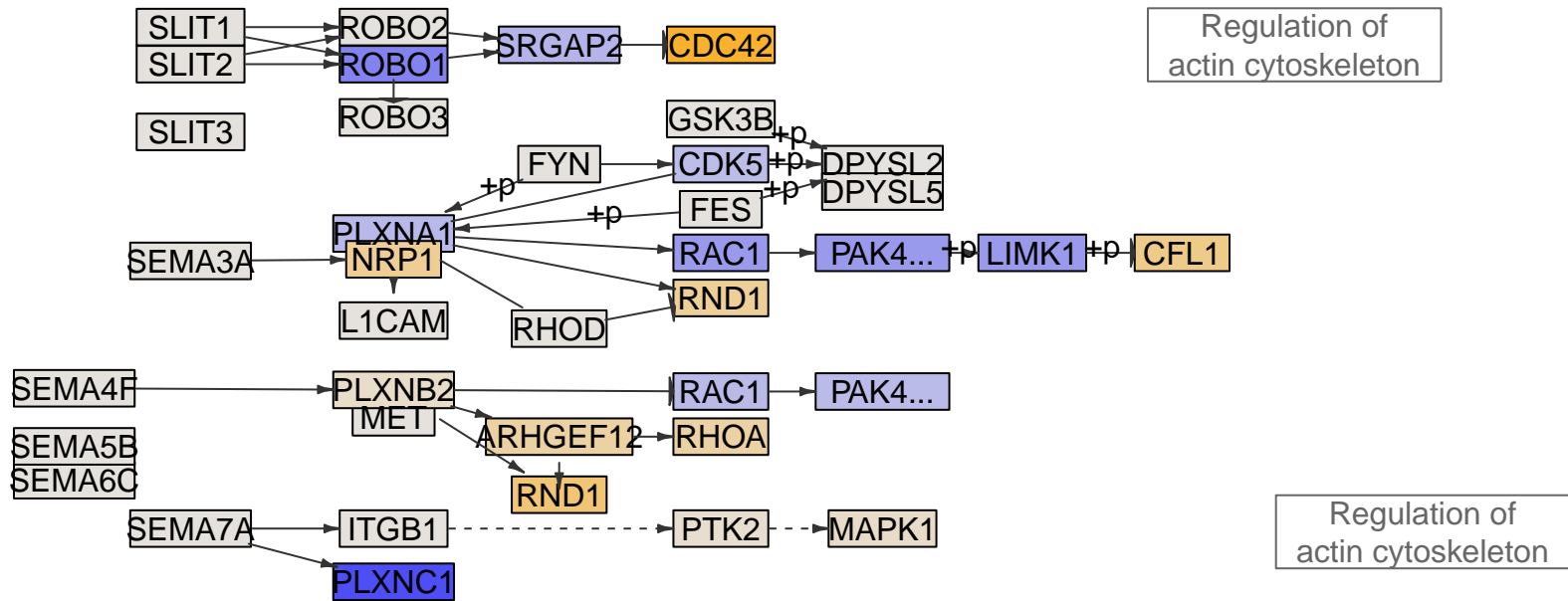

Regulation of actin cytoskeleton

Regulation of actin cytoskeleton

Axon guidance
MPI-117

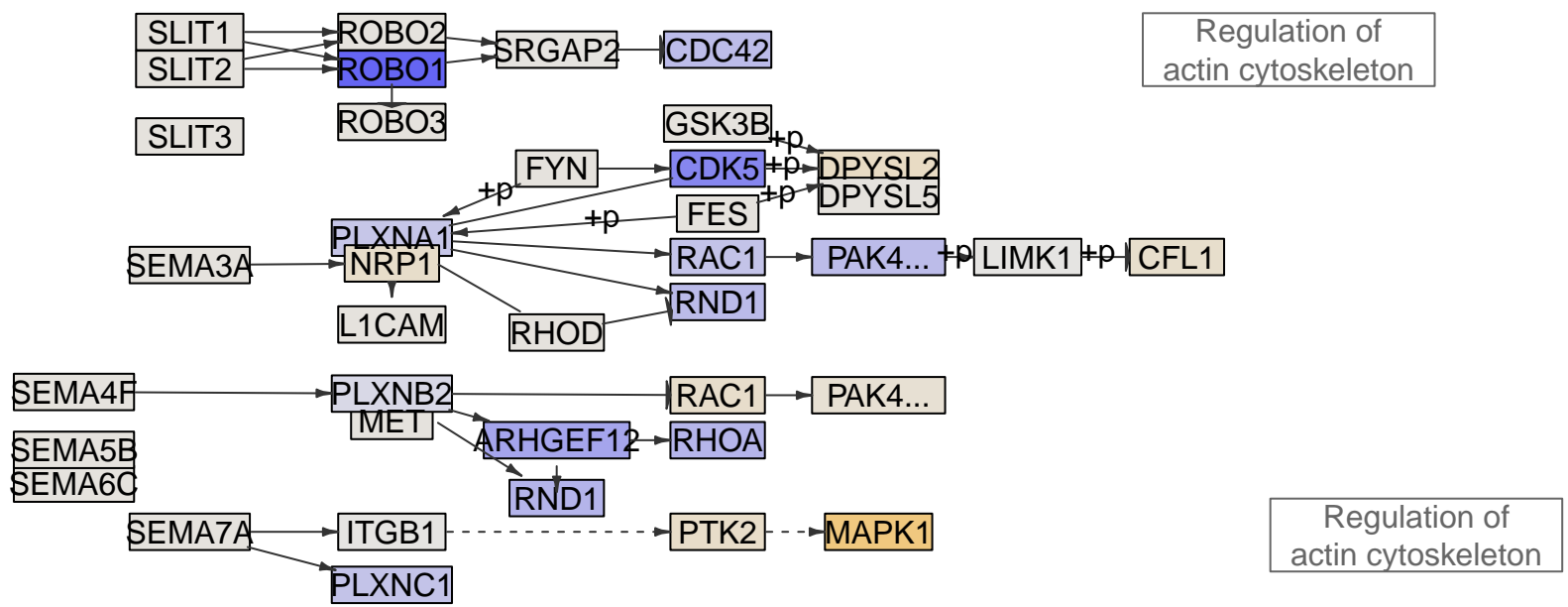
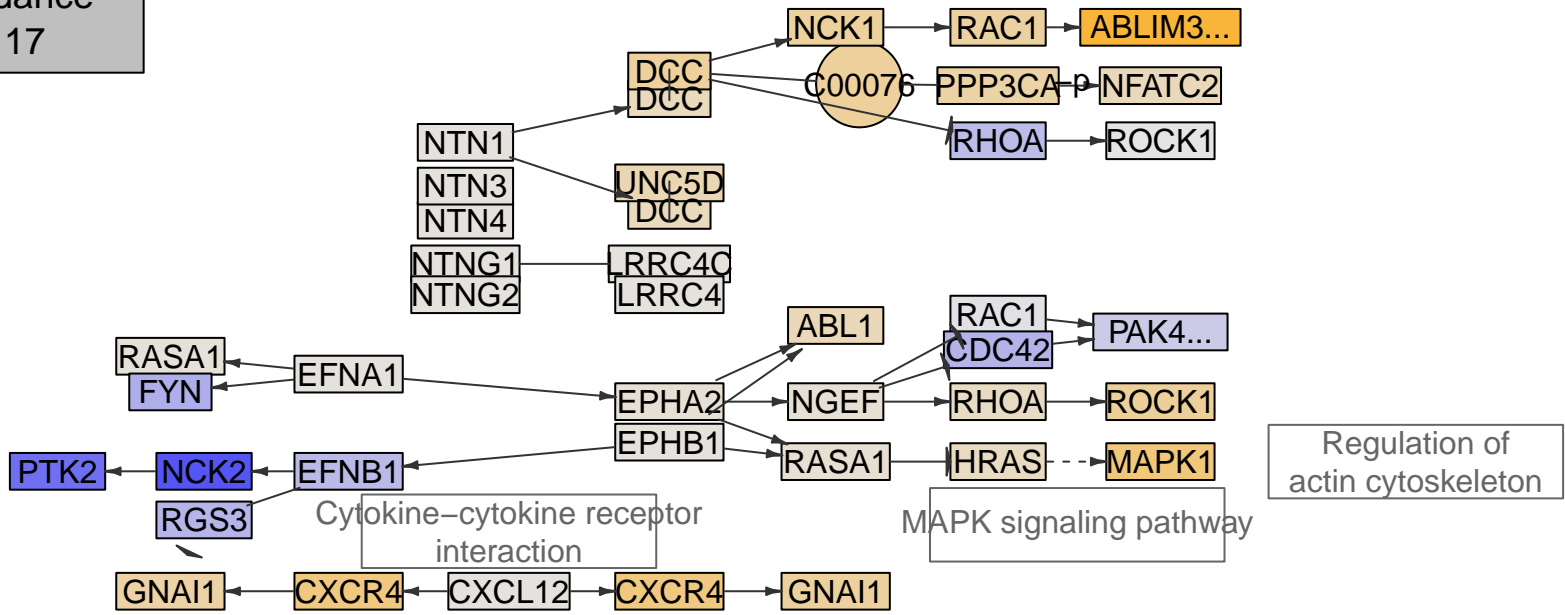

Axon guidance
MPI-120

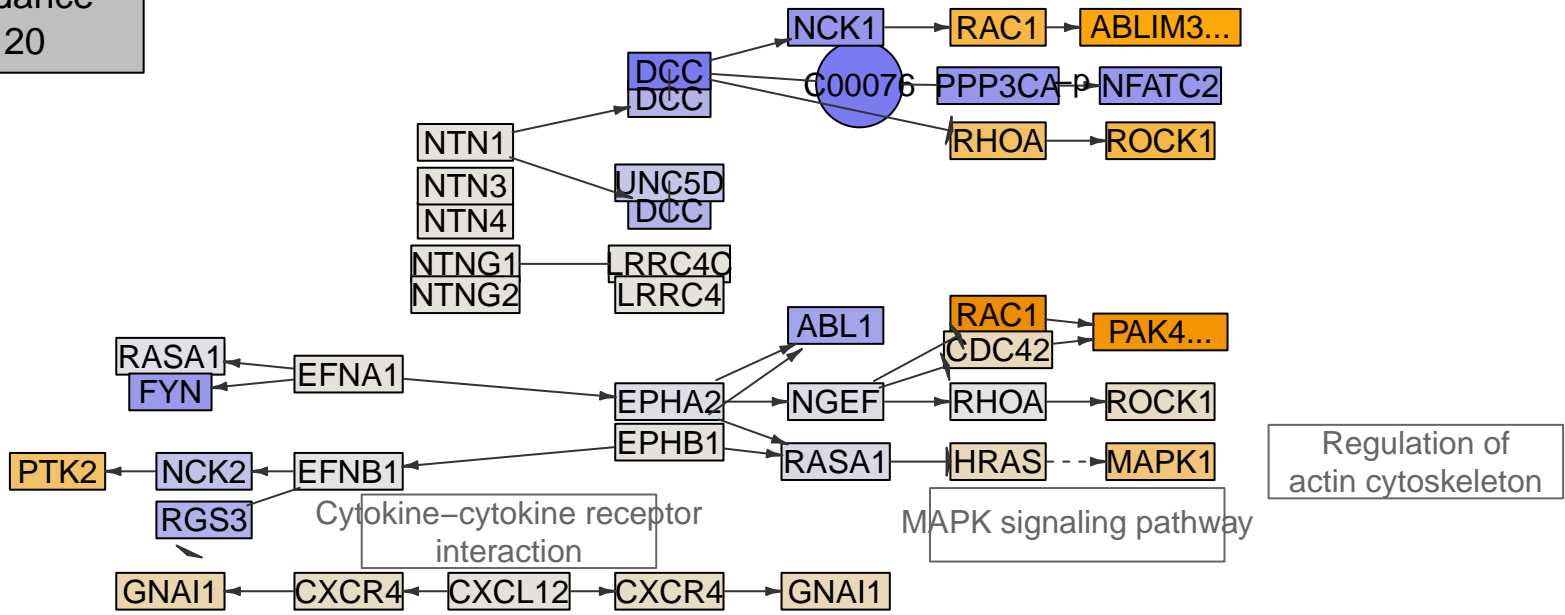

Regulation of actin cytoskeleton

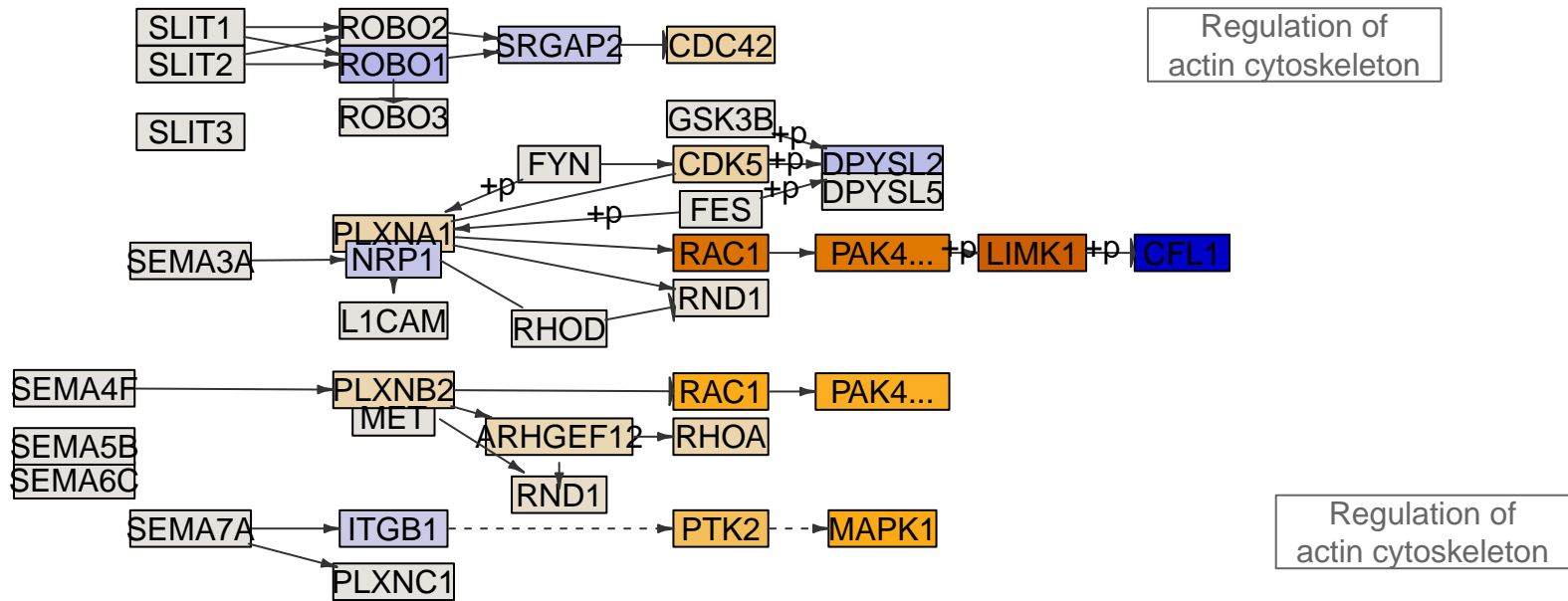

Regulation of actin cytoskeleton

Regulation of actin cytoskeleton

Axon guidance
MPI-121

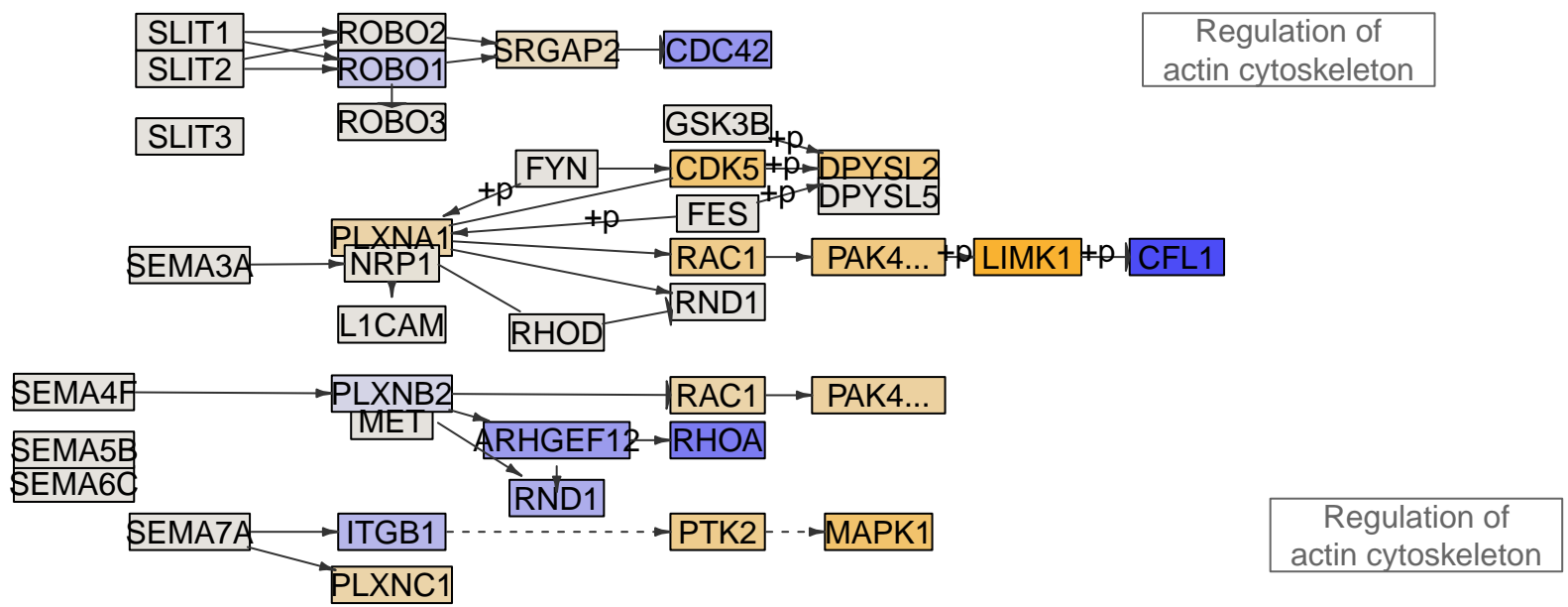
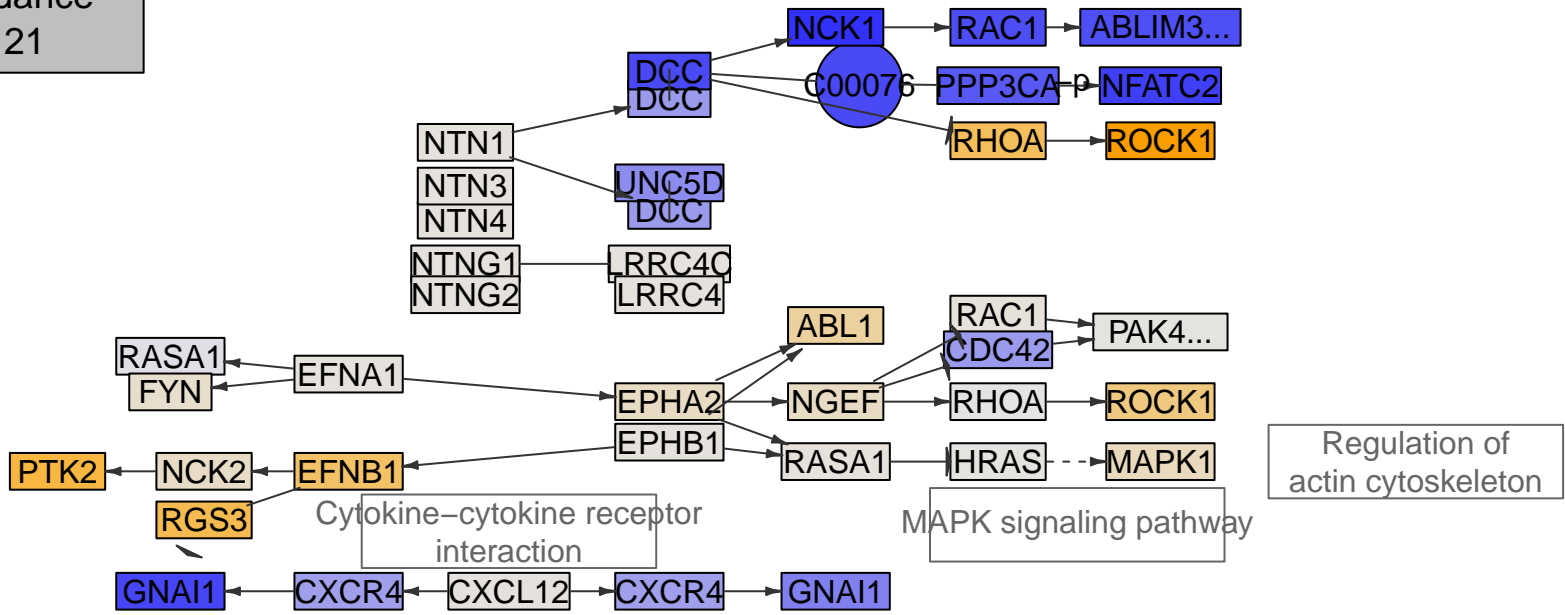

Axon guidance
MPI-124

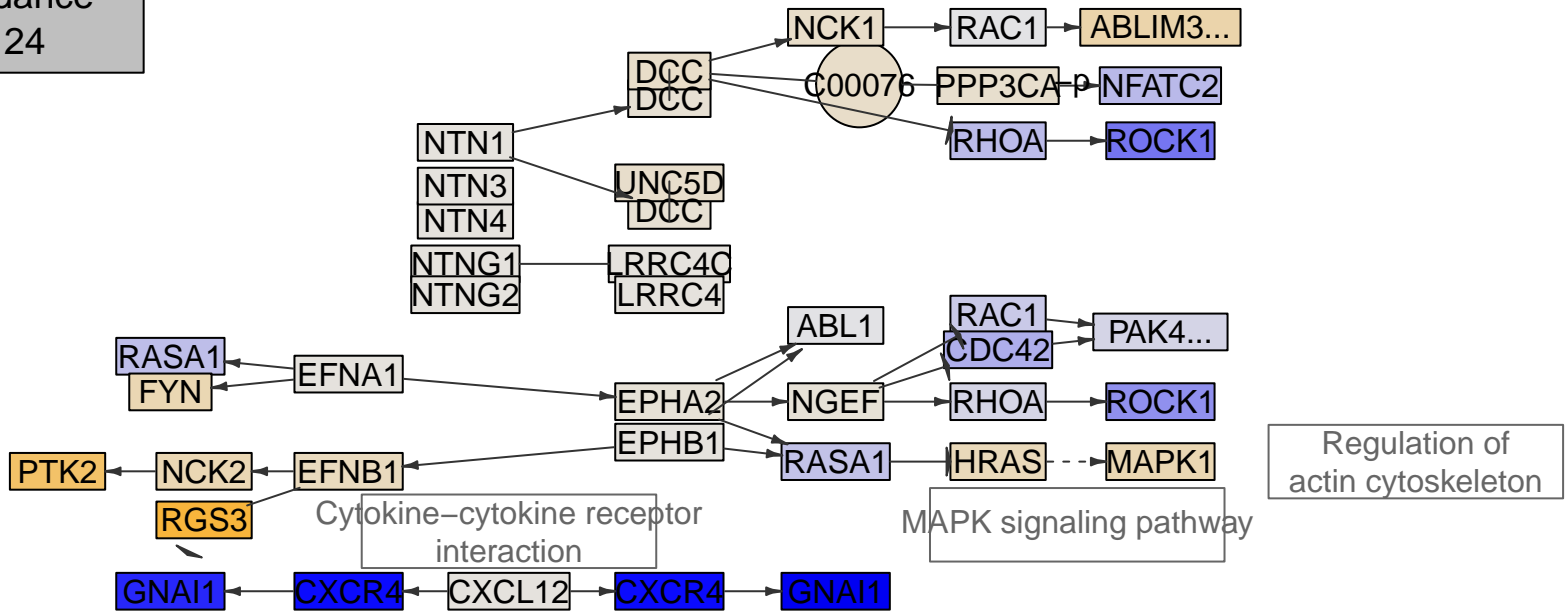

Regulation of actin cytoskeleton

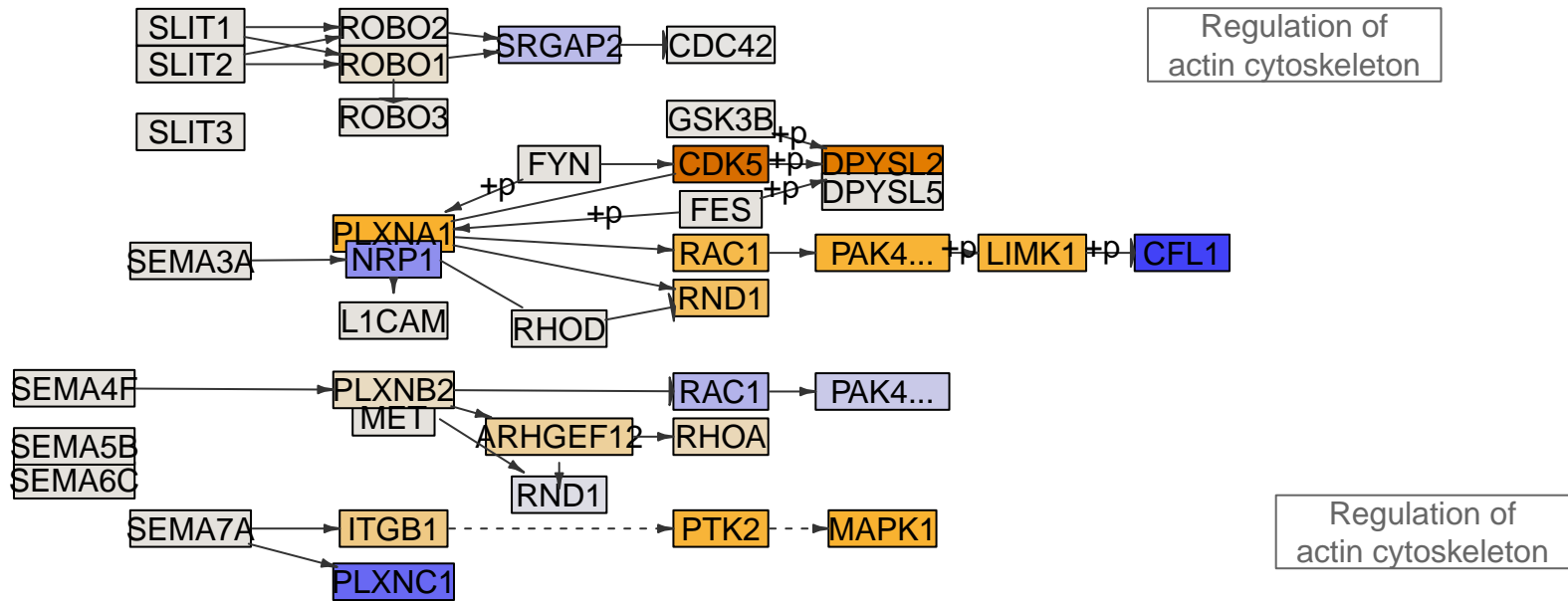

Regulation of actin cytoskeleton

Regulation of actin cytoskeleton

Axon guidance
MPI-126

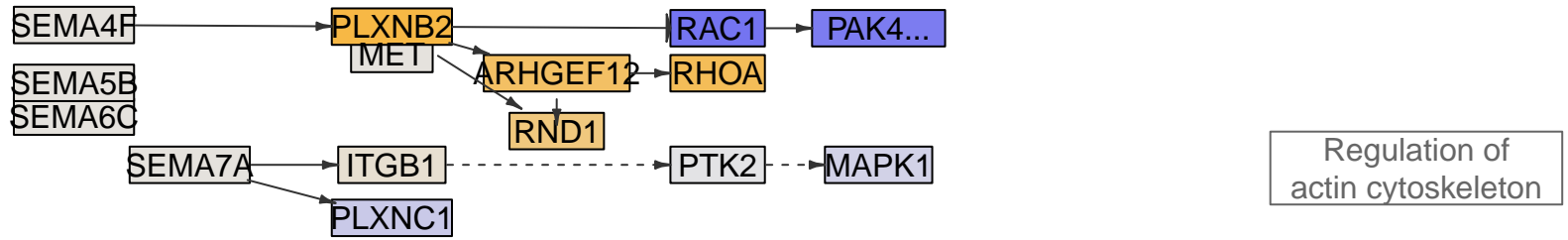
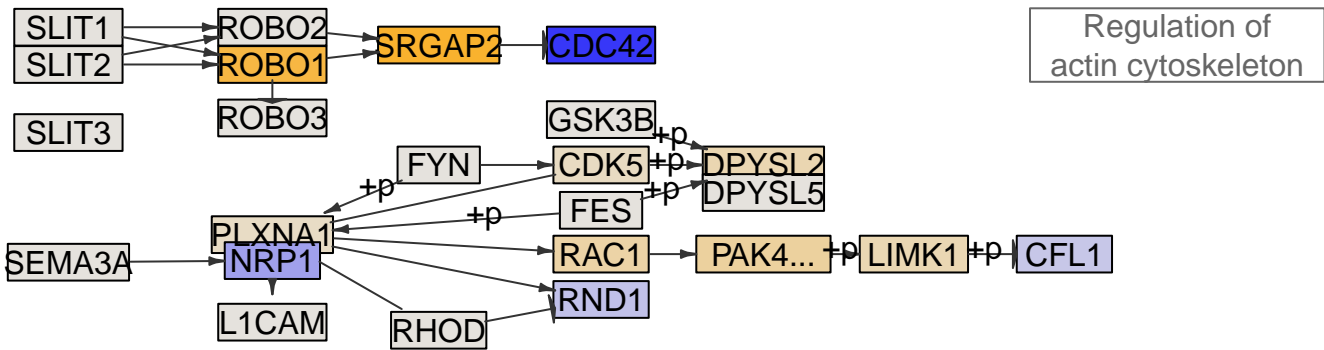
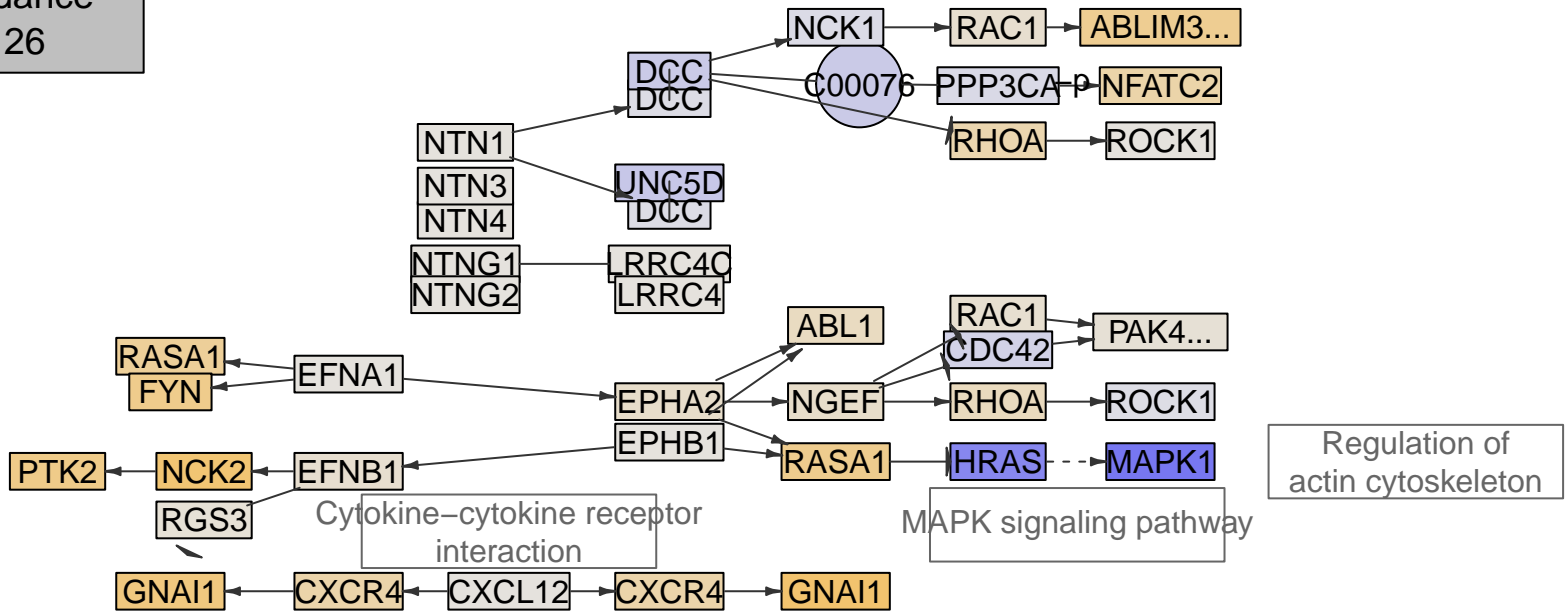

Axon guidance
MPI-131

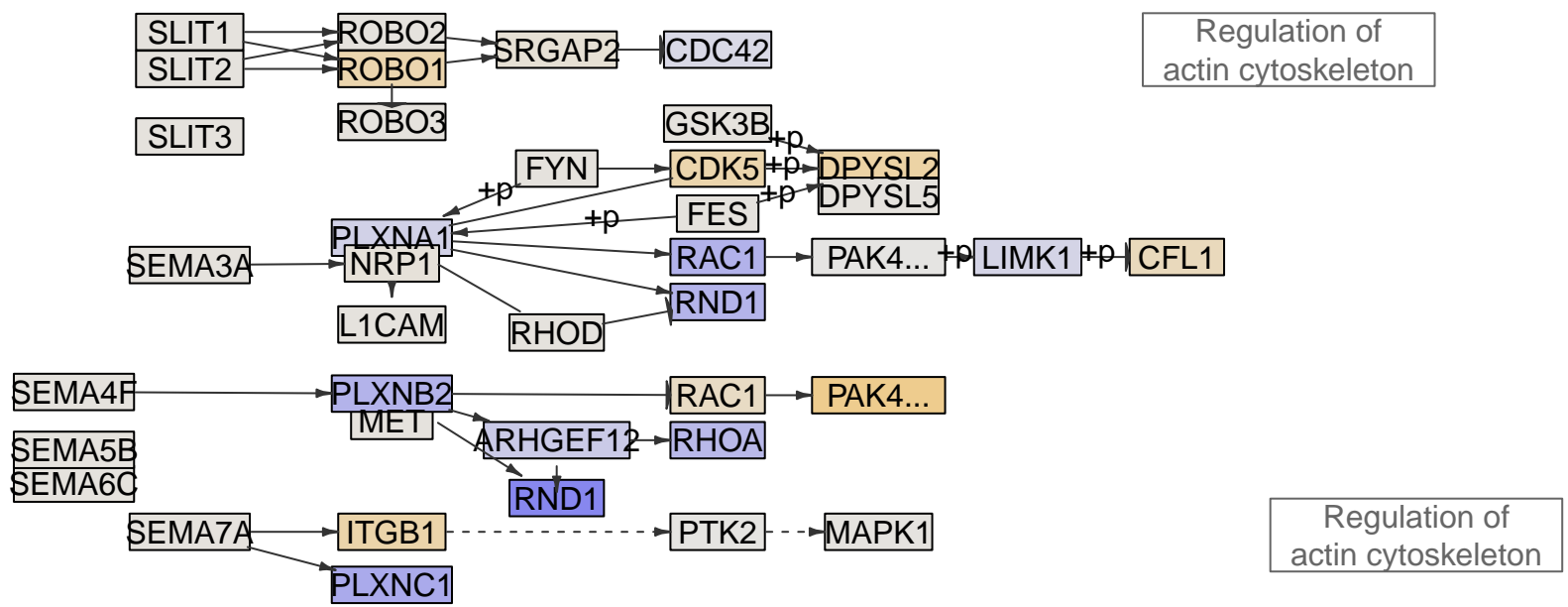
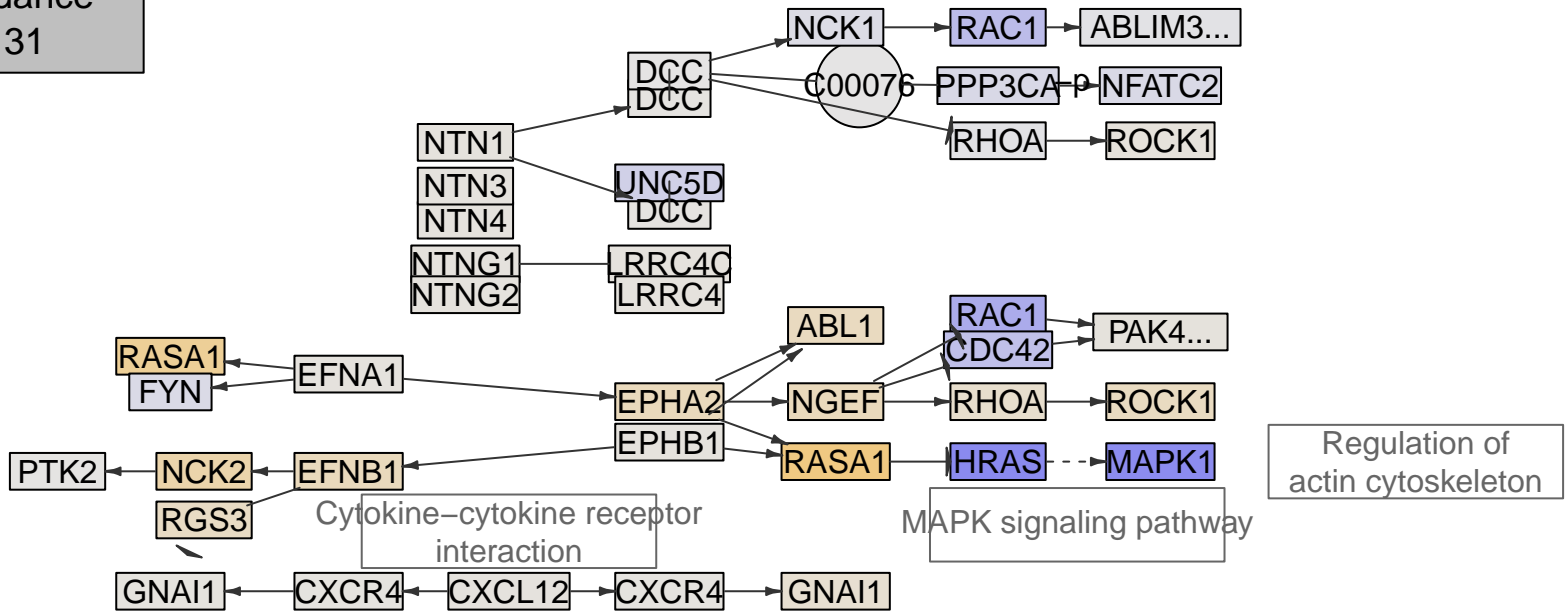

Axon guidance
MPI-143

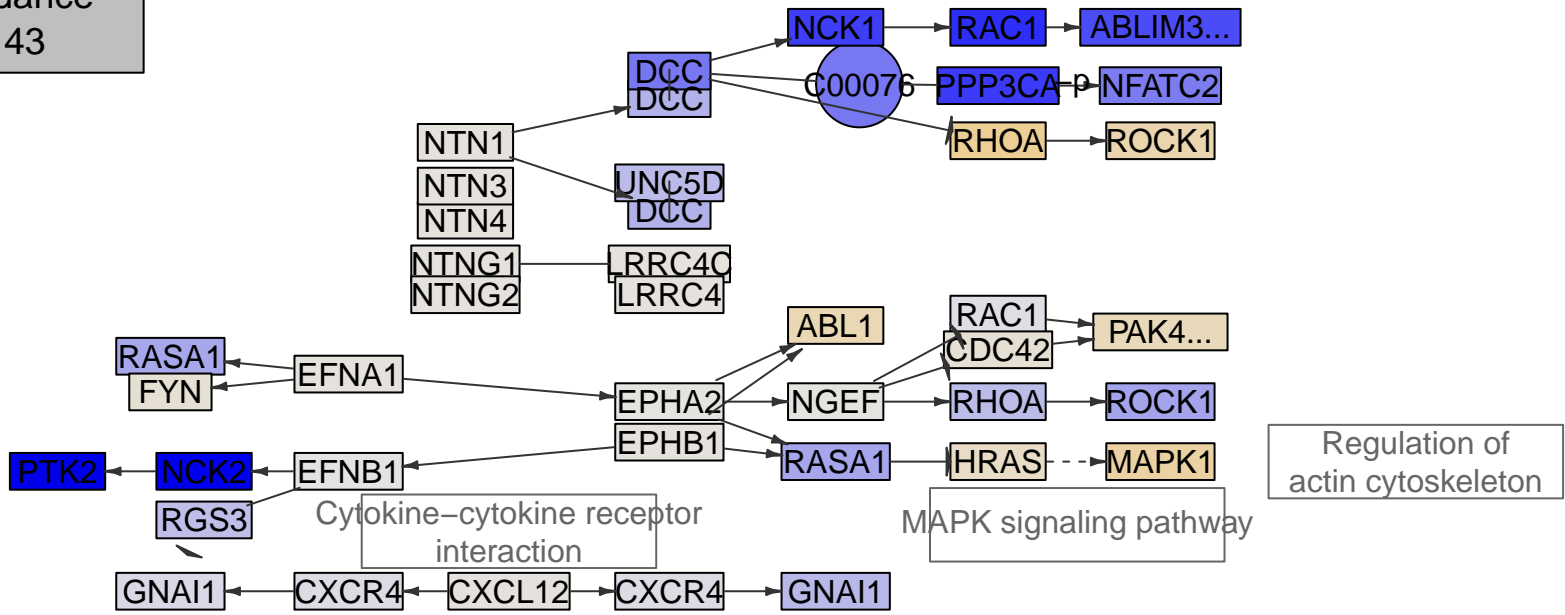

Regulation of actin cytoskeleton

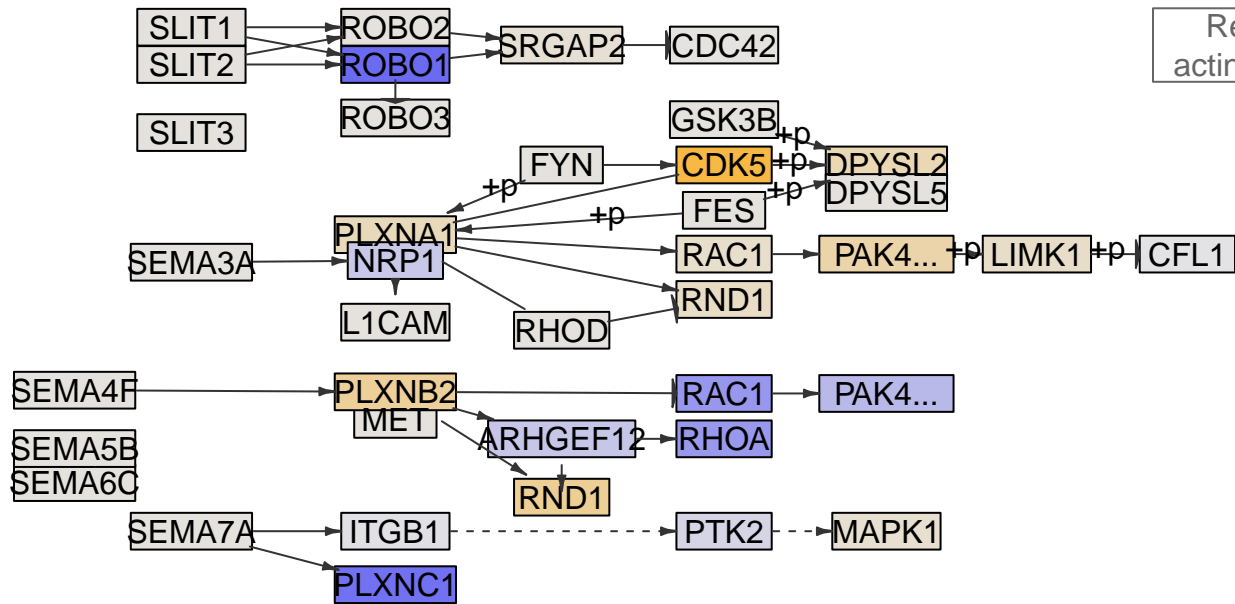

Regulation of actin cytoskeleton

Regulation of actin cytoskeleton

Axon guidance
MPI-148

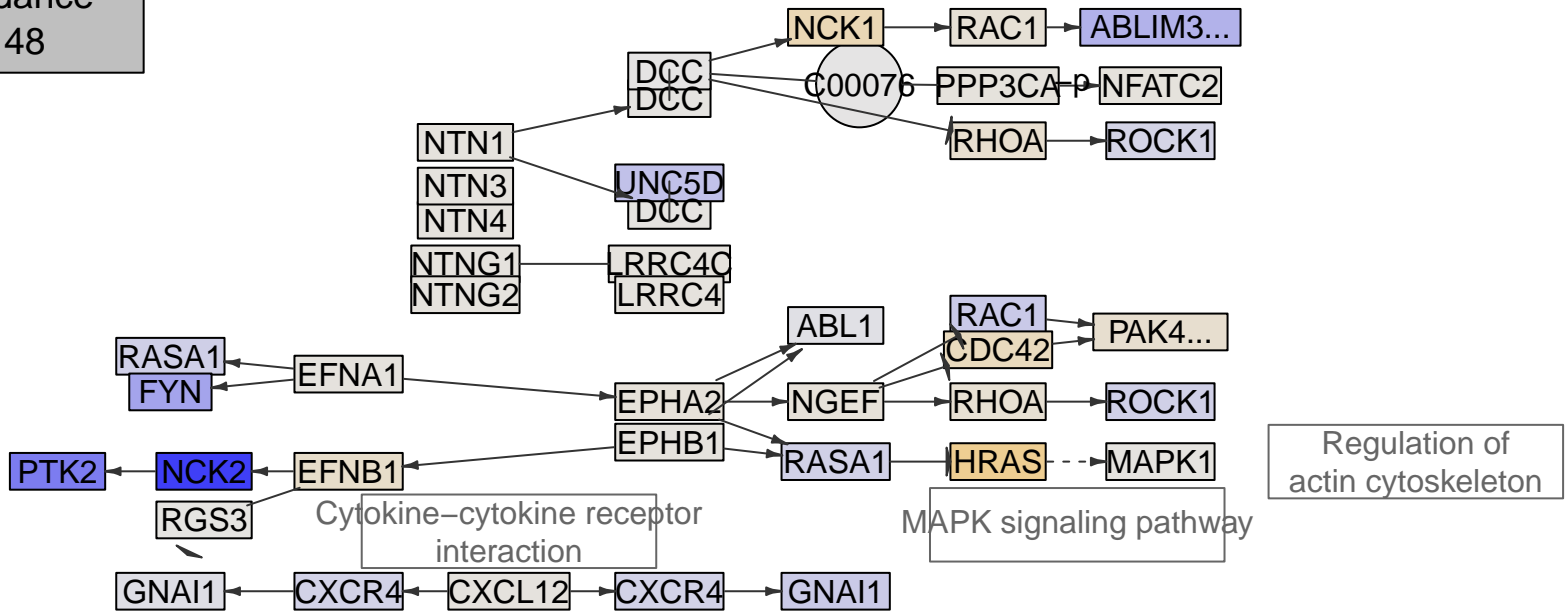

Regulation of actin cytoskeleton

MAPK signaling pathway

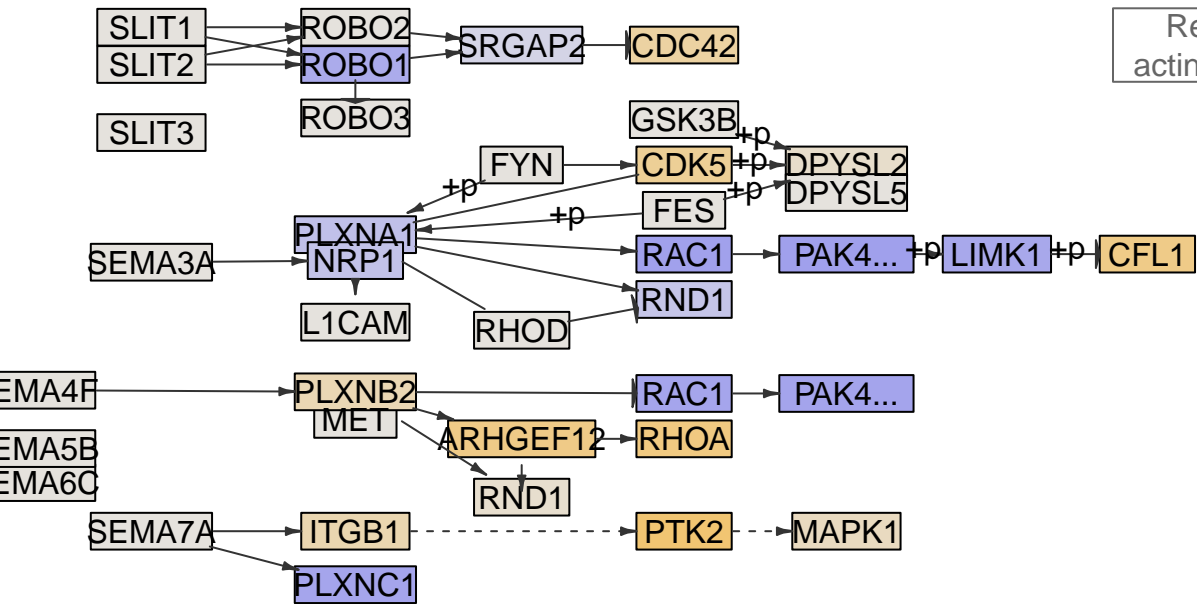

Regulation of actin cytoskeleton

Regulation of actin cytoskeleton

Axon guidance
MPI-161

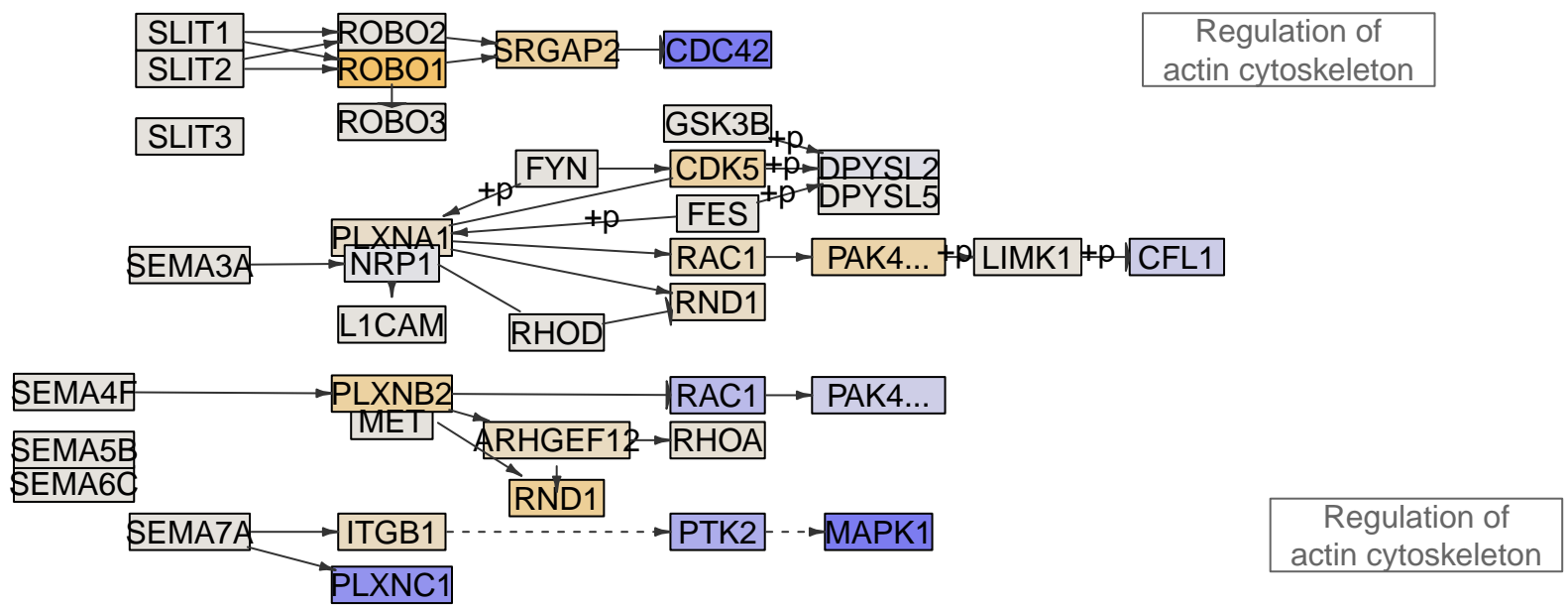
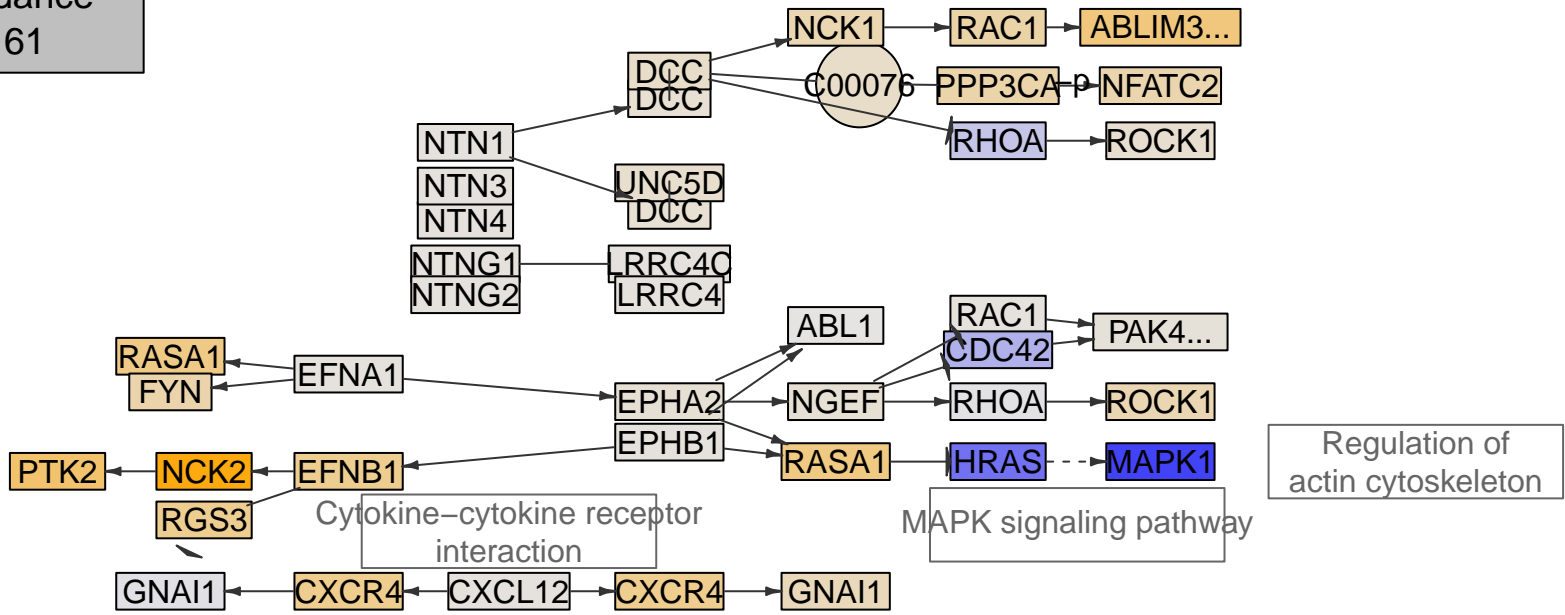

Axon guidance
MPI-162

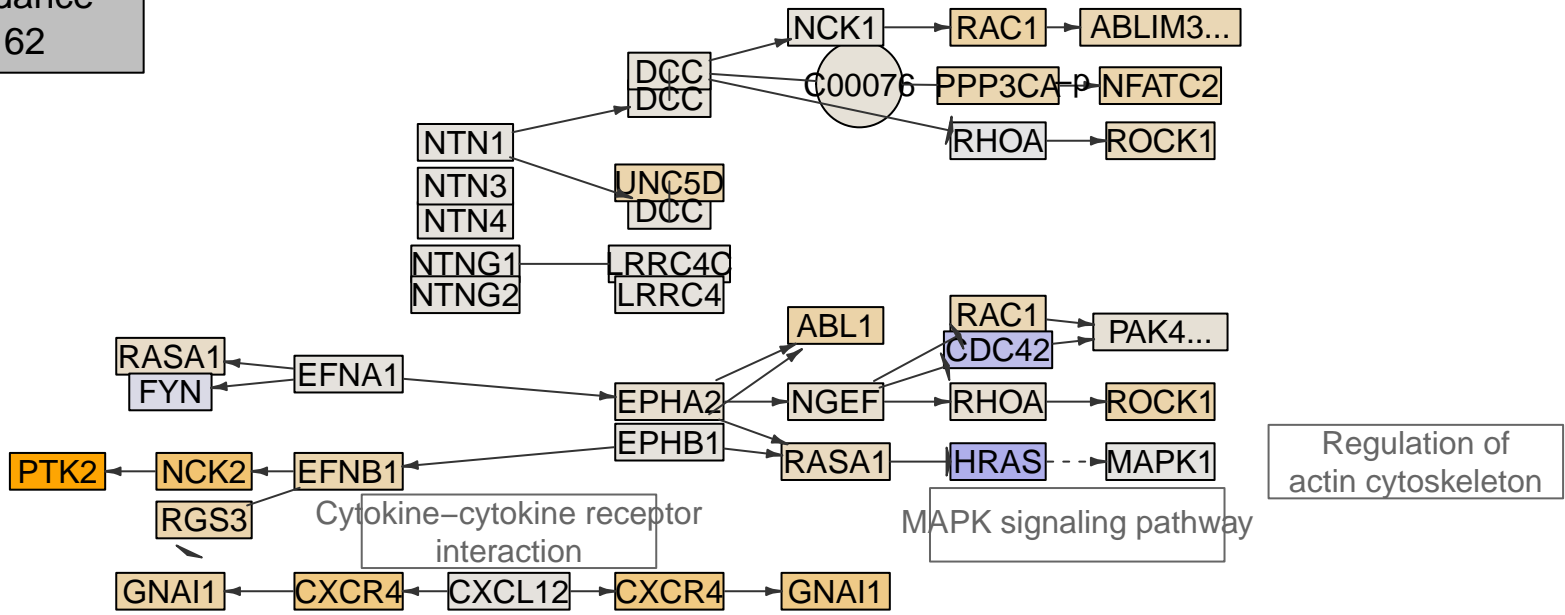

Regulation of actin cytoskeleton

MAPK signaling pathway

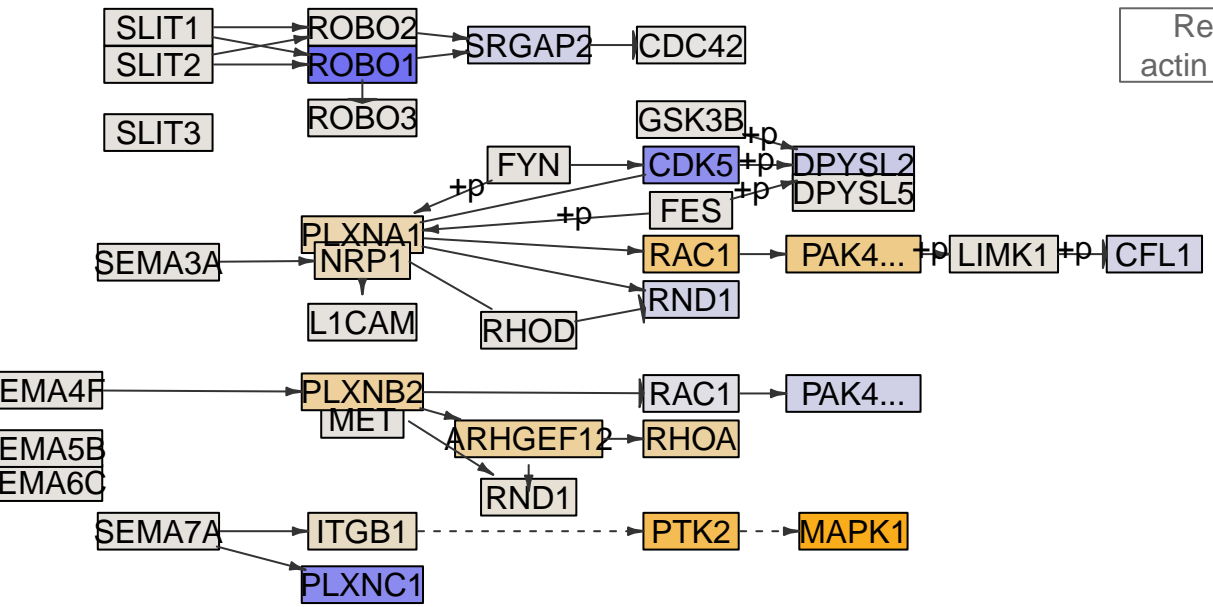

Regulation of actin cytoskeleton

Regulation of actin cytoskeleton

Axon guidance
MPI-165

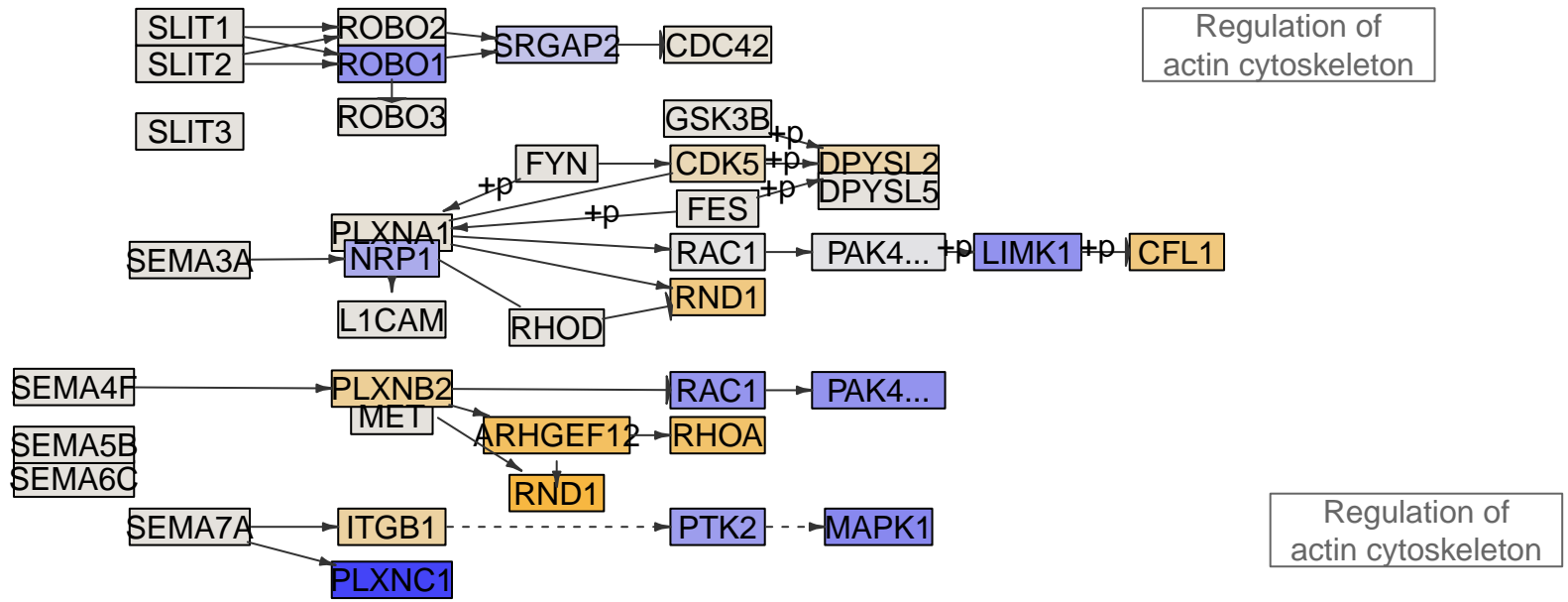
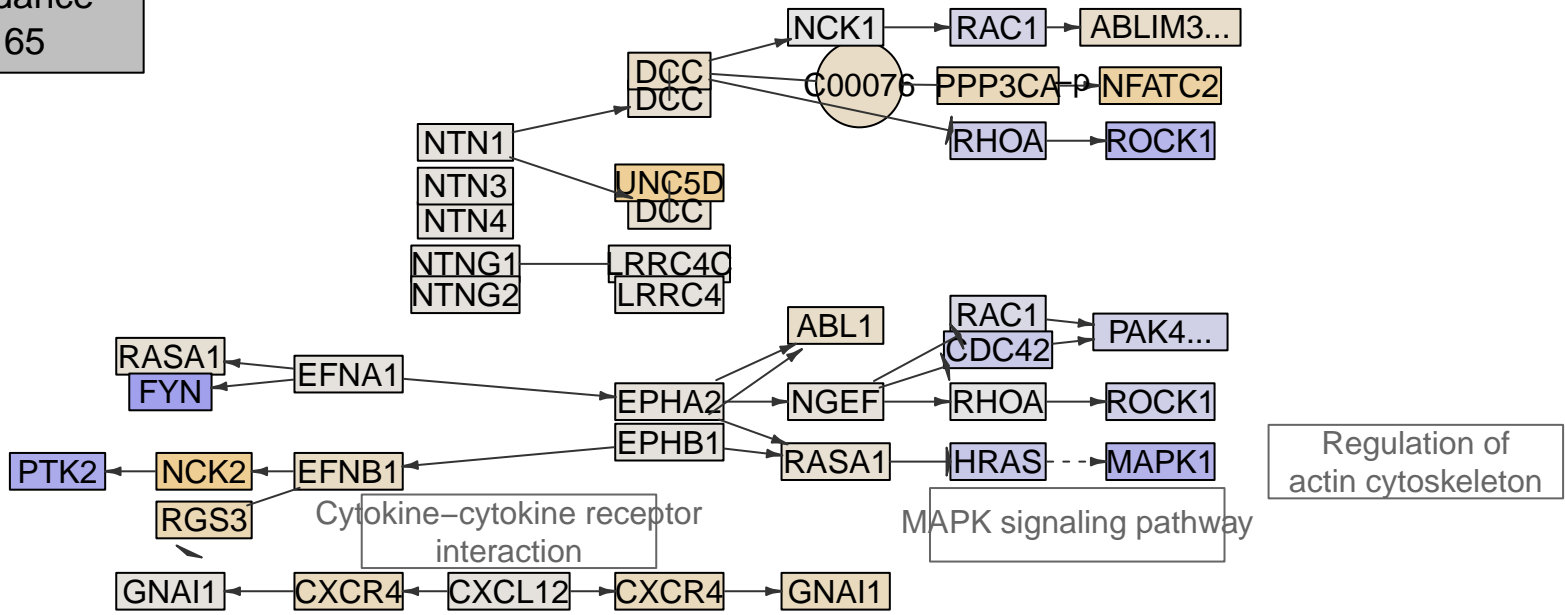

Axon guidance
MPI-169

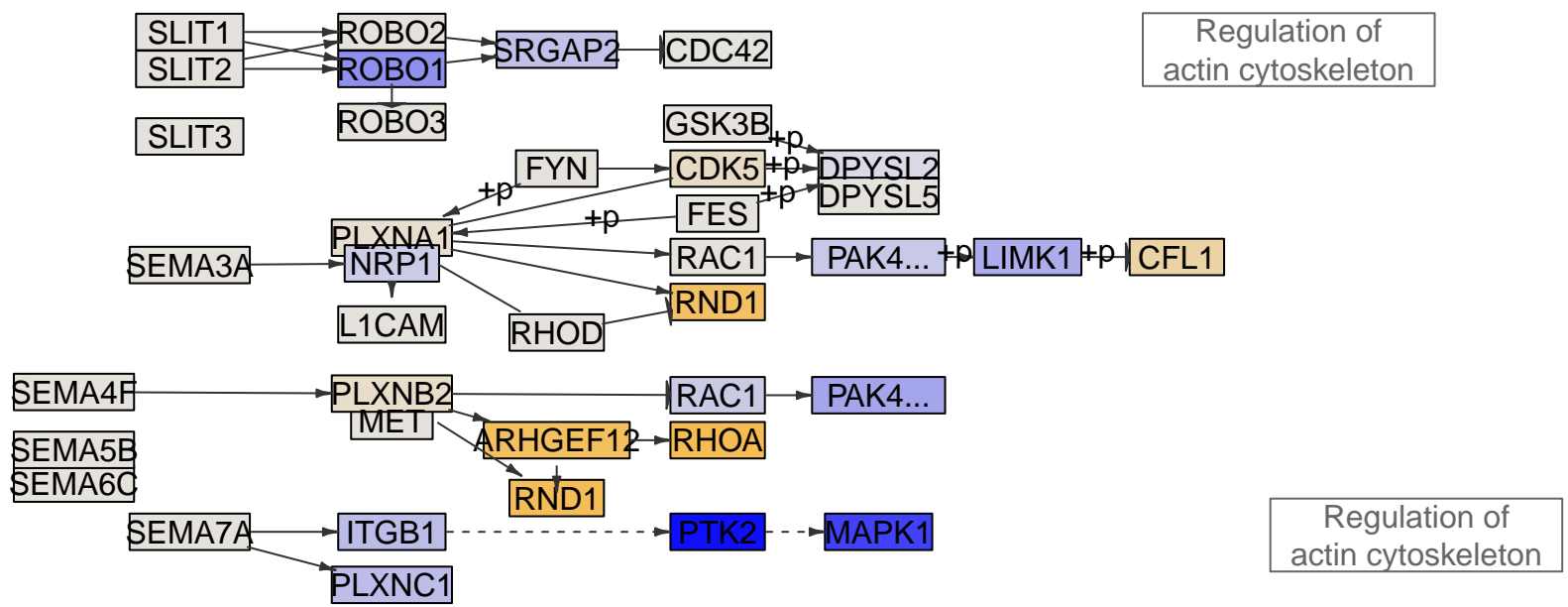
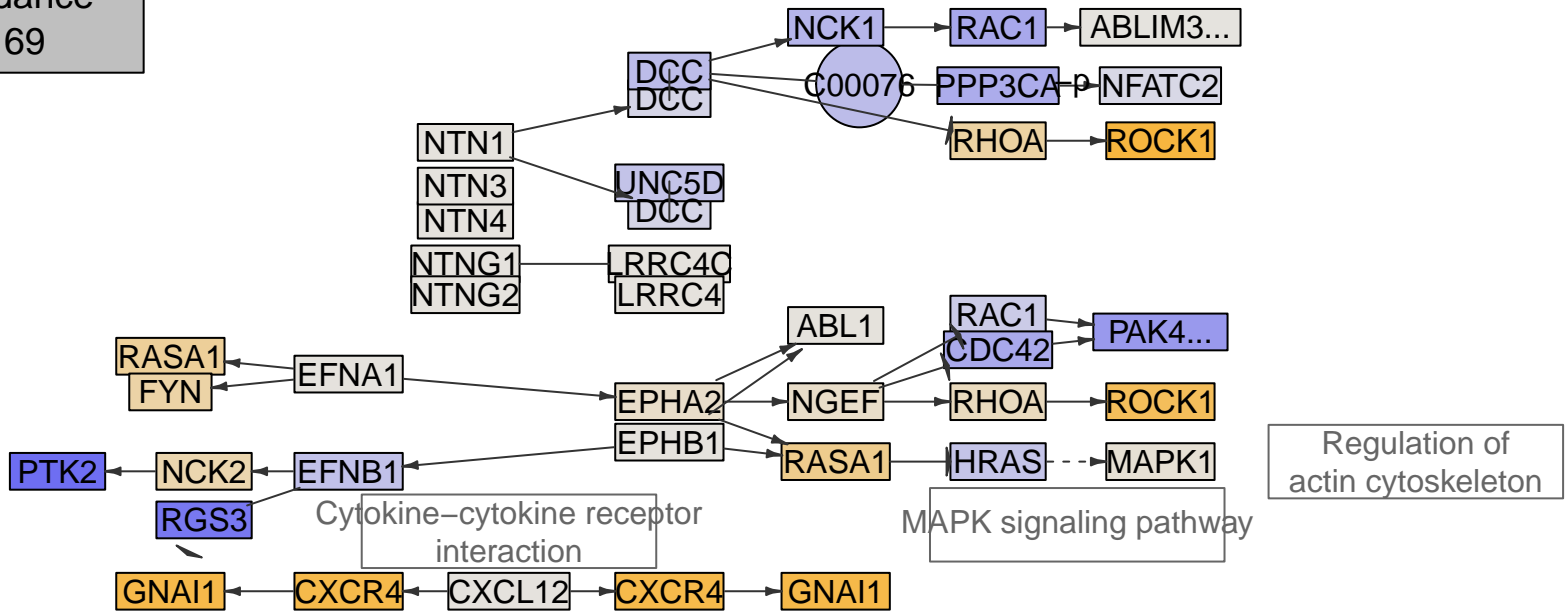

Axon guidance
MPI-175

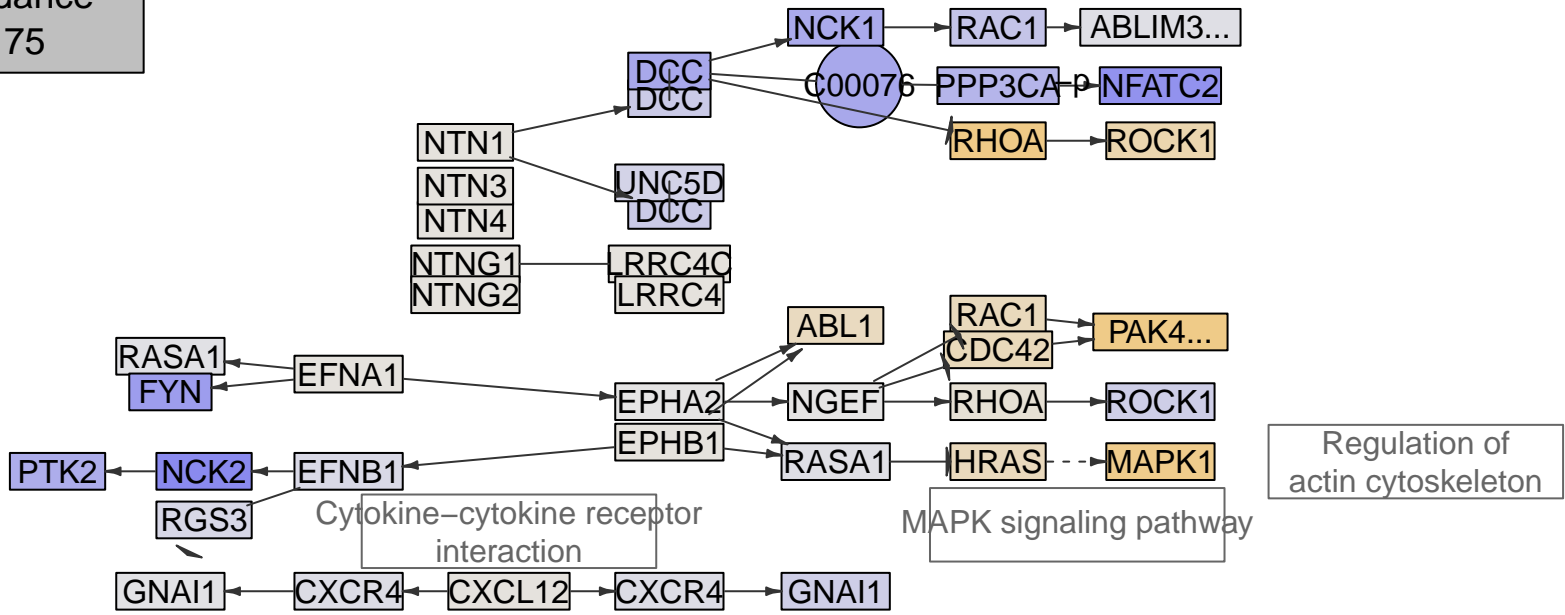

Regulation of actin cytoskeleton

MAPK signaling pathway

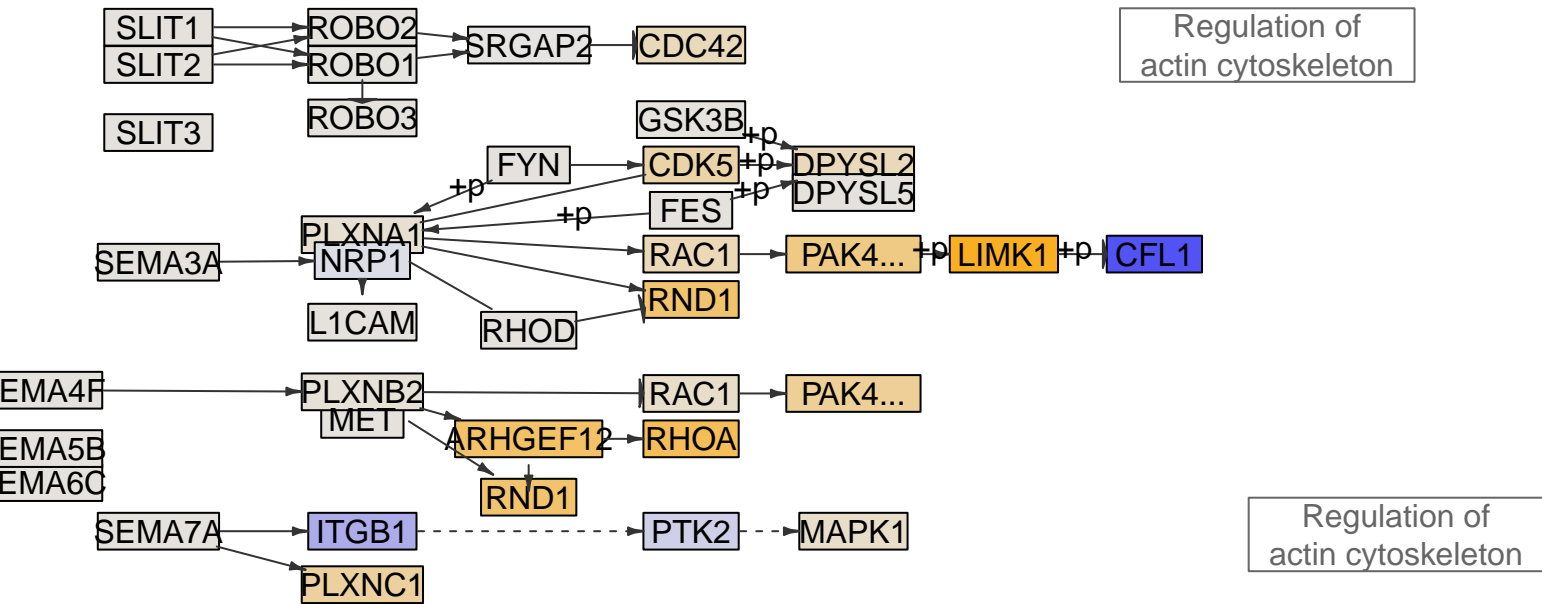

Regulation of actin cytoskeleton

Regulation of actin cytoskeleton

Axon guidance
MPI-187

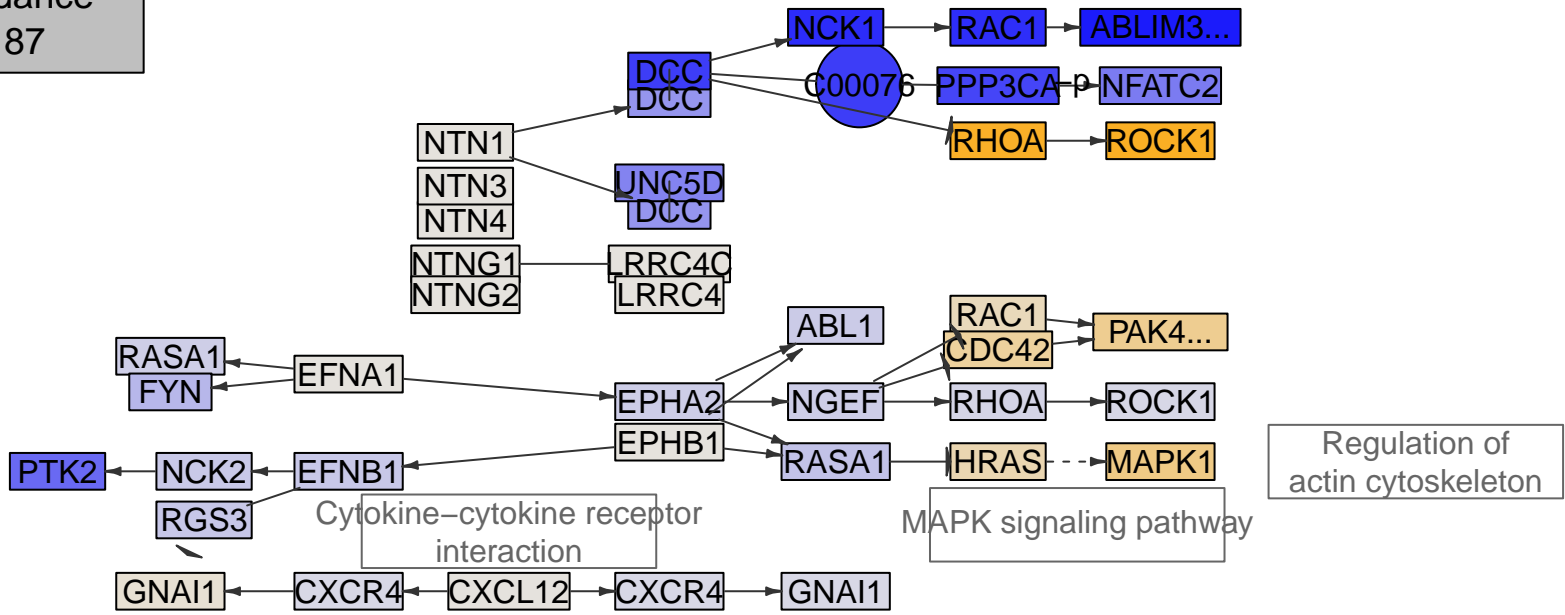

Regulation of actin cytoskeleton

MAPK signaling pathway

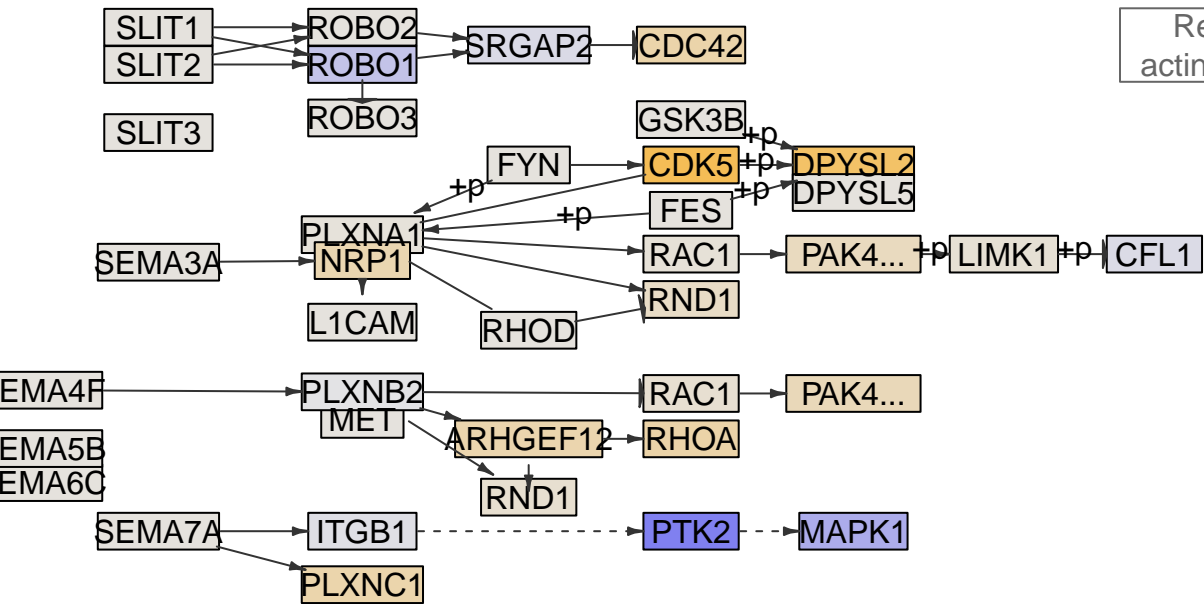

Regulation of actin cytoskeleton

Regulation of actin cytoskeleton

Axon guidance
MPI-193

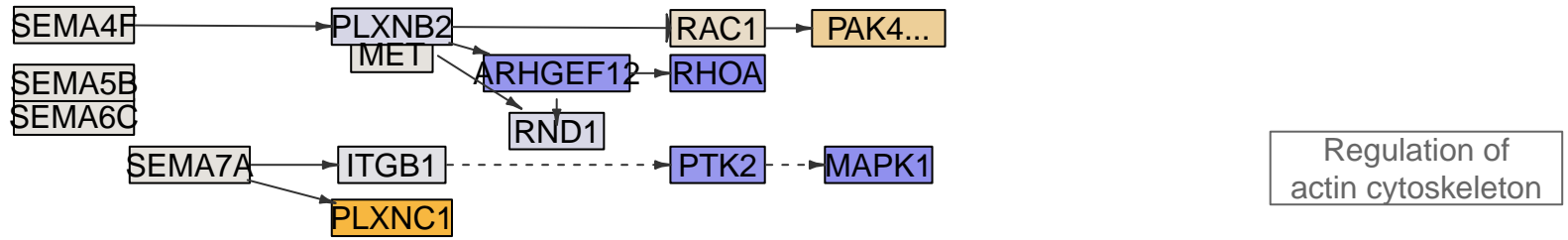
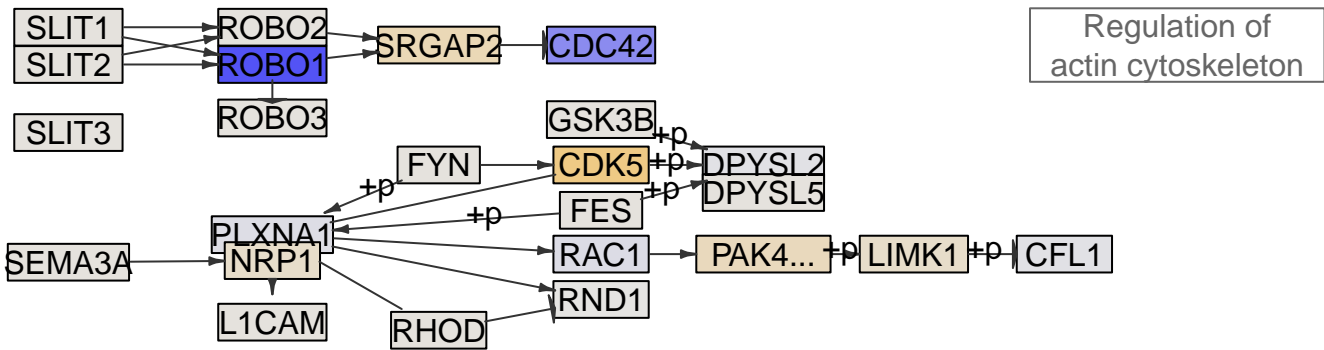
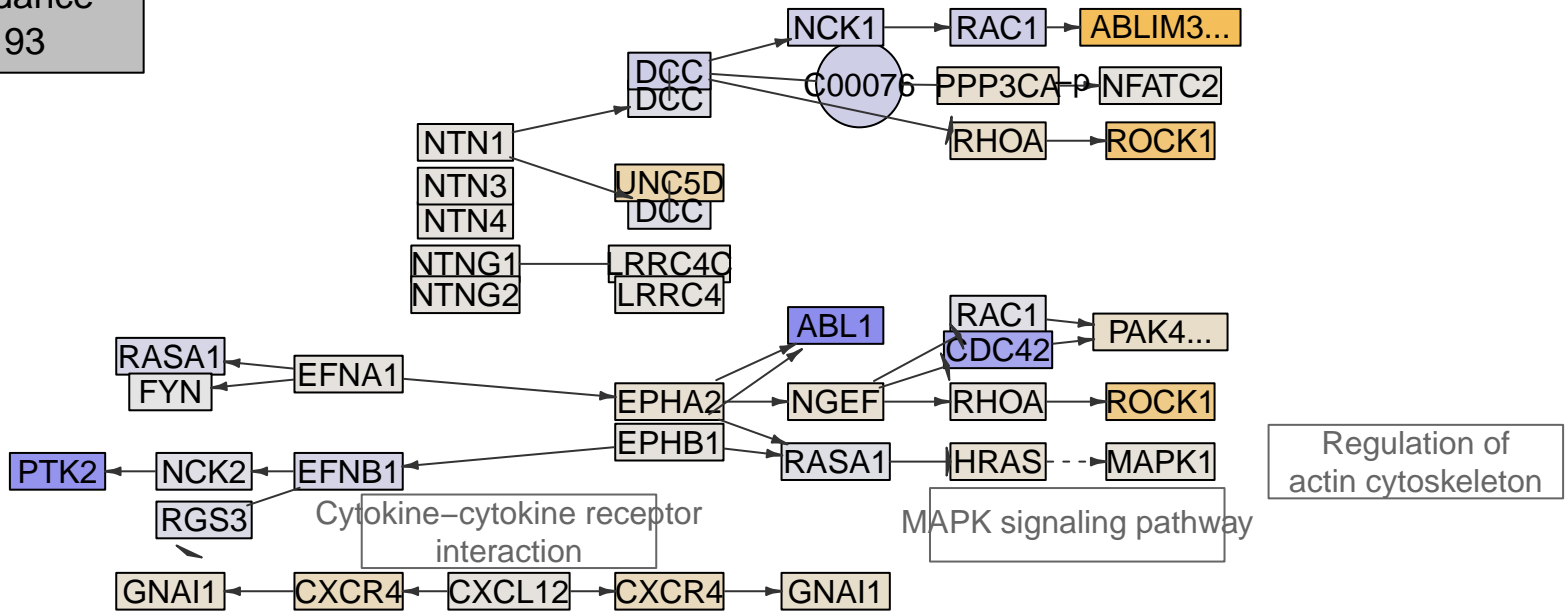

Axon guidance
MPI-216

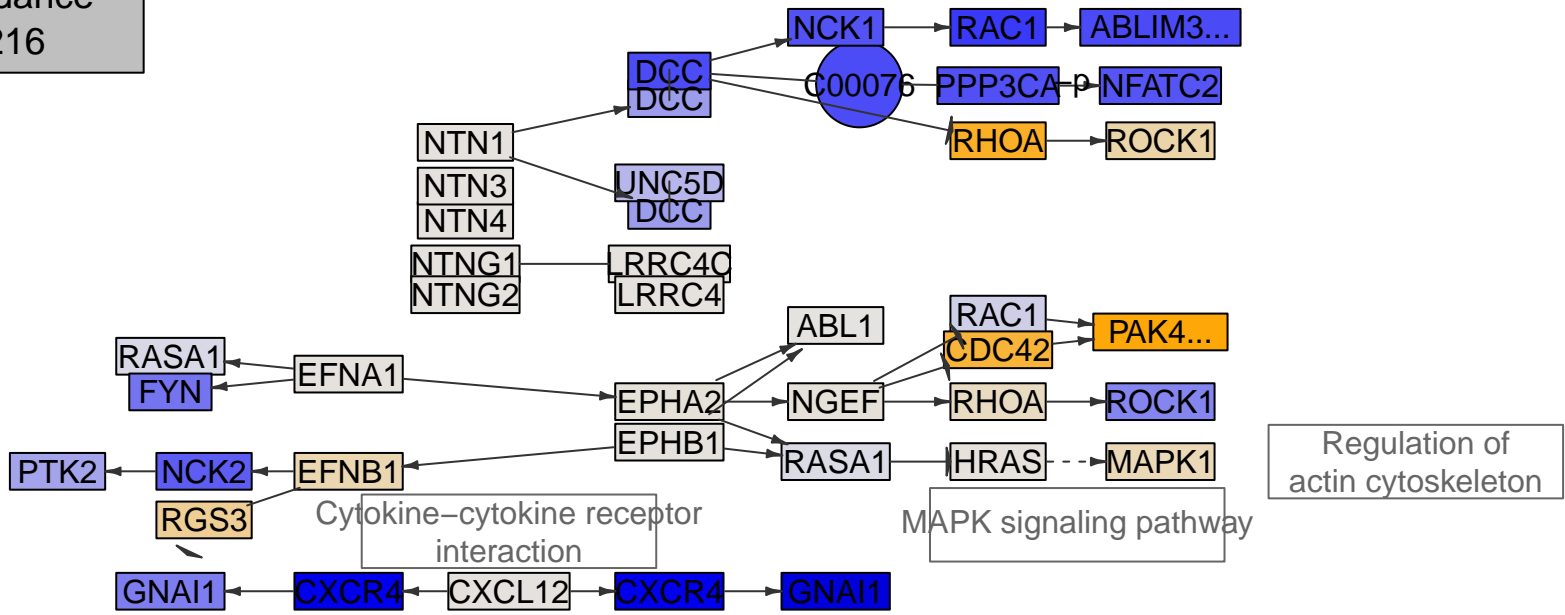

Regulation of actin cytoskeleton

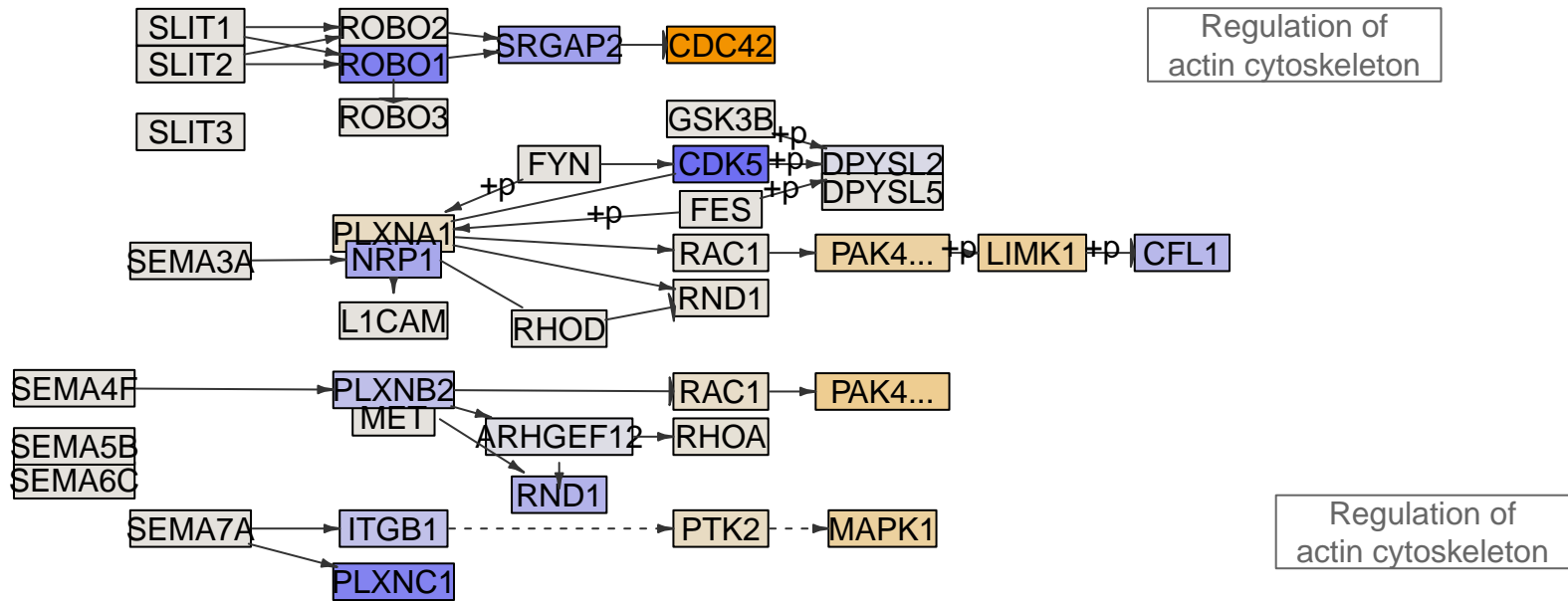

Regulation of actin cytoskeleton

Regulation of actin cytoskeleton

Axon guidance
MPI-222

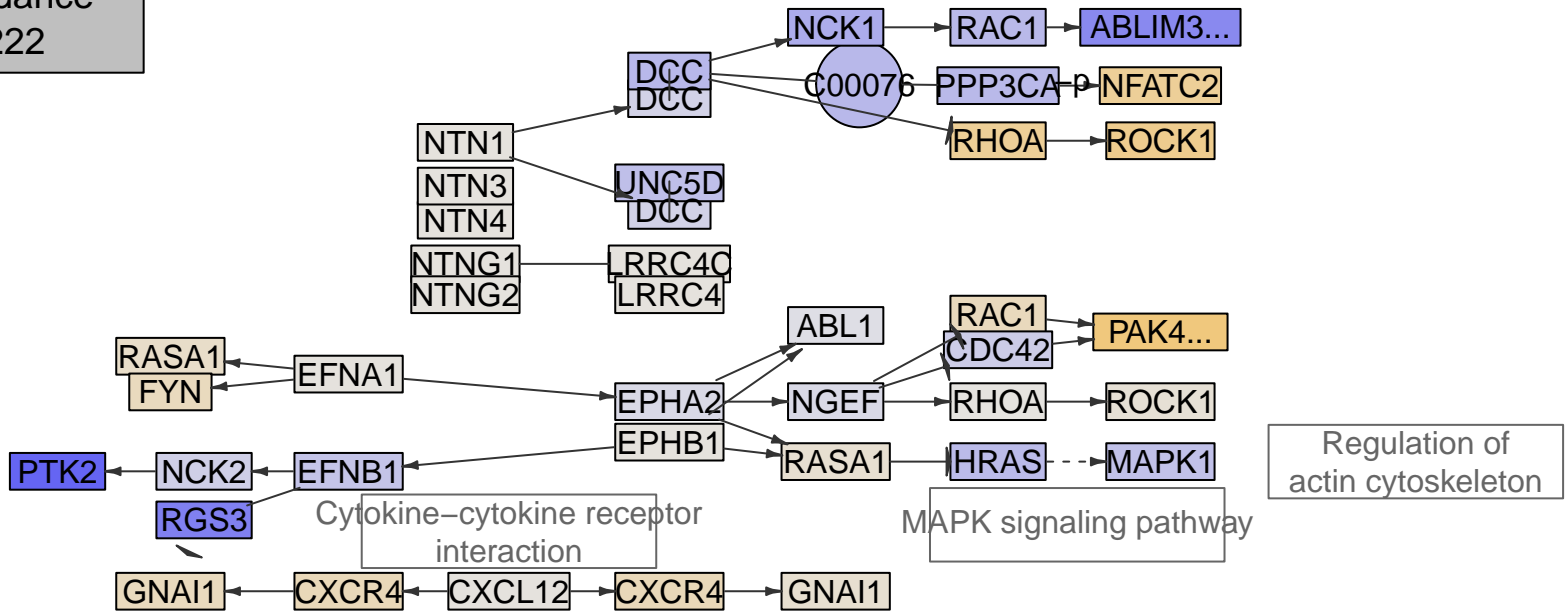

Regulation of actin cytoskeleton

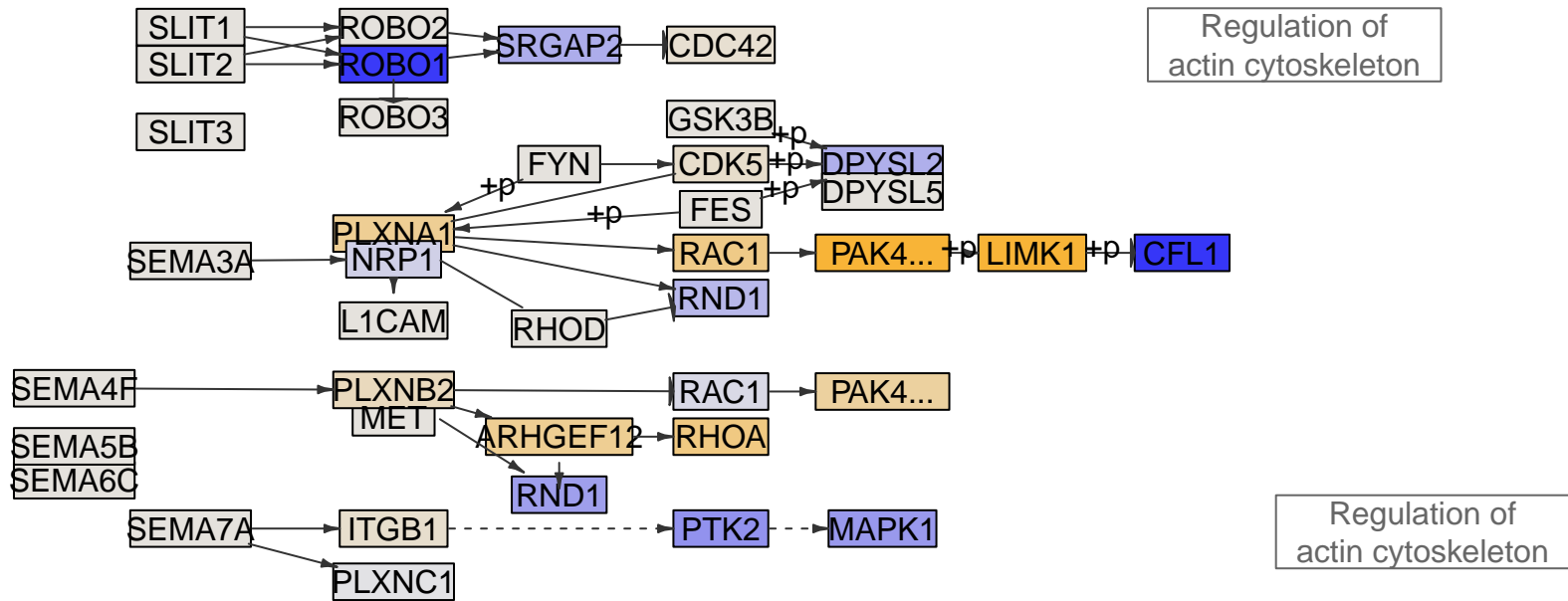

Regulation of actin cytoskeleton

Regulation of actin cytoskeleton

Axon guidance
MPI-225

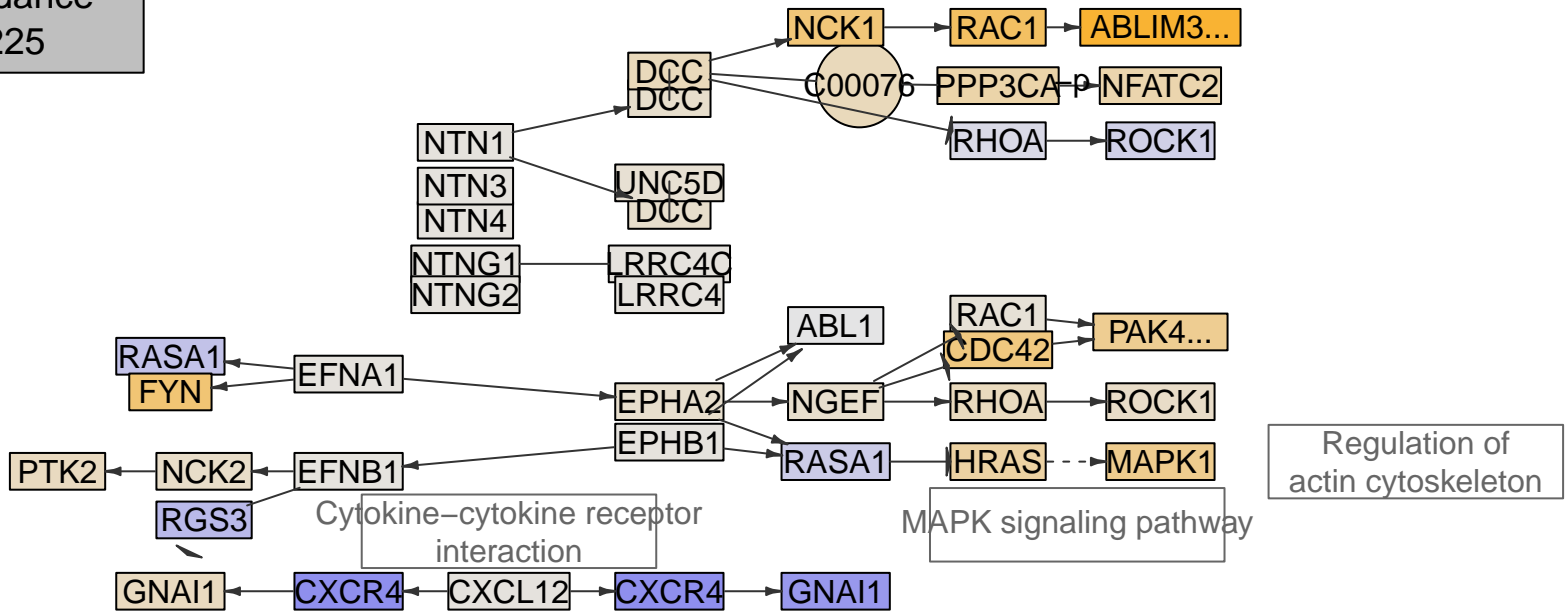

Regulation of actin cytoskeleton

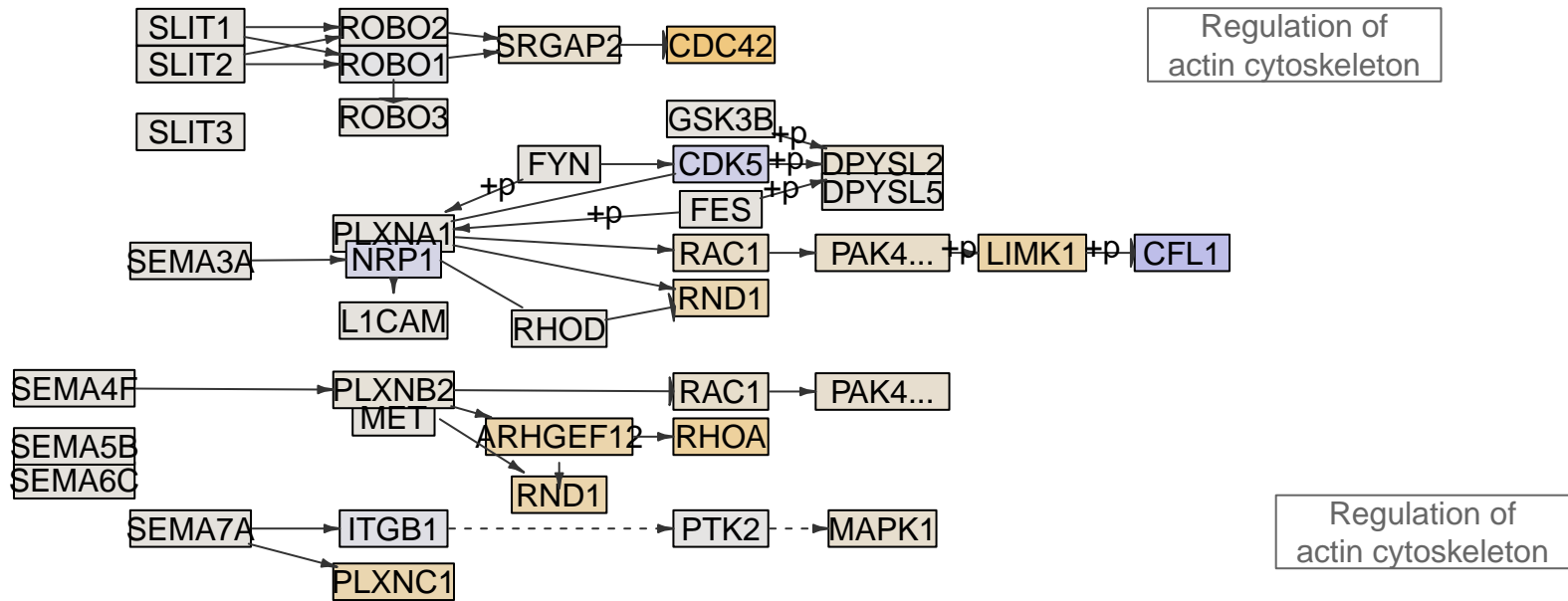

Regulation of actin cytoskeleton

Regulation of actin cytoskeleton

Axon guidance
MPI-242

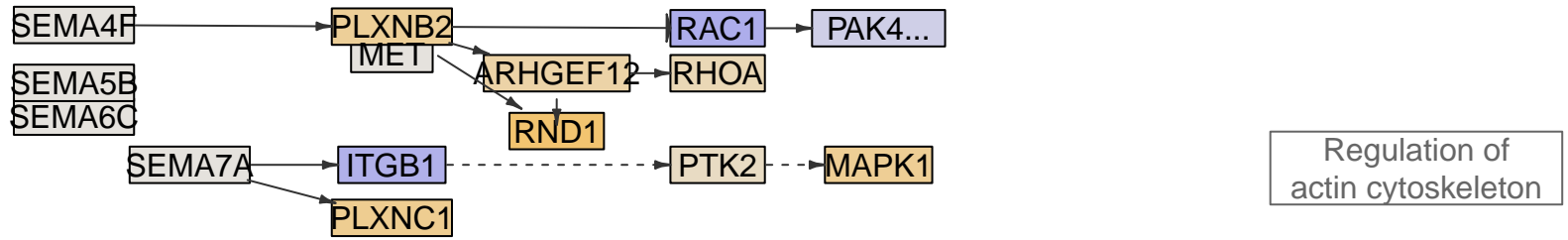
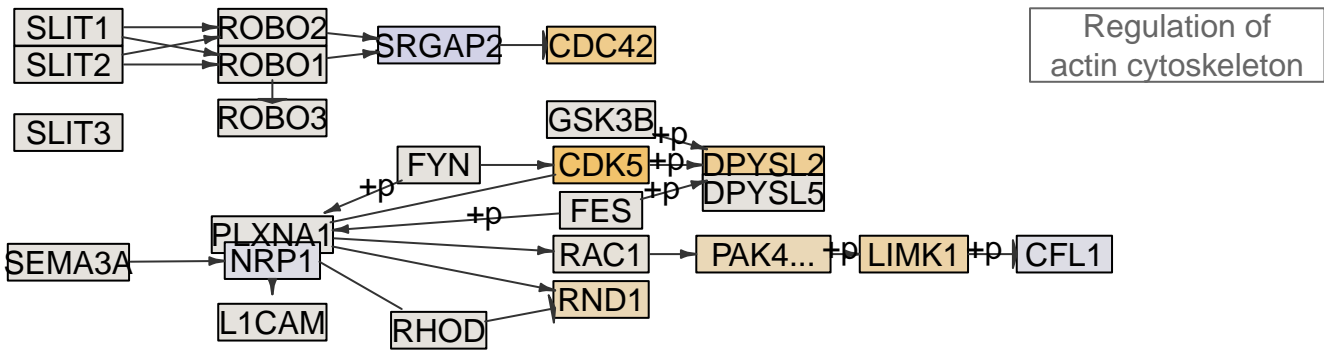
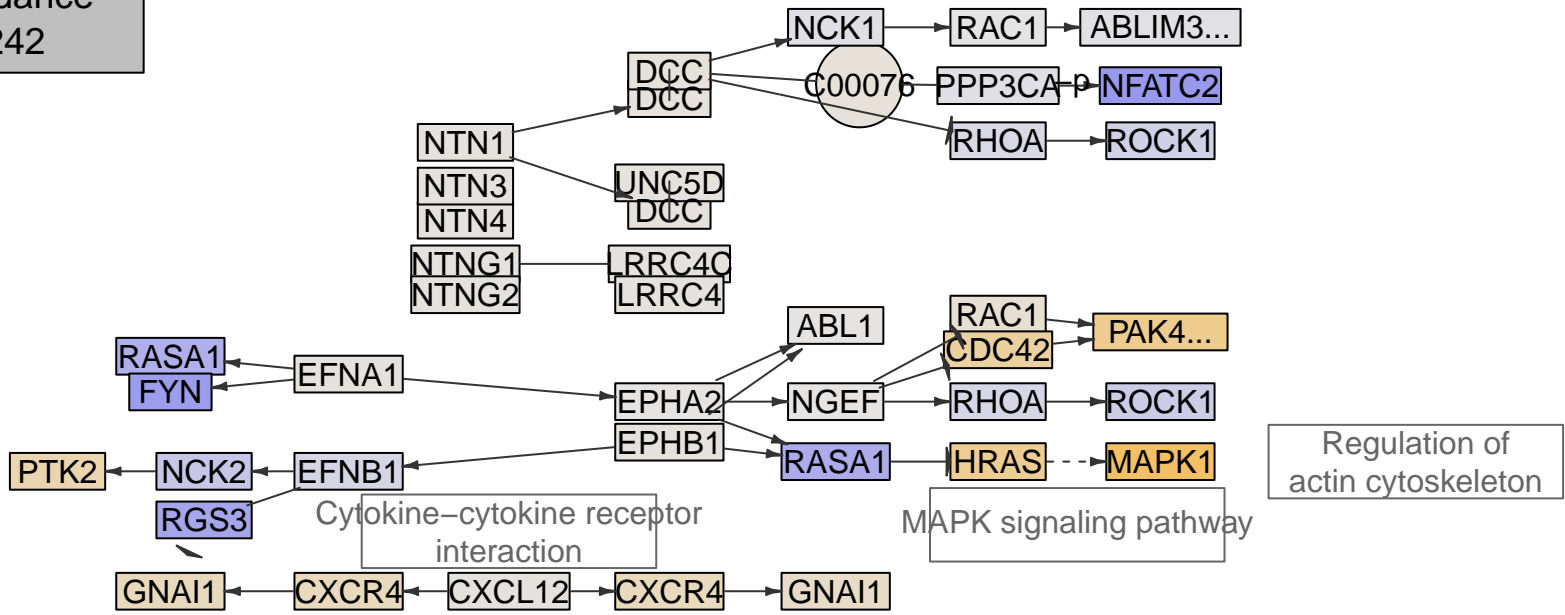

Axon guidance
MPI-245

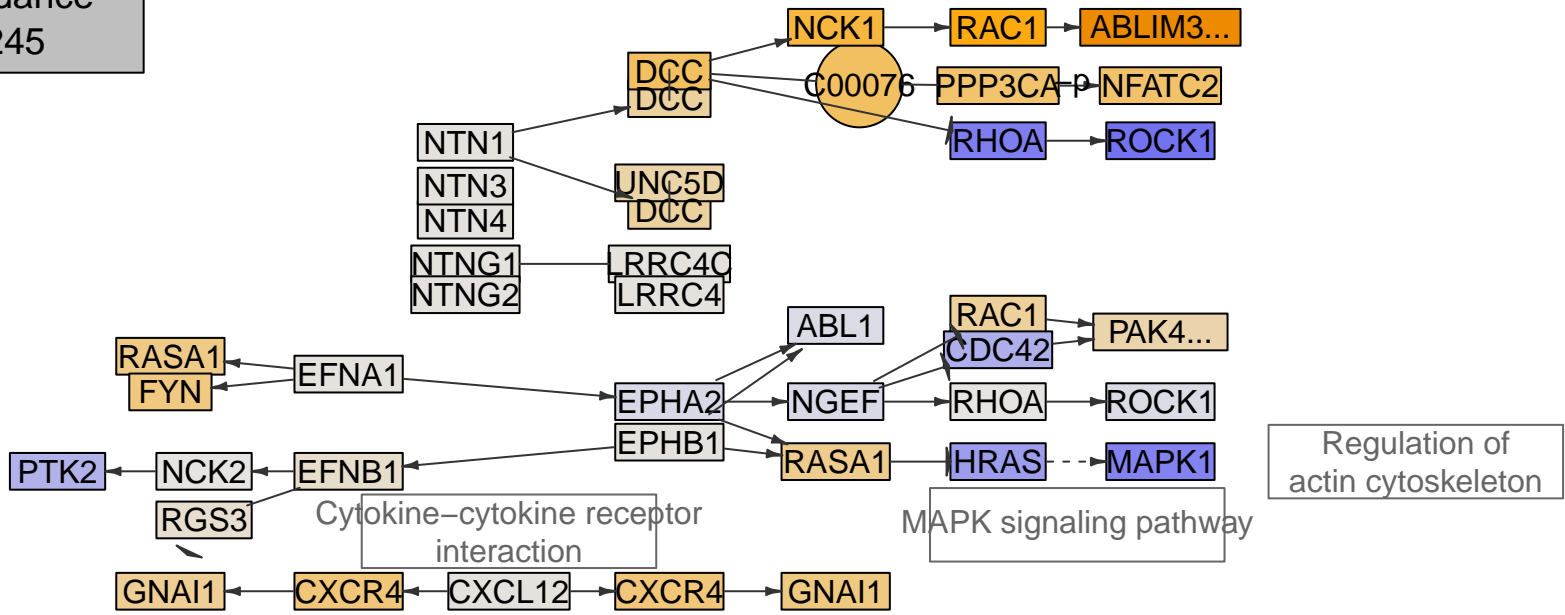

Regulation of actin cytoskeleton

MAPK signaling pathway

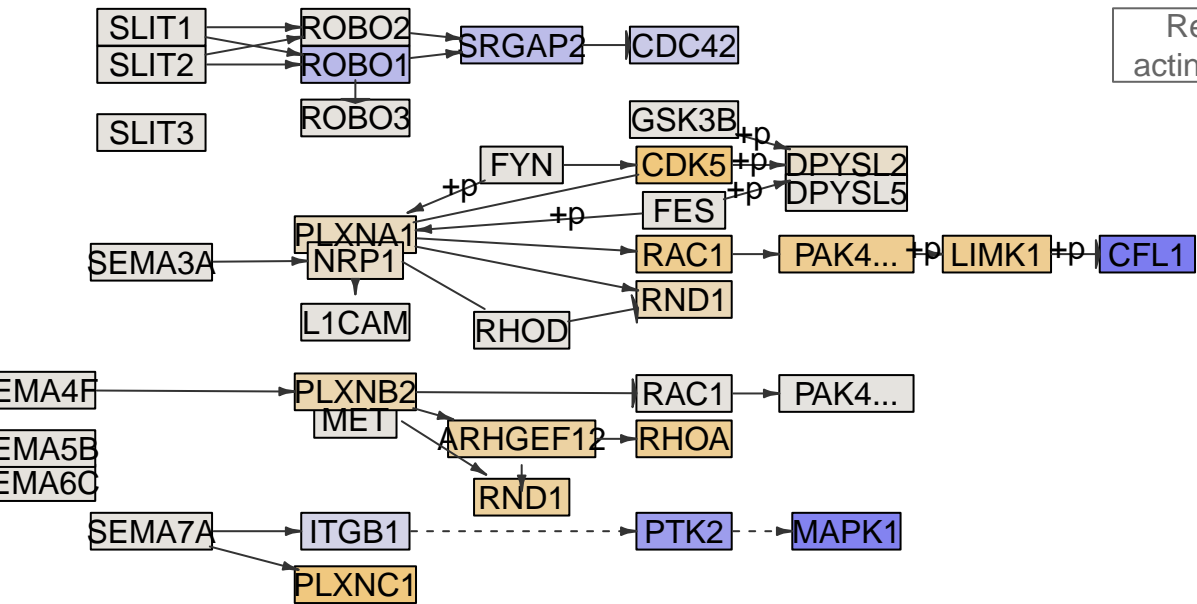

Regulation of actin cytoskeleton

Regulation of actin cytoskeleton

Axon guidance
MPI-248

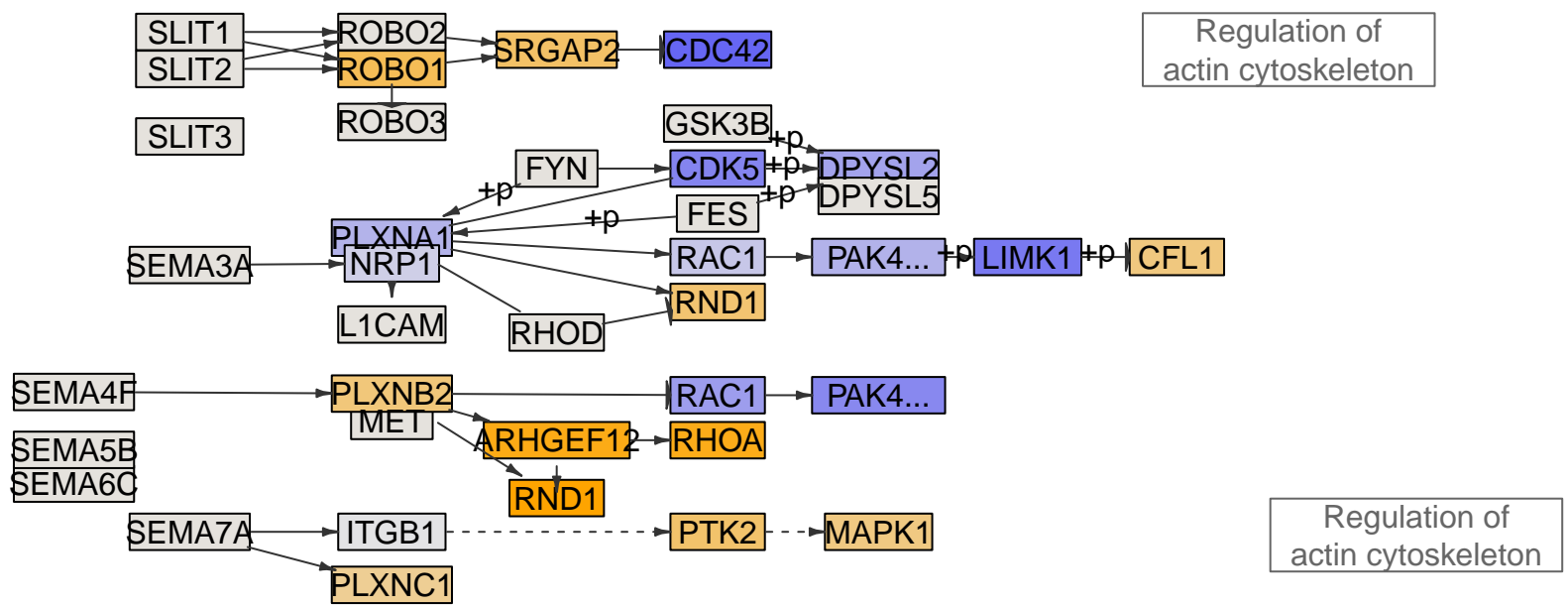
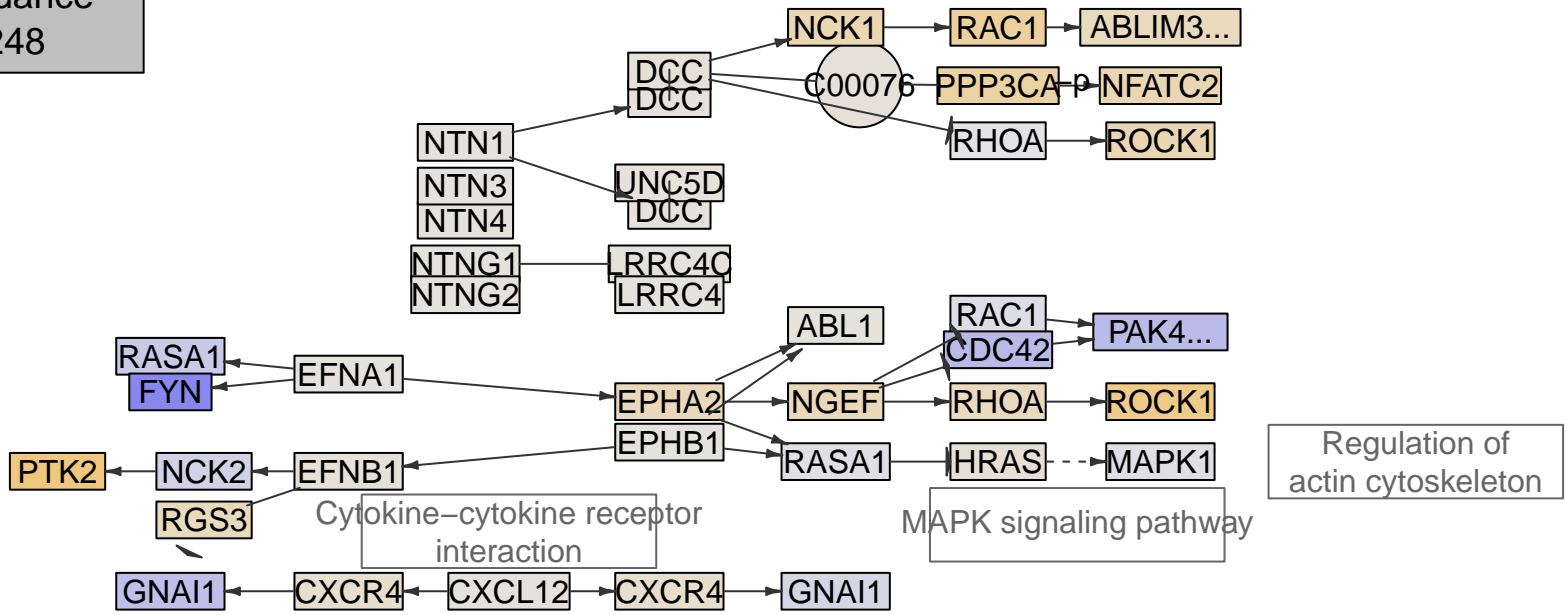

Axon guidance
MPI-249

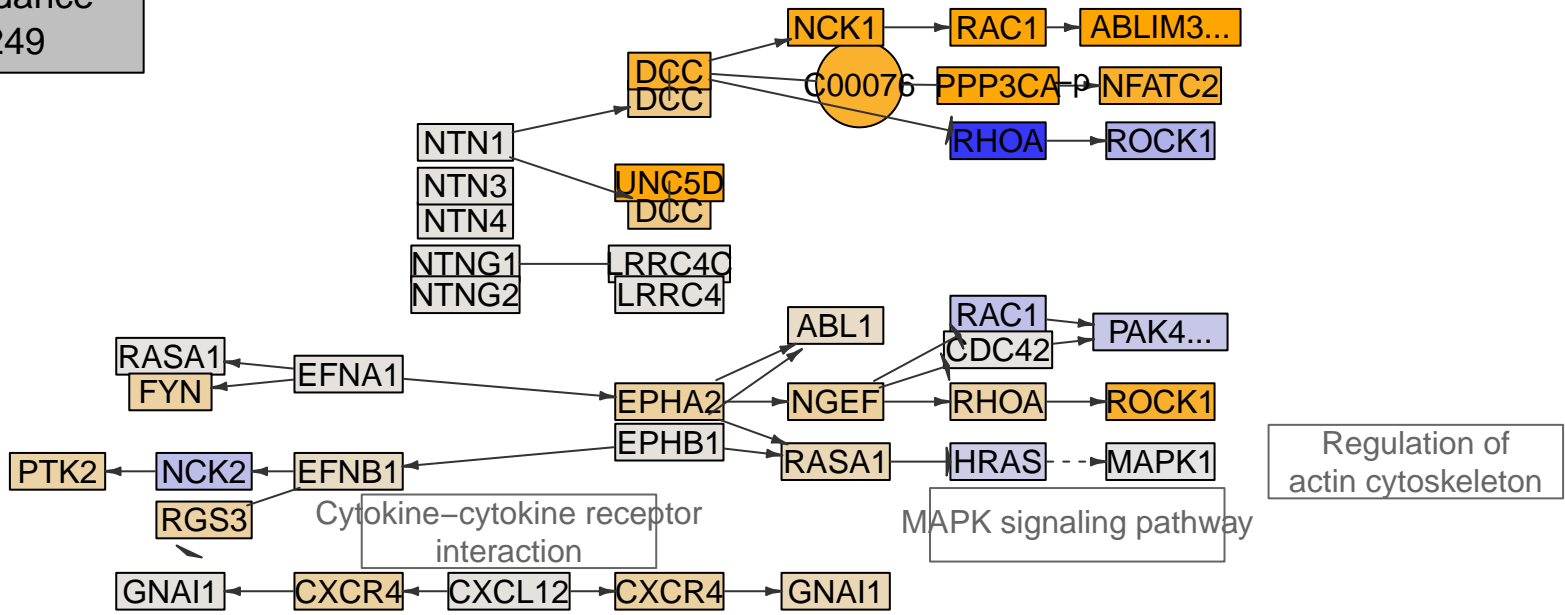

Regulation of actin cytoskeleton

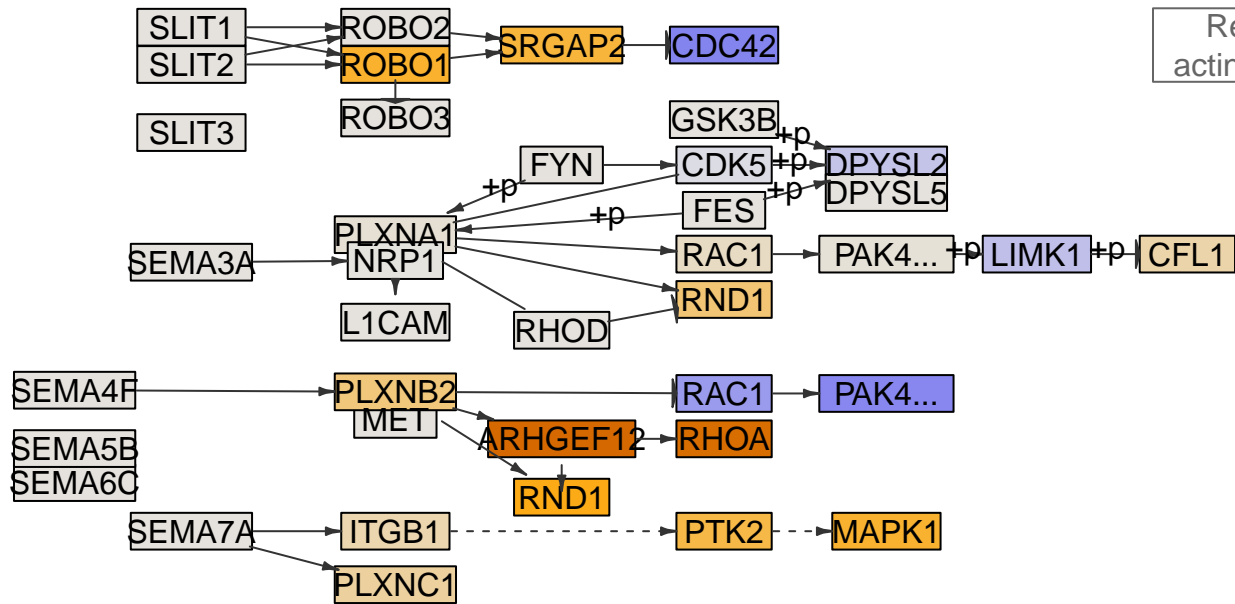

Regulation of actin cytoskeleton

Regulation of actin cytoskeleton

Axon guidance
MPI-250

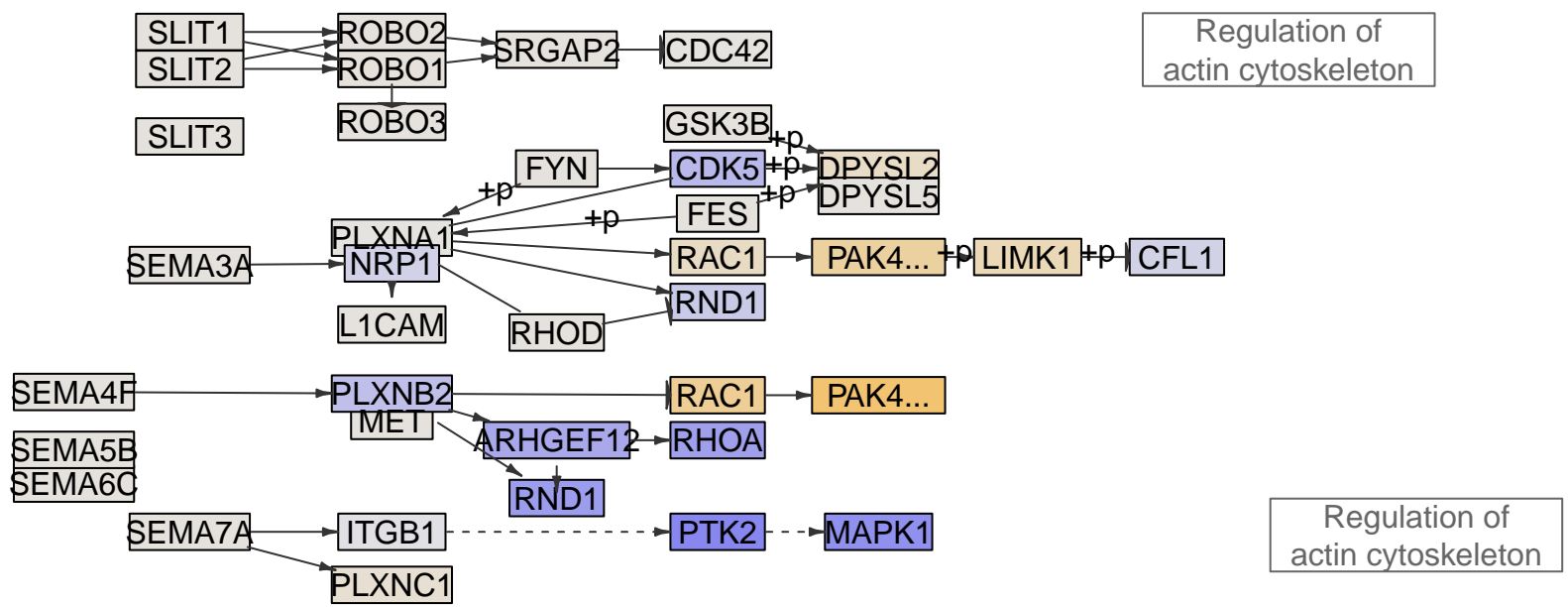
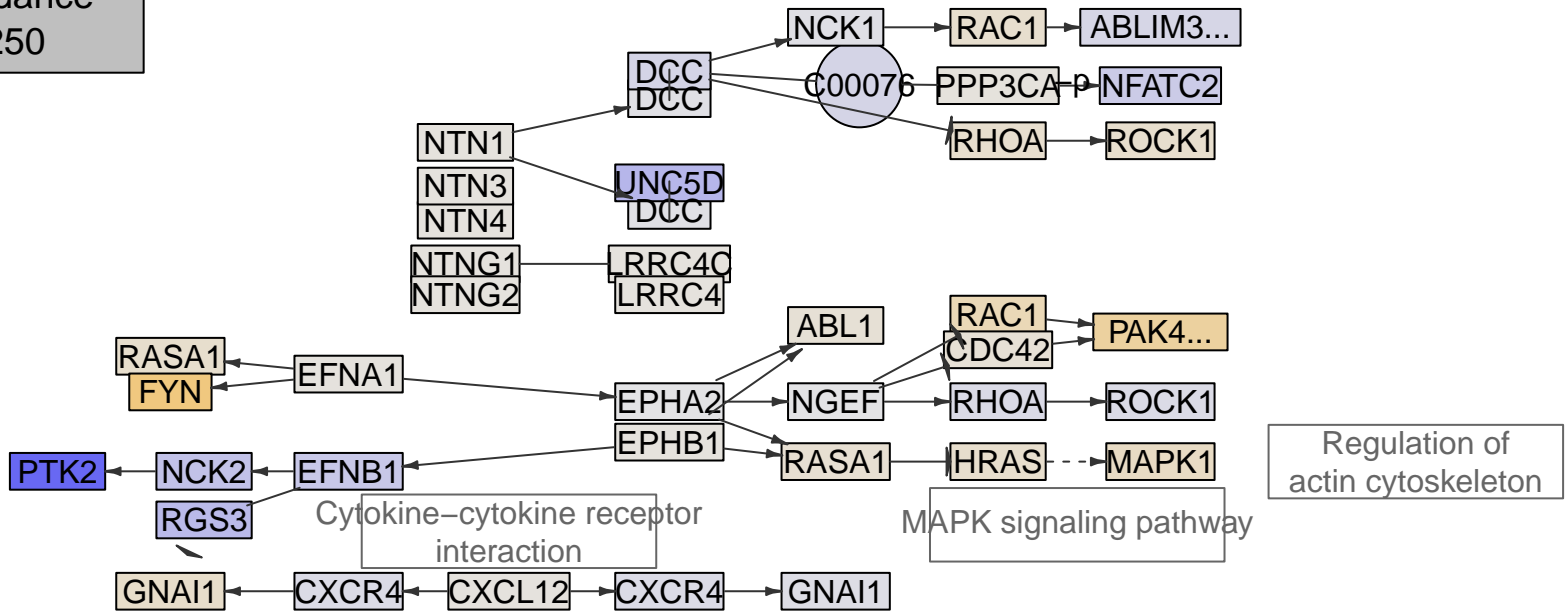

Axon guidance
MPI-008

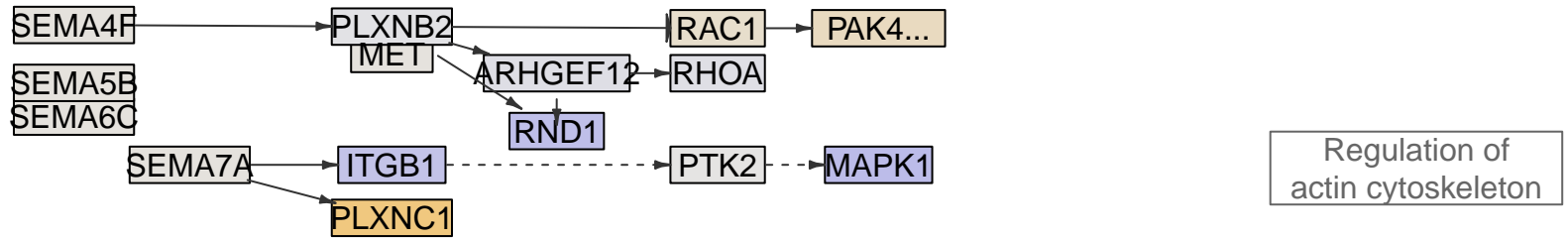
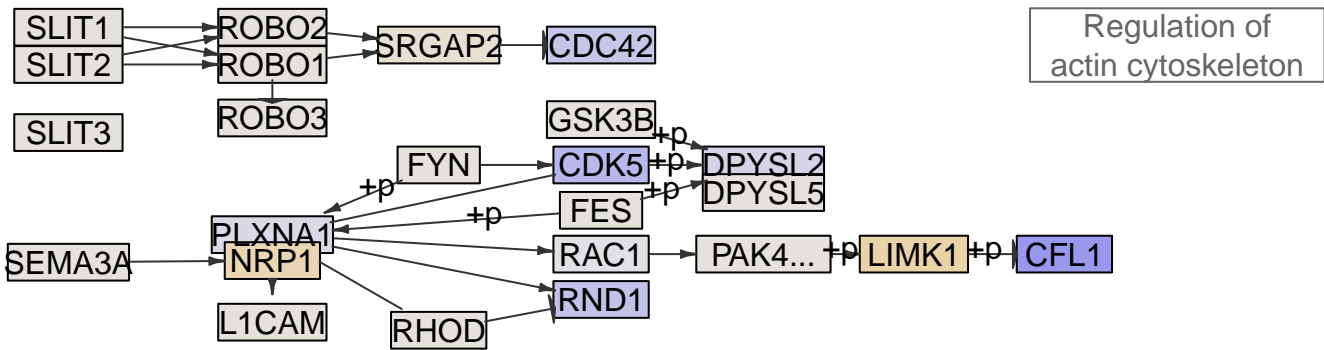
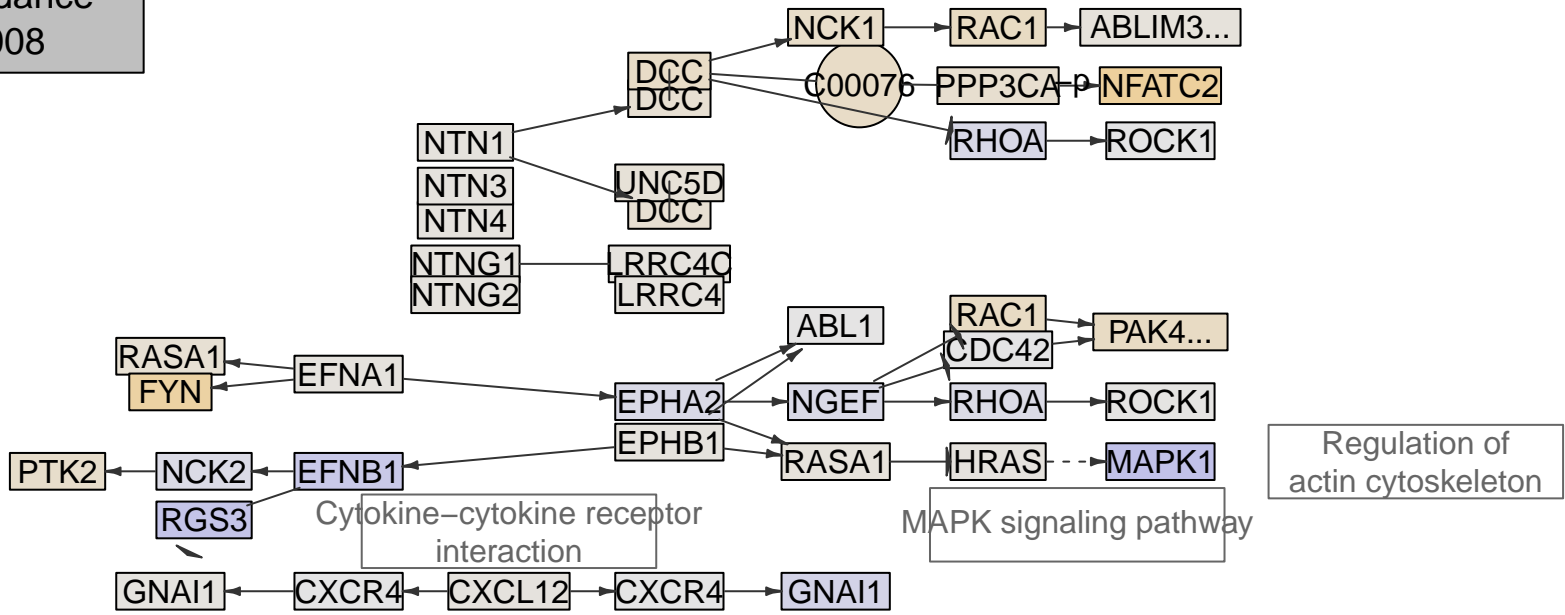

Axon guidance
MPI-009

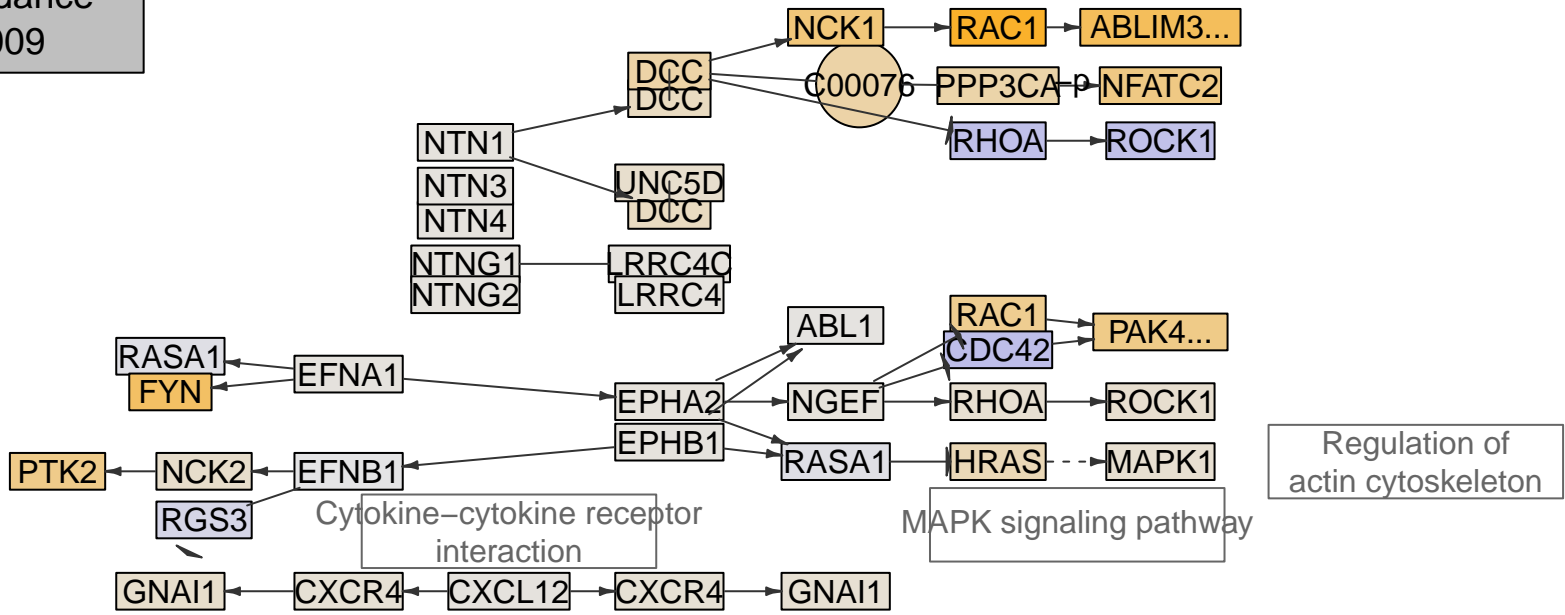

Regulation of actin cytoskeleton

MAPK signaling pathway

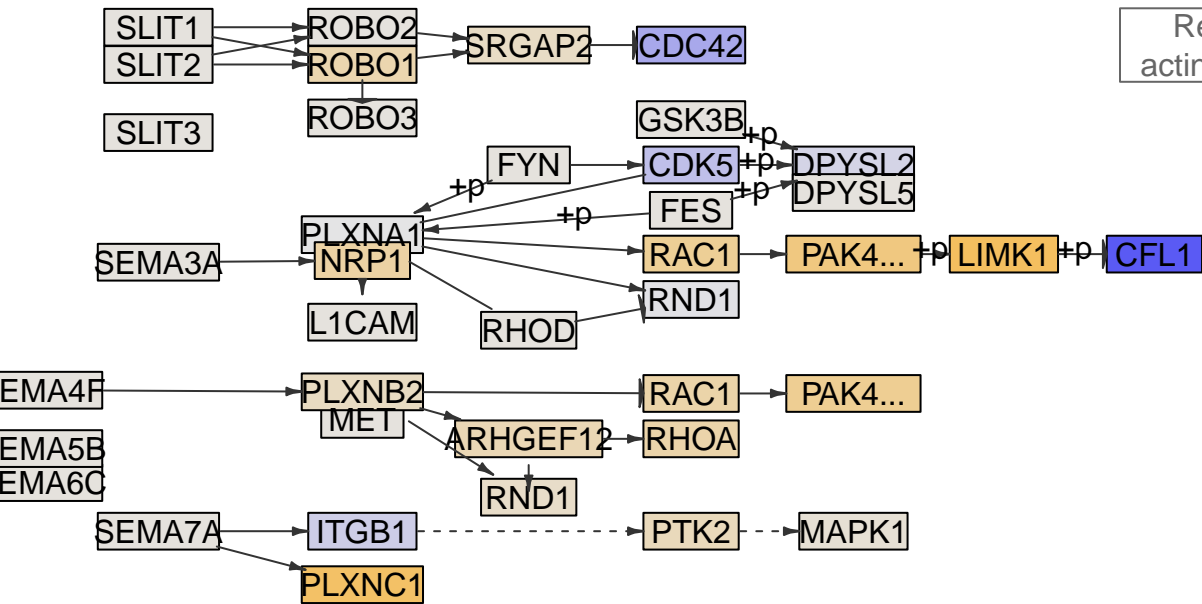

Regulation of actin cytoskeleton

Regulation of actin cytoskeleton

Axon guidance
MPI-010

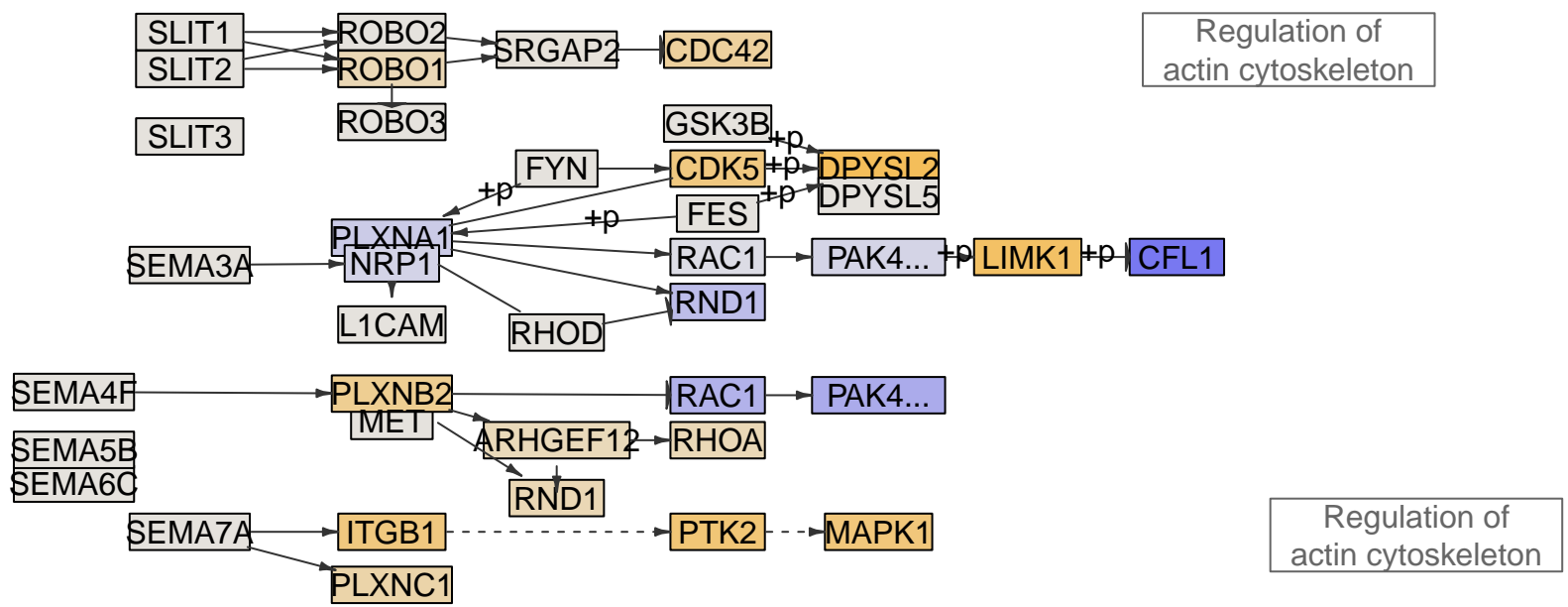
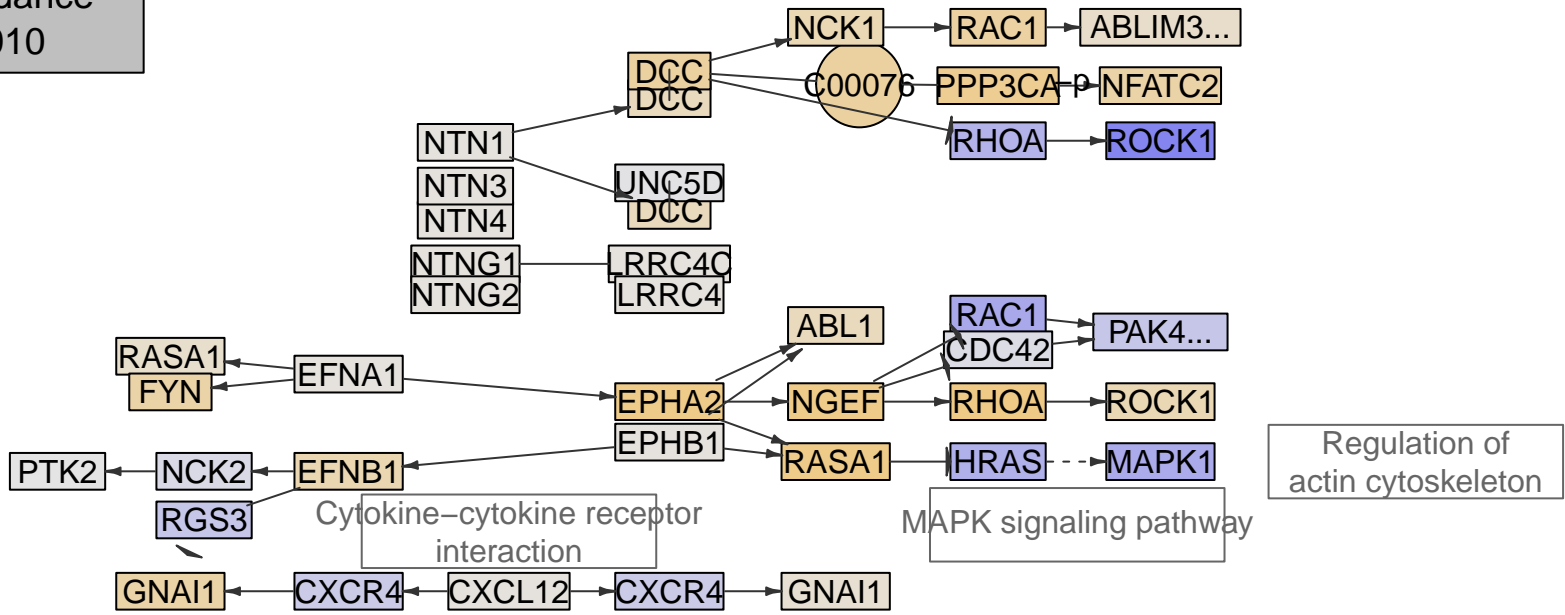

Axon guidance
MPI-012

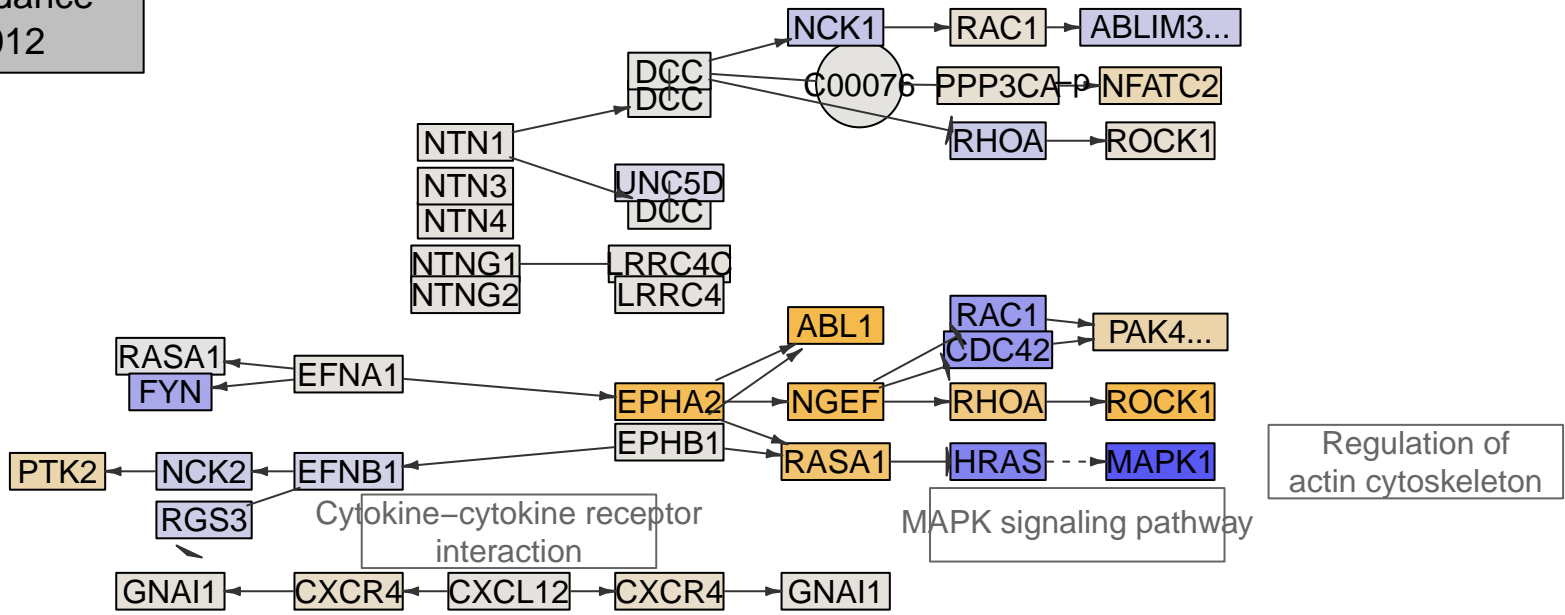

Regulation of actin cytoskeleton

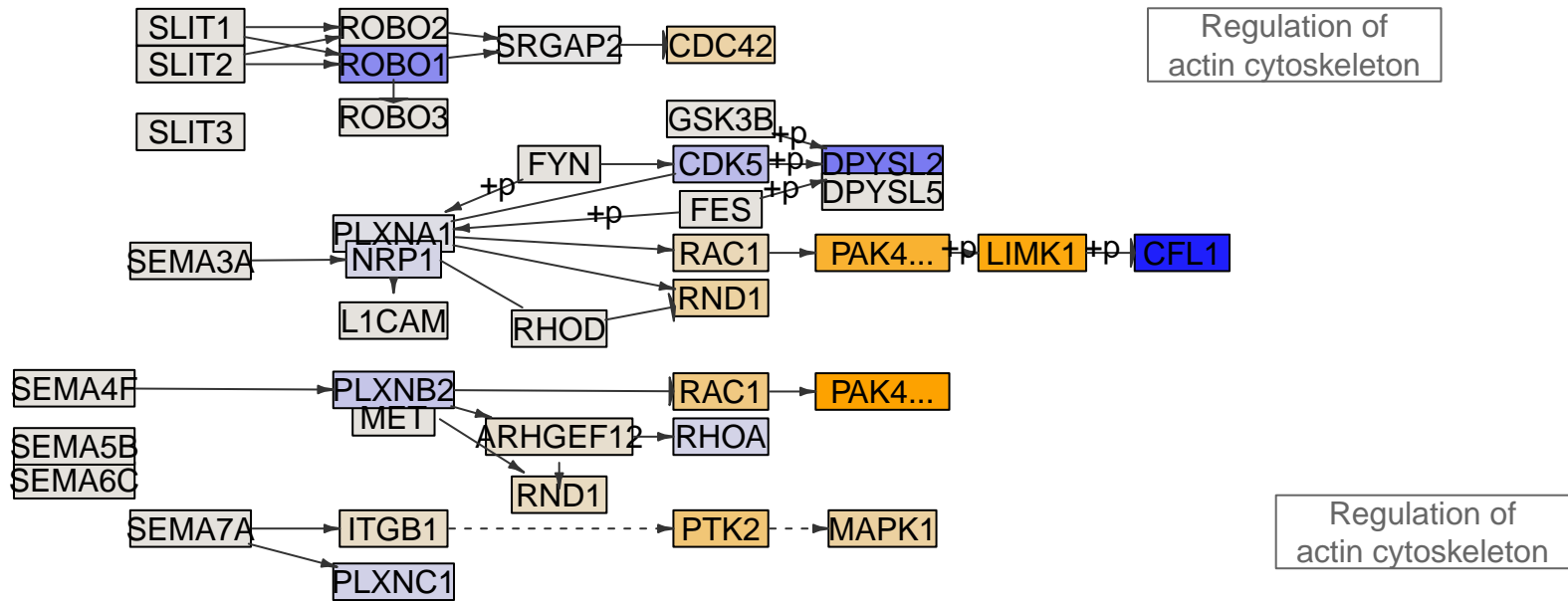

Regulation of actin cytoskeleton

Regulation of actin cytoskeleton

Axon guidance
MPI-013

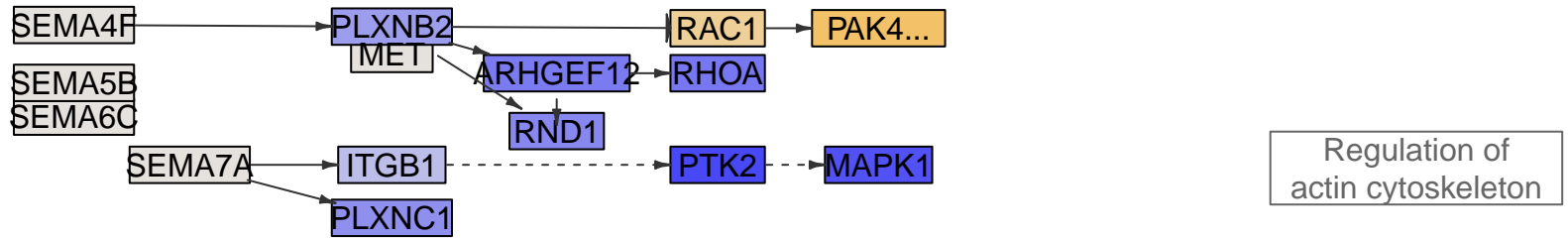
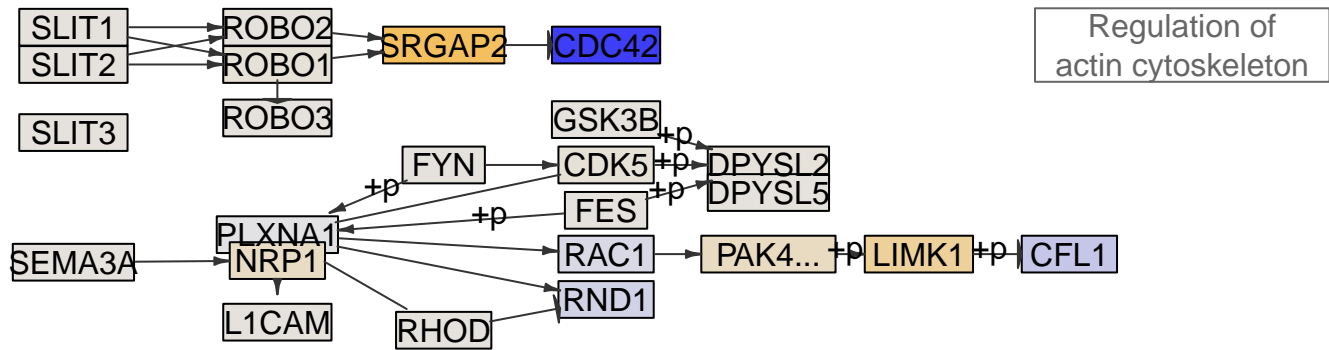
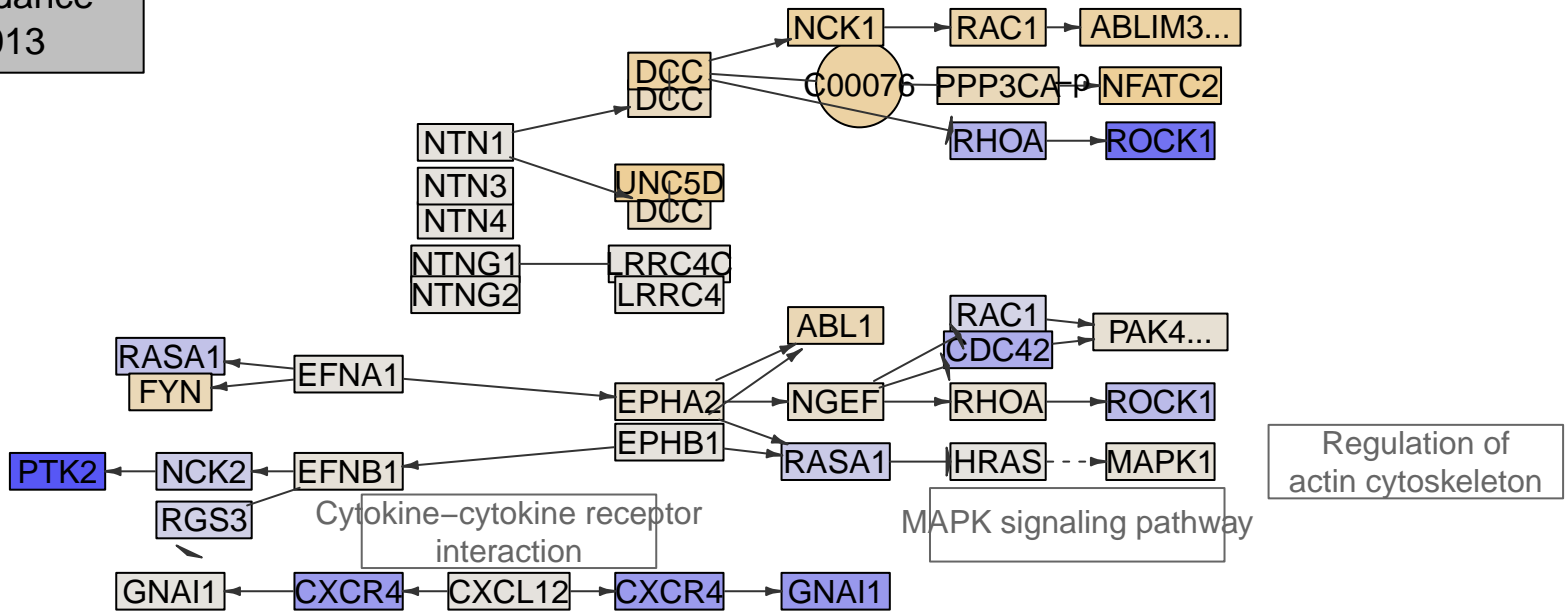

Axon guidance
MPI-014

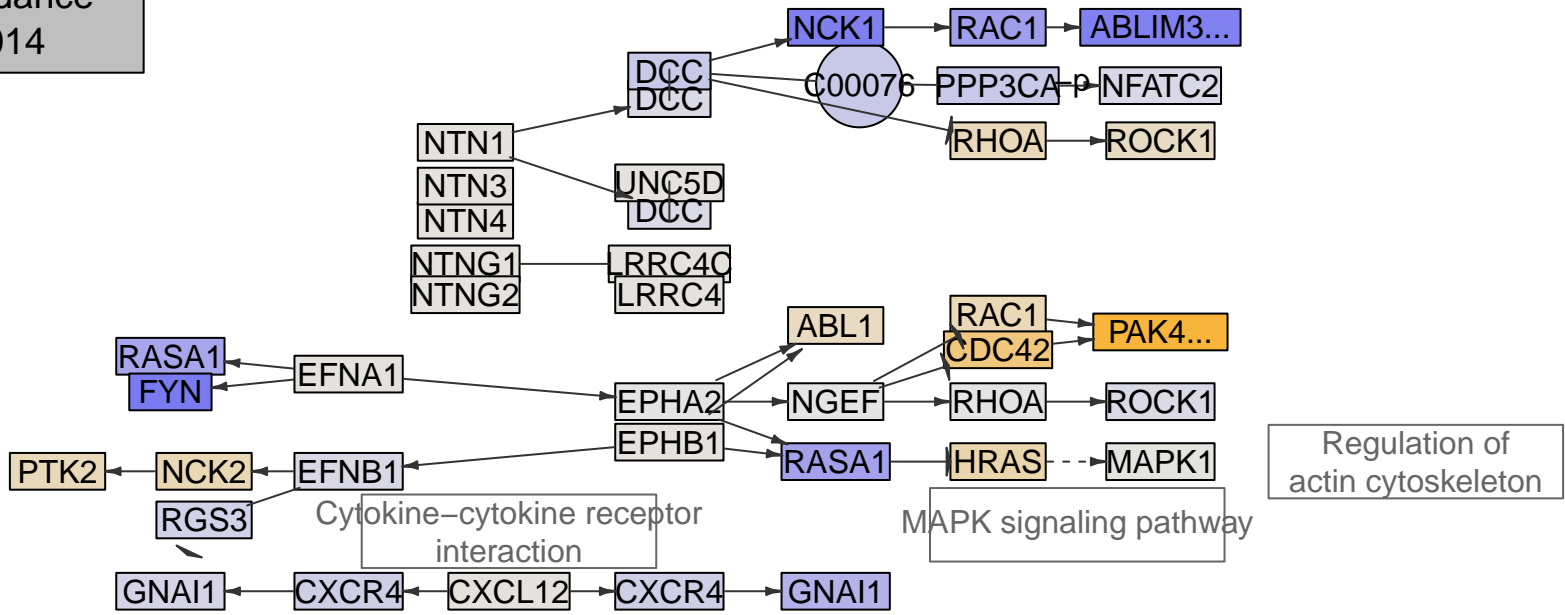

Regulation of actin cytoskeleton

MAPK signaling pathway

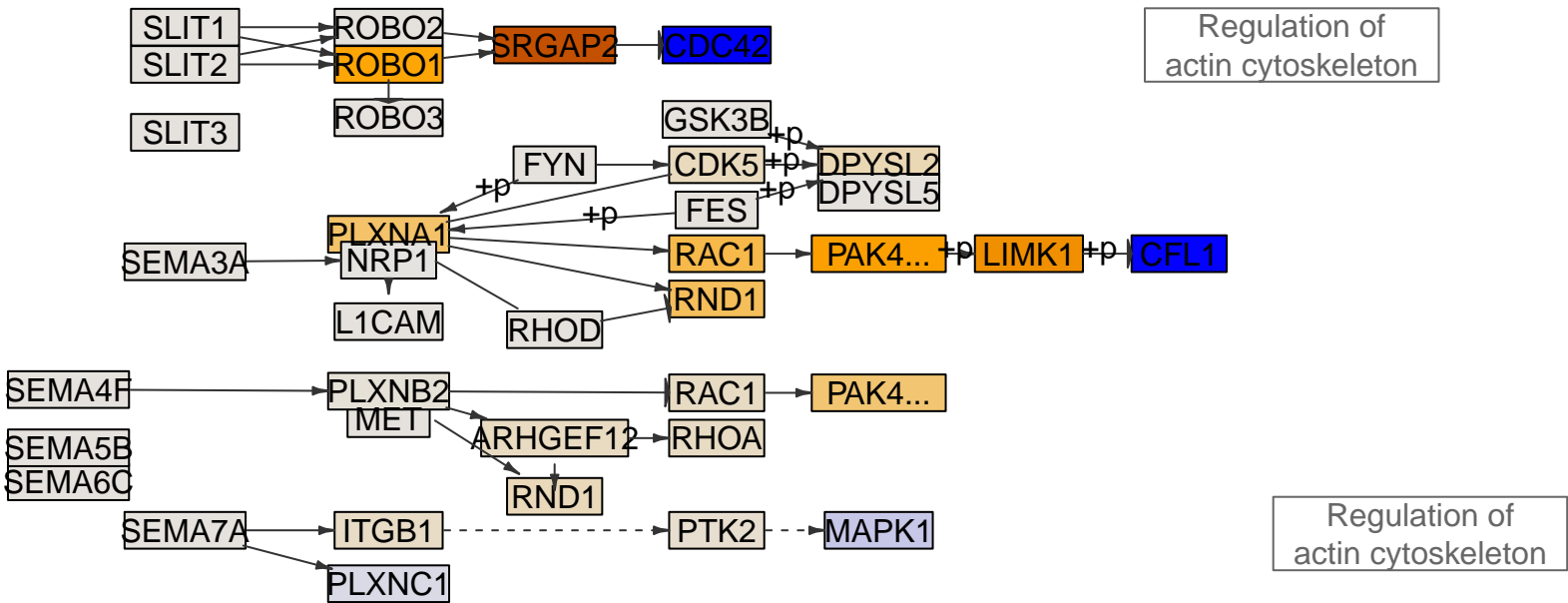

Regulation of actin cytoskeleton

Regulation of actin cytoskeleton

Axon guidance
MPI-015

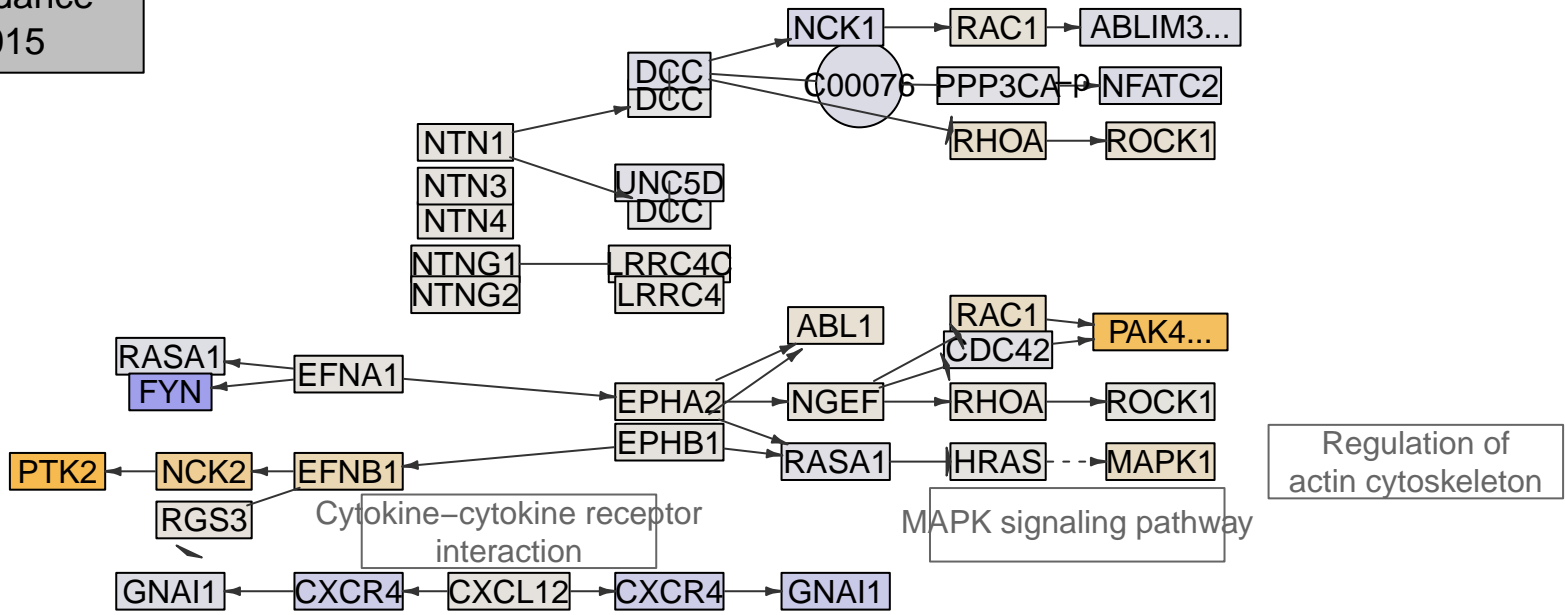

Regulation of actin cytoskeleton

MAPK signaling pathway

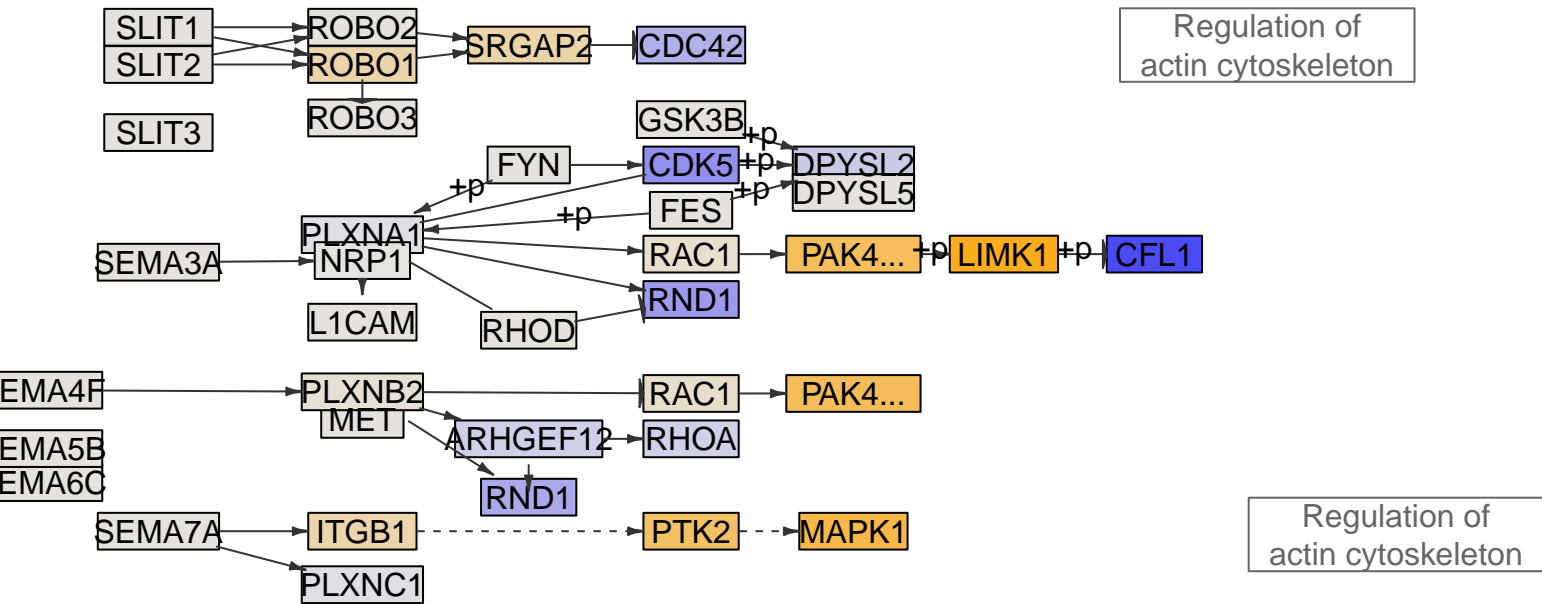

Regulation of actin cytoskeleton

Regulation of actin cytoskeleton

Axon guidance
MPI-021

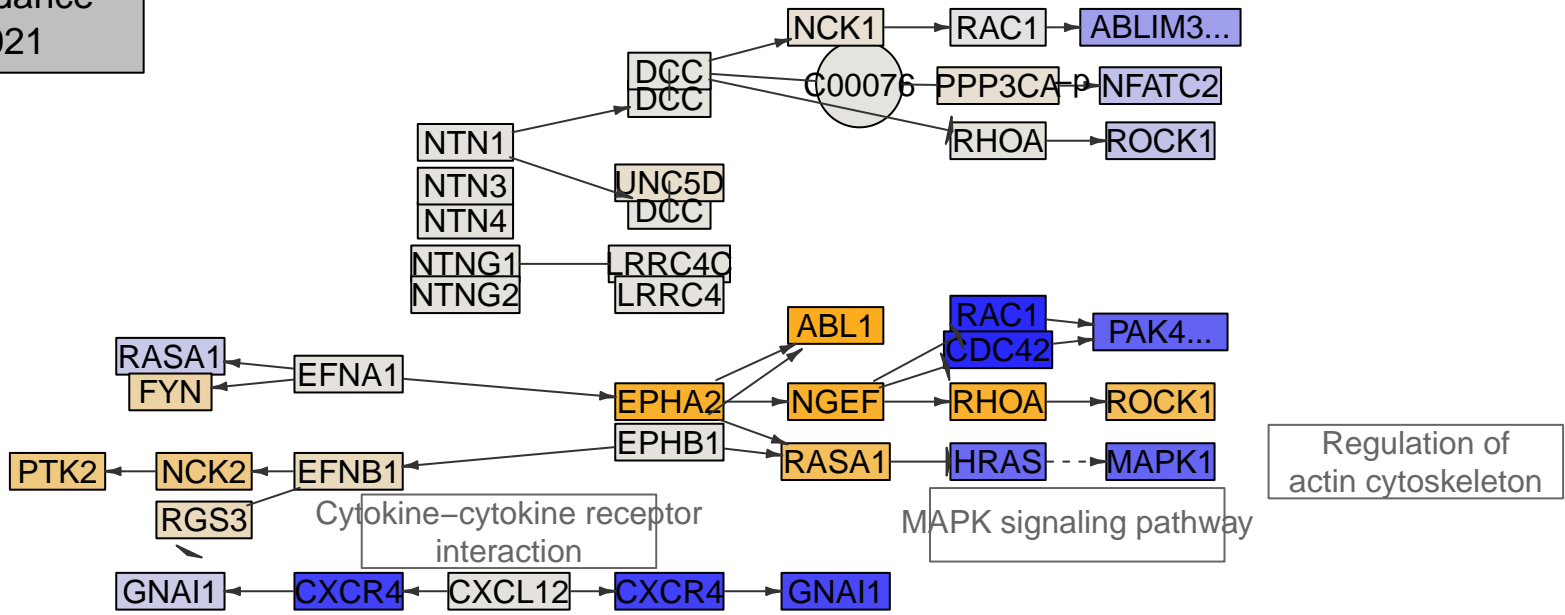

Regulation of actin cytoskeleton

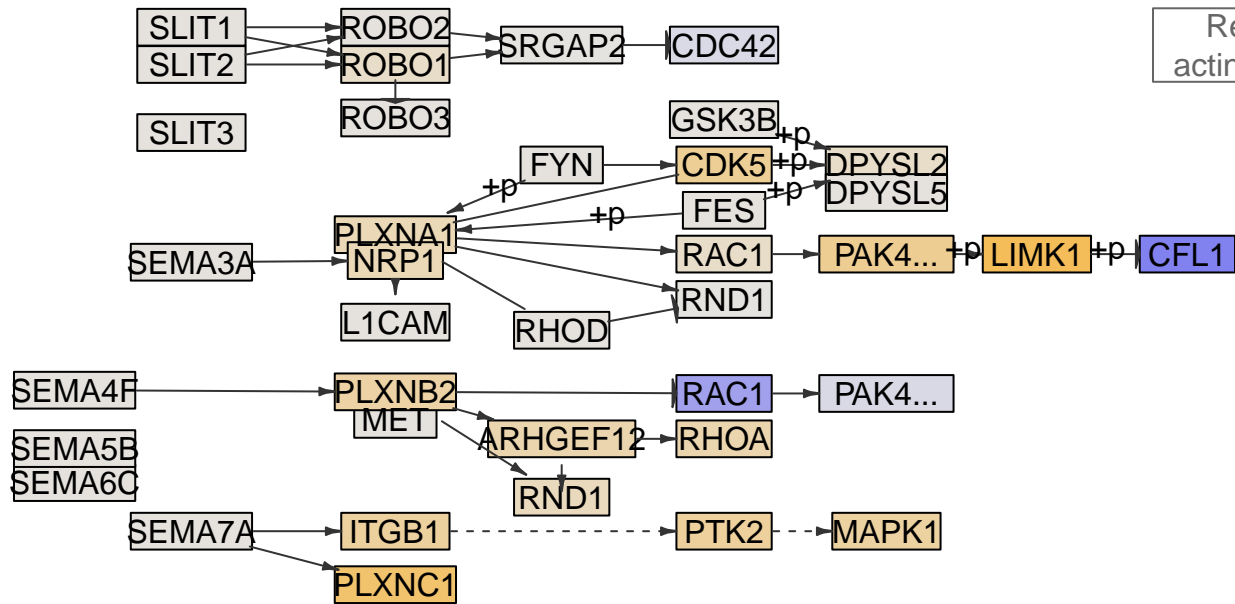

Regulation of actin cytoskeleton

Regulation of actin cytoskeleton

Axon guidance
MPI-022

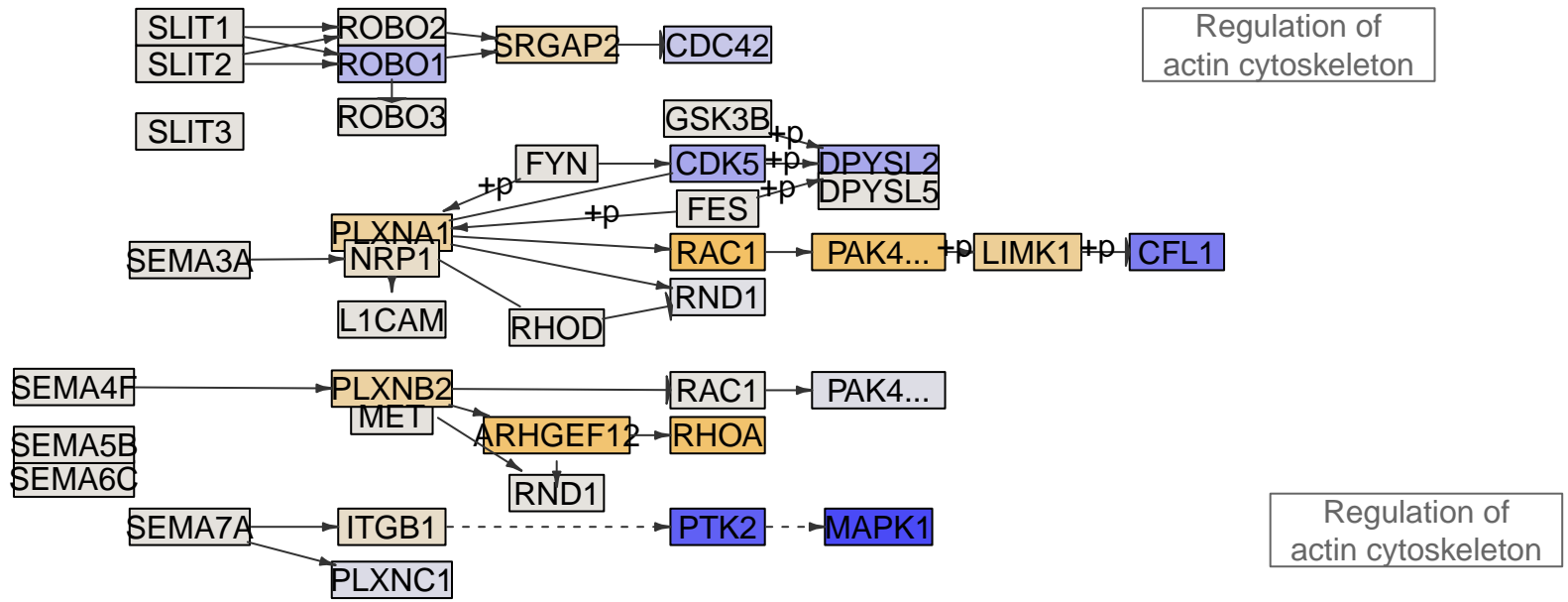
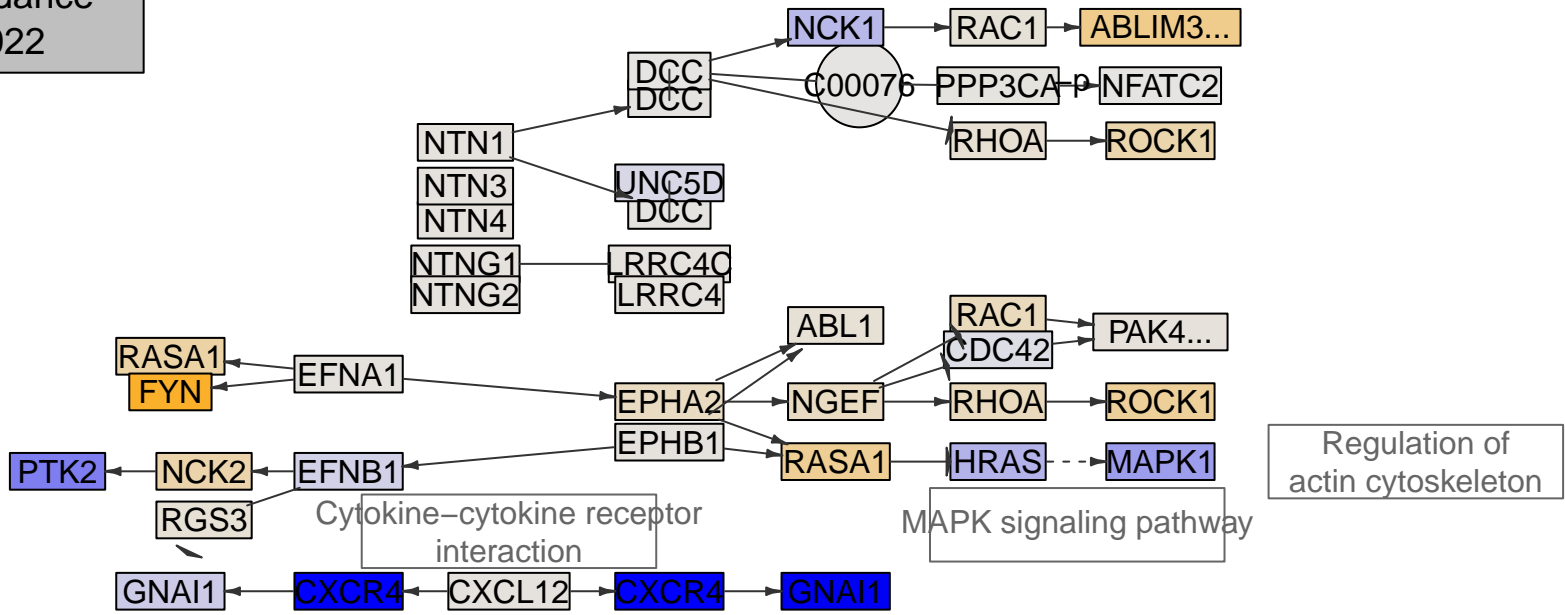

Regulation of actin cytoskeleton

Axon guidance
MPI-025

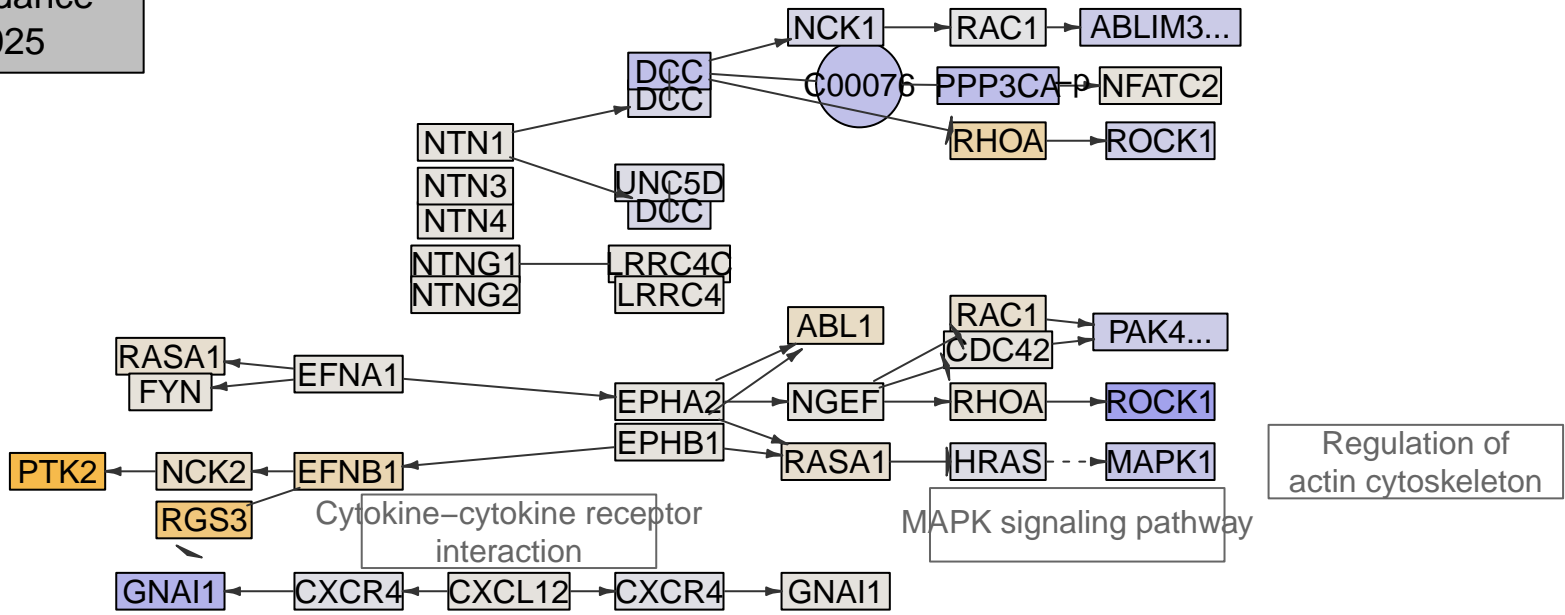

Regulation of actin cytoskeleton

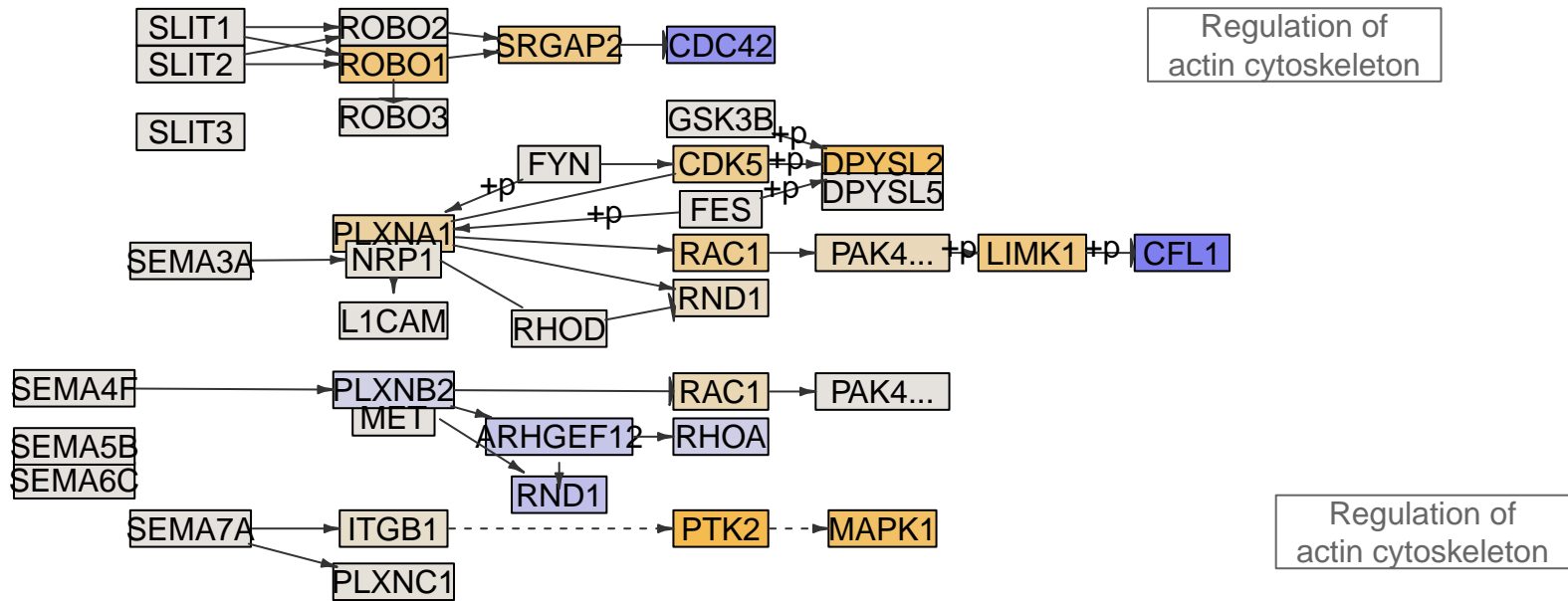

Regulation of actin cytoskeleton

Regulation of actin cytoskeleton

Axon guidance
MPI-029

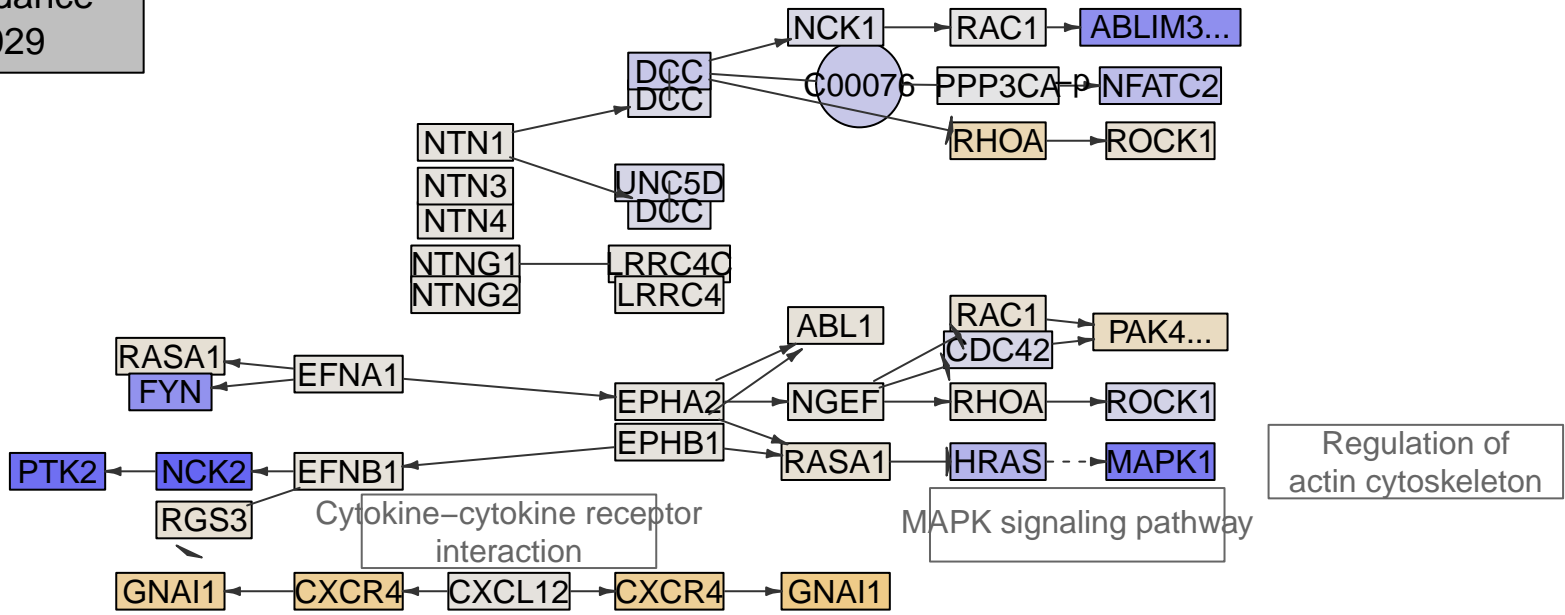

Regulation of actin cytoskeleton

MAPK signaling pathway

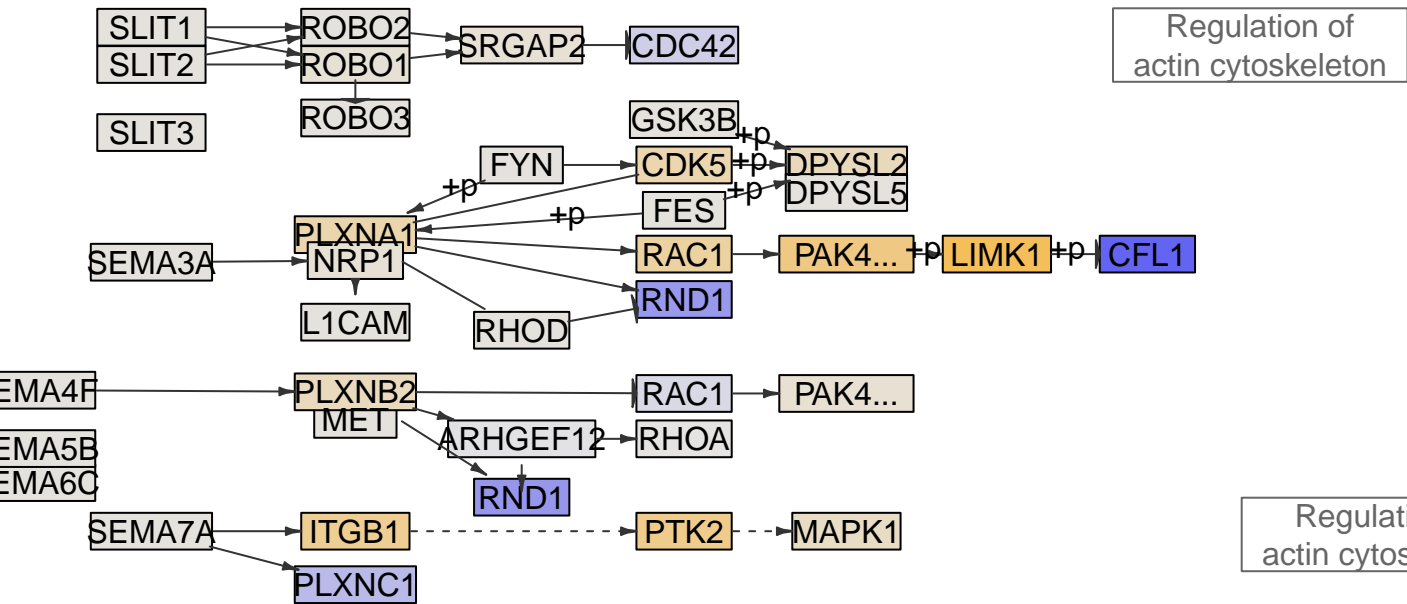

Regulation of actin cytoskeleton

Regulation of actin cytoskeleton

Axon guidance
MPI-030

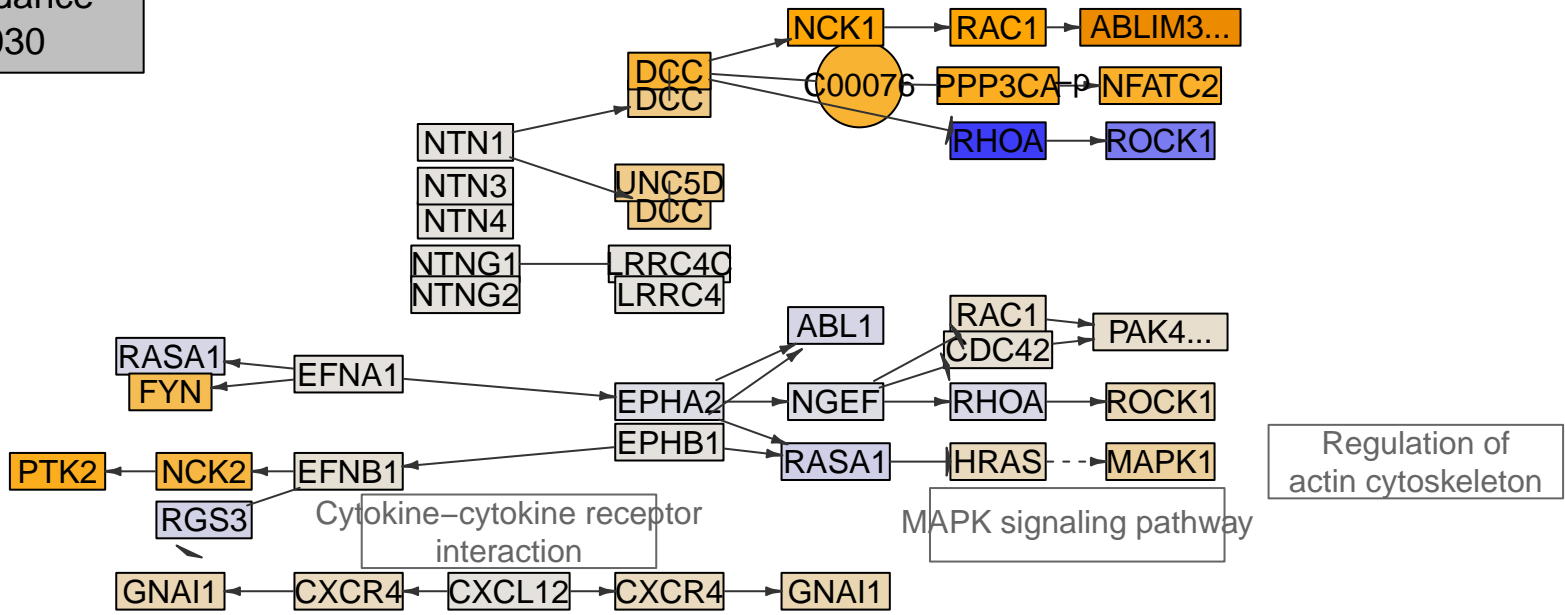

Regulation of actin cytoskeleton

MAPK signaling pathway

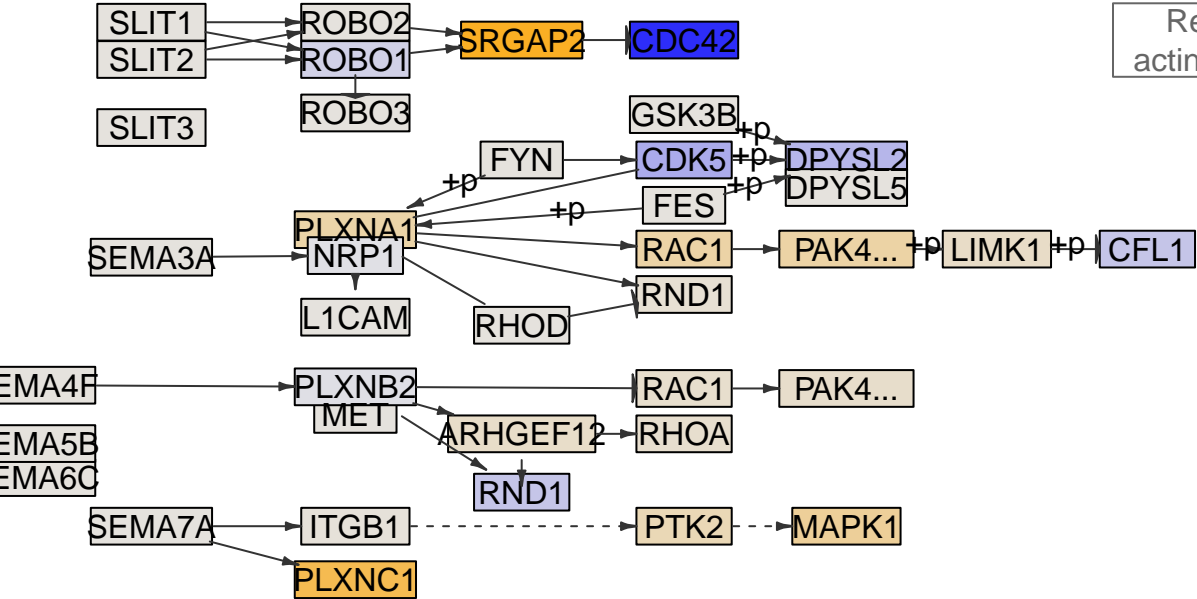

Regulation of actin cytoskeleton

Regulation of actin cytoskeleton

Axon guidance
MPI-031

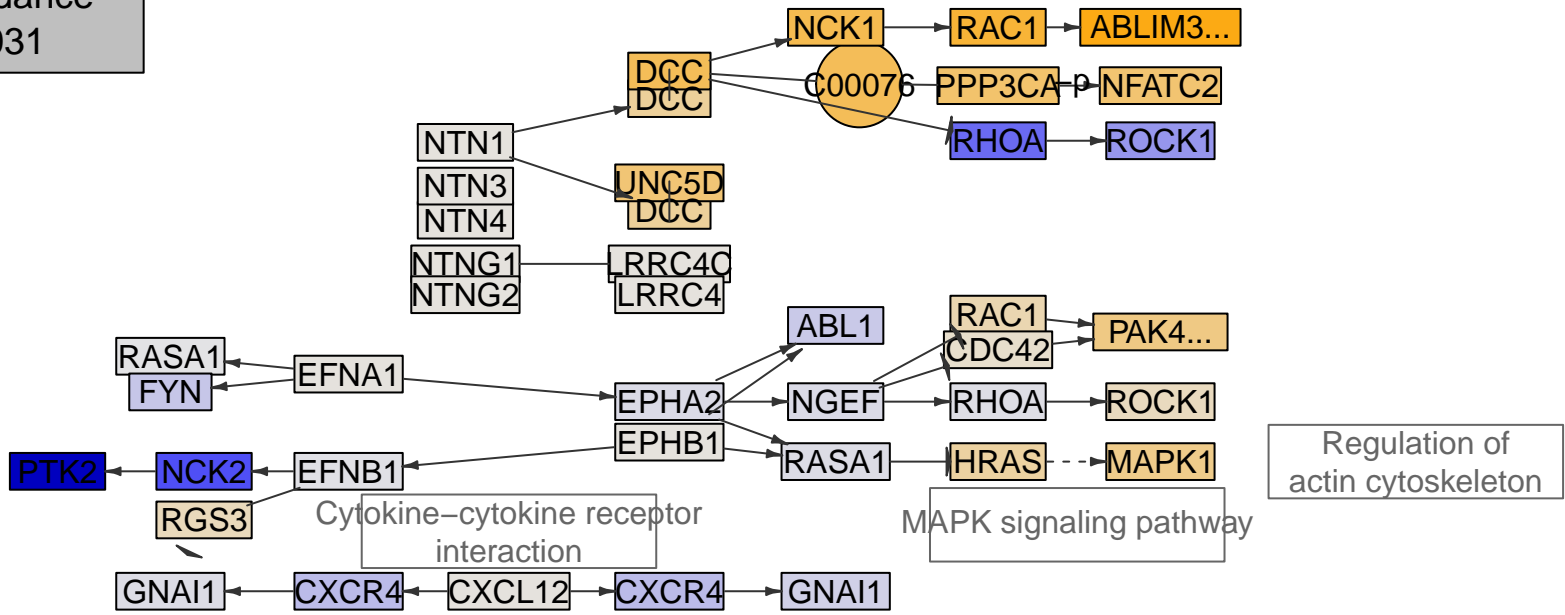

Regulation of actin cytoskeleton

MAPK signaling pathway

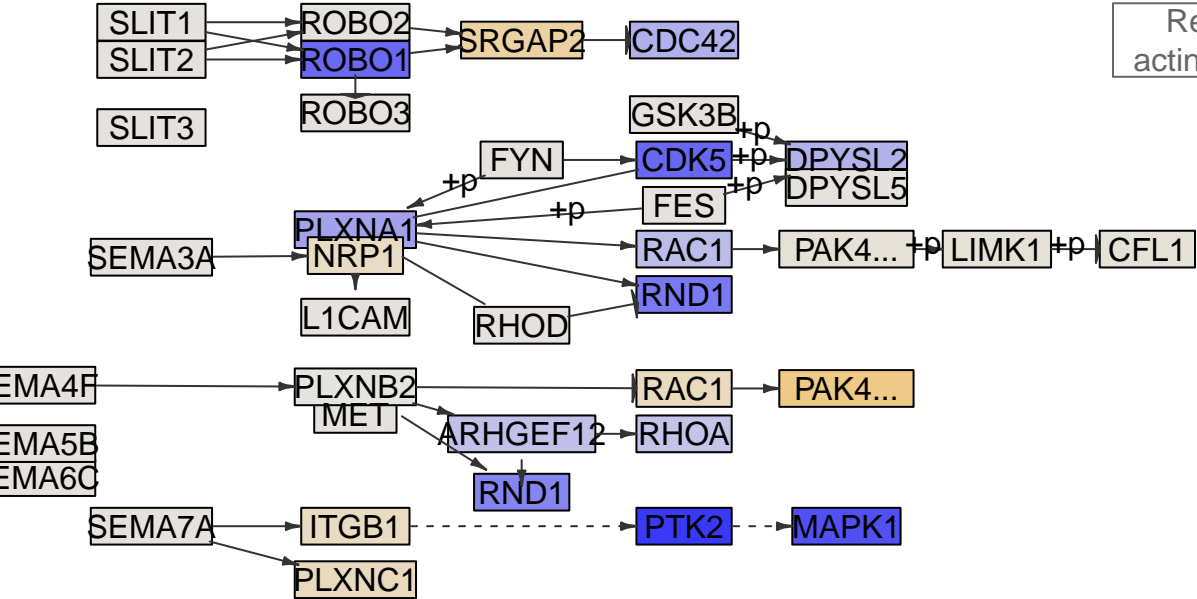

Regulation of actin cytoskeleton

Regulation of actin cytoskeleton

Axon guidance
MPI-039

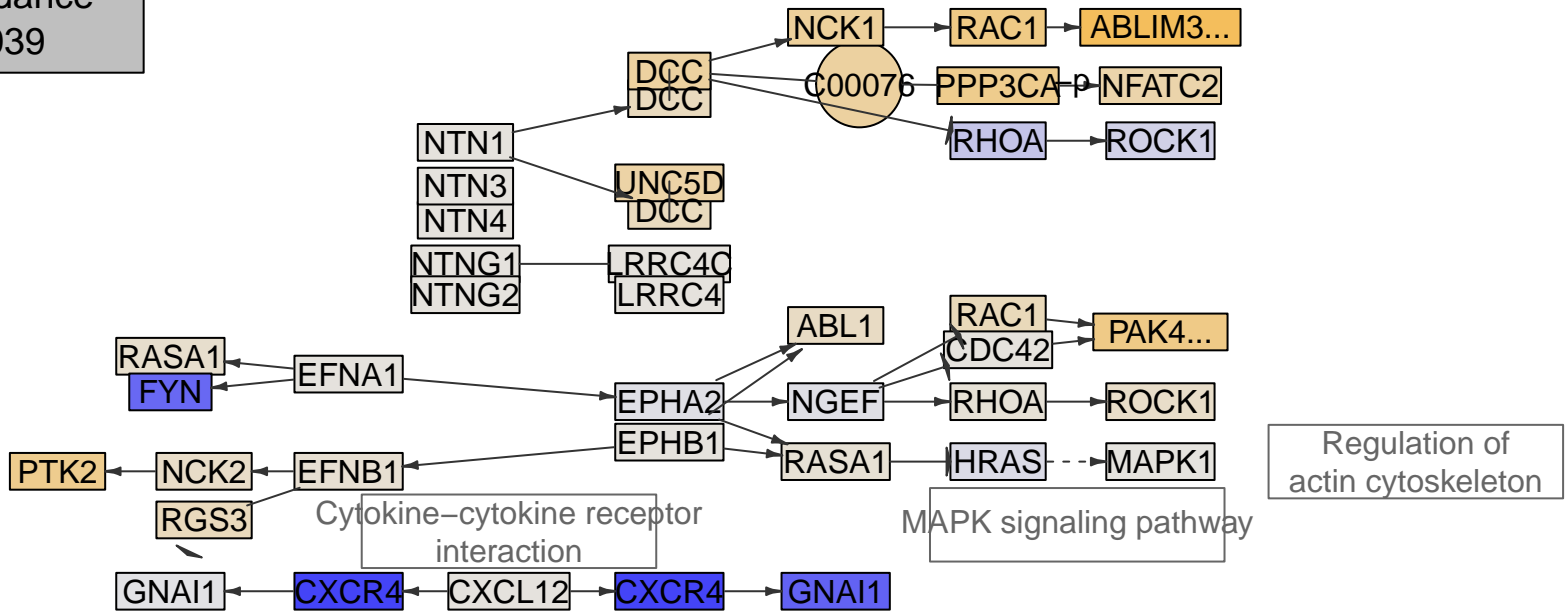

Regulation of actin cytoskeleton

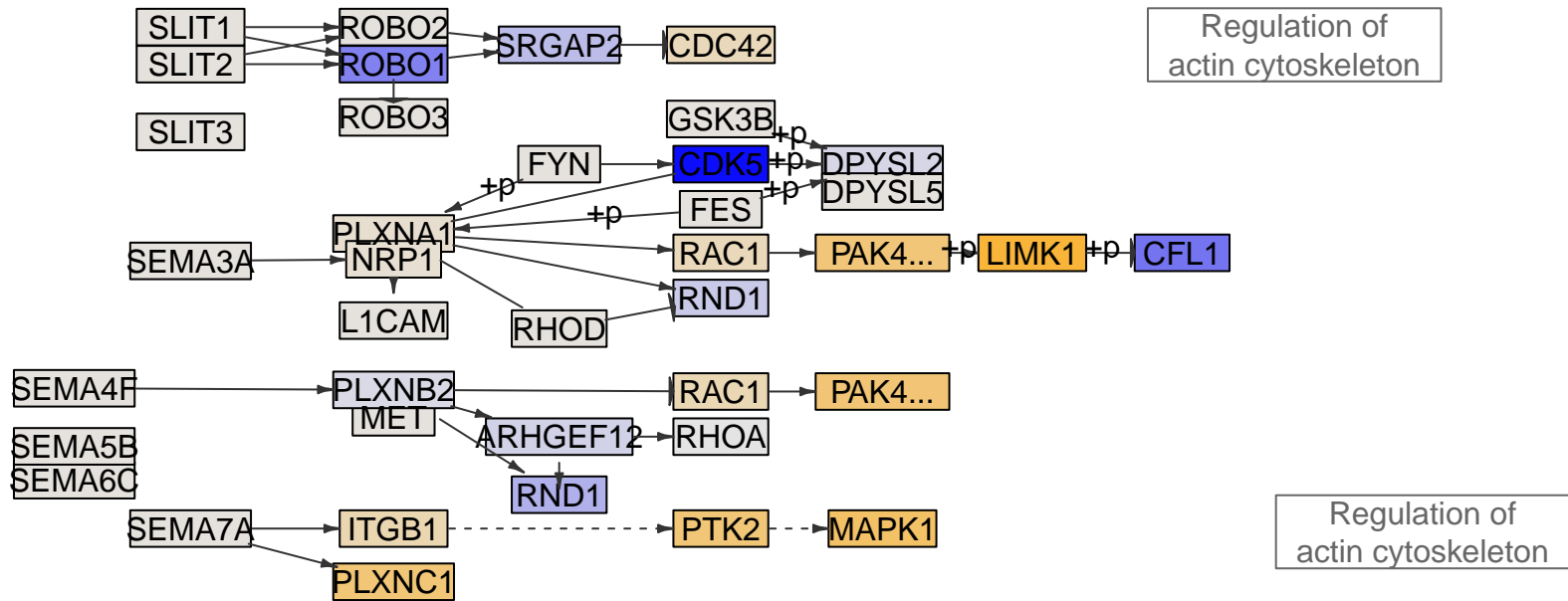

Regulation of actin cytoskeleton

Regulation of actin cytoskeleton

Axon guidance
MPI-040

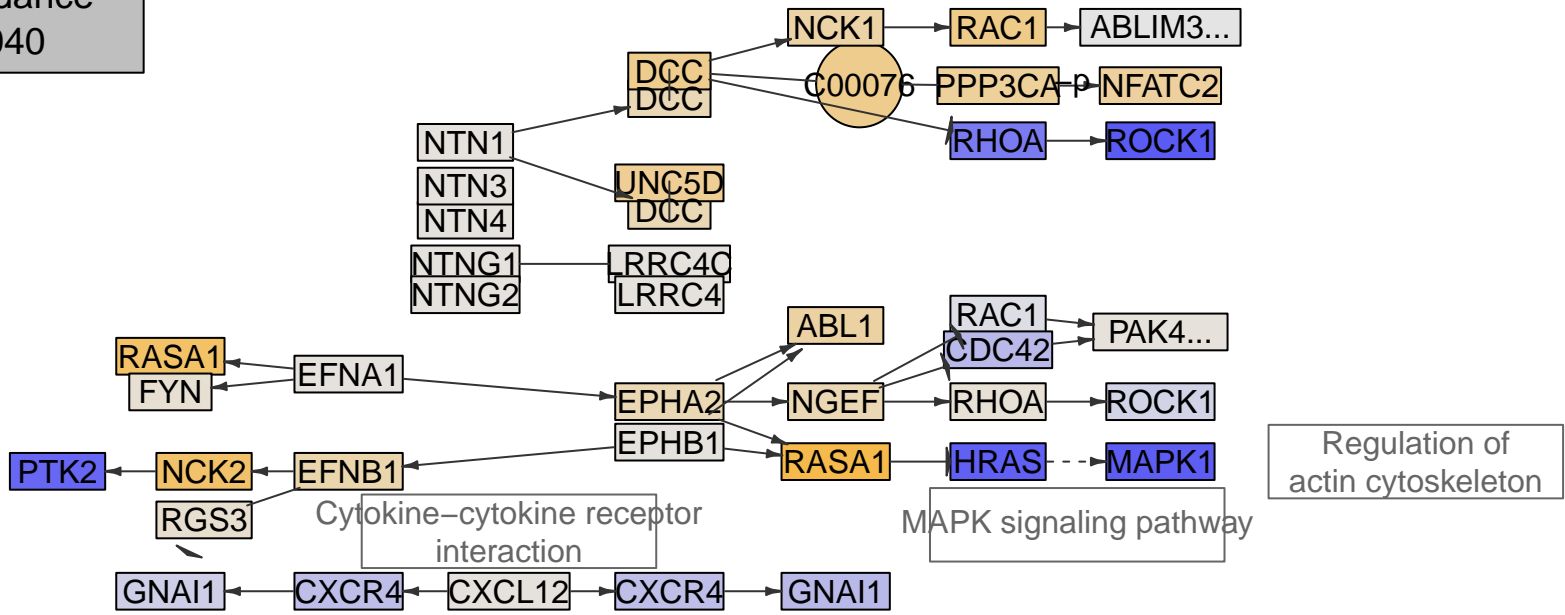

Regulation of actin cytoskeleton

MAPK signaling pathway

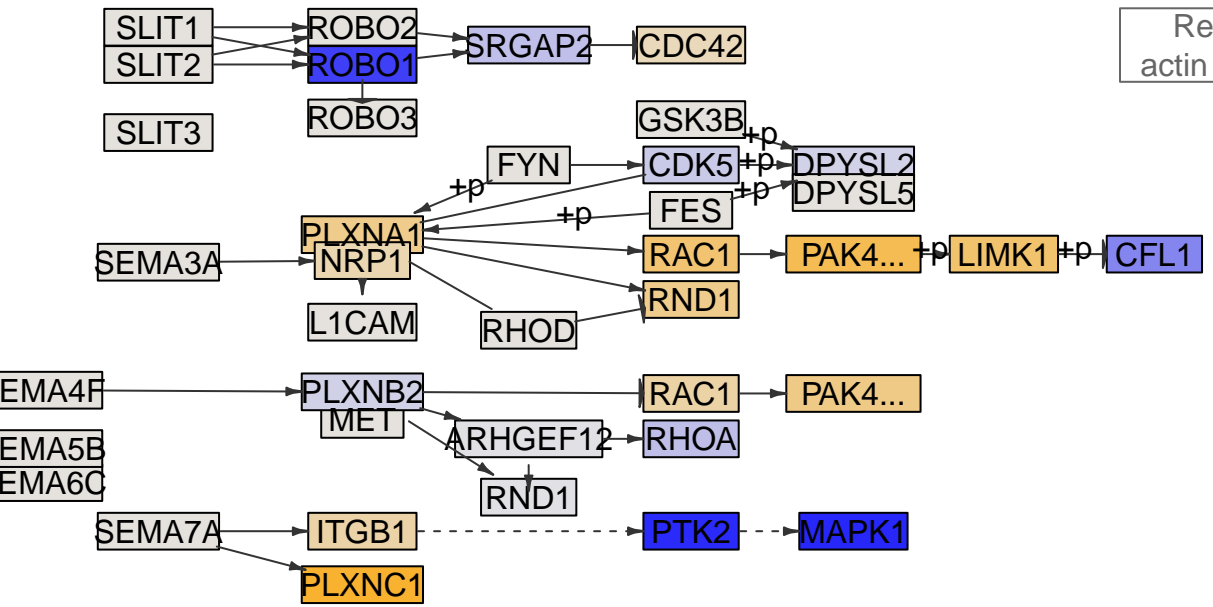

Regulation of actin cytoskeleton

Regulation of actin cytoskeleton

Axon guidance
MPI-045

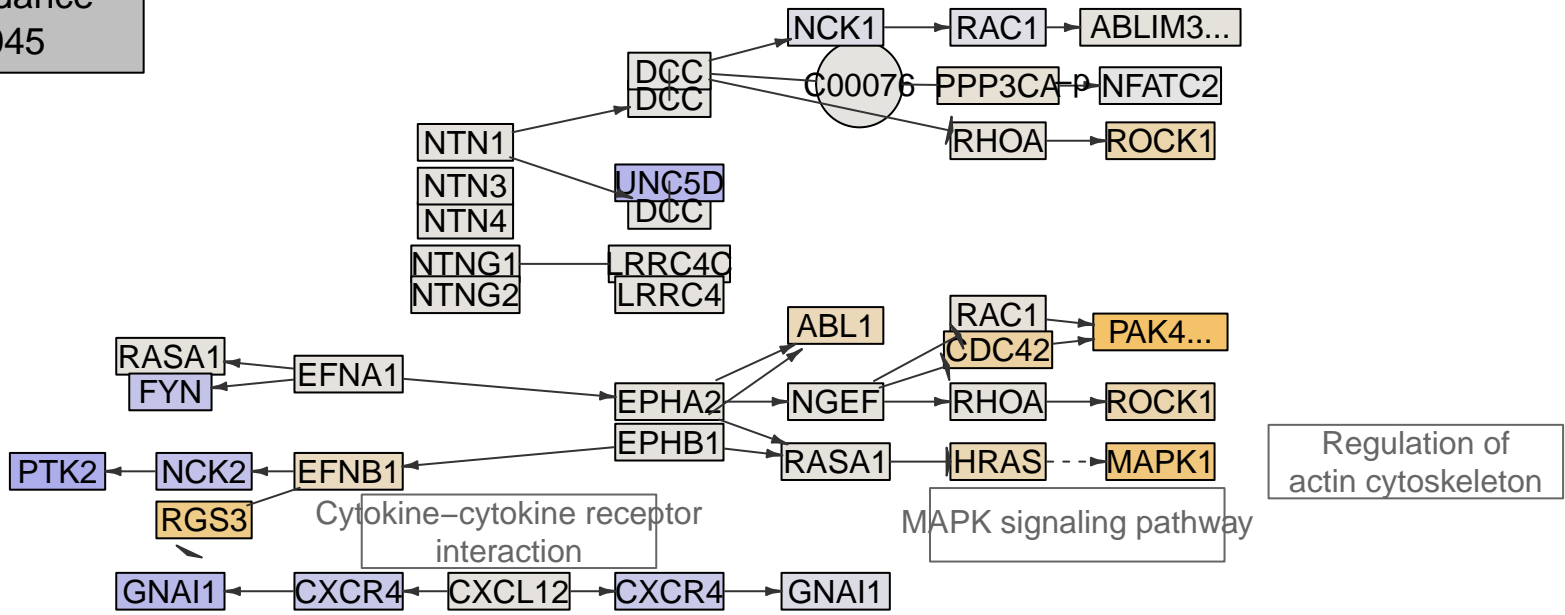

Regulation of actin cytoskeleton

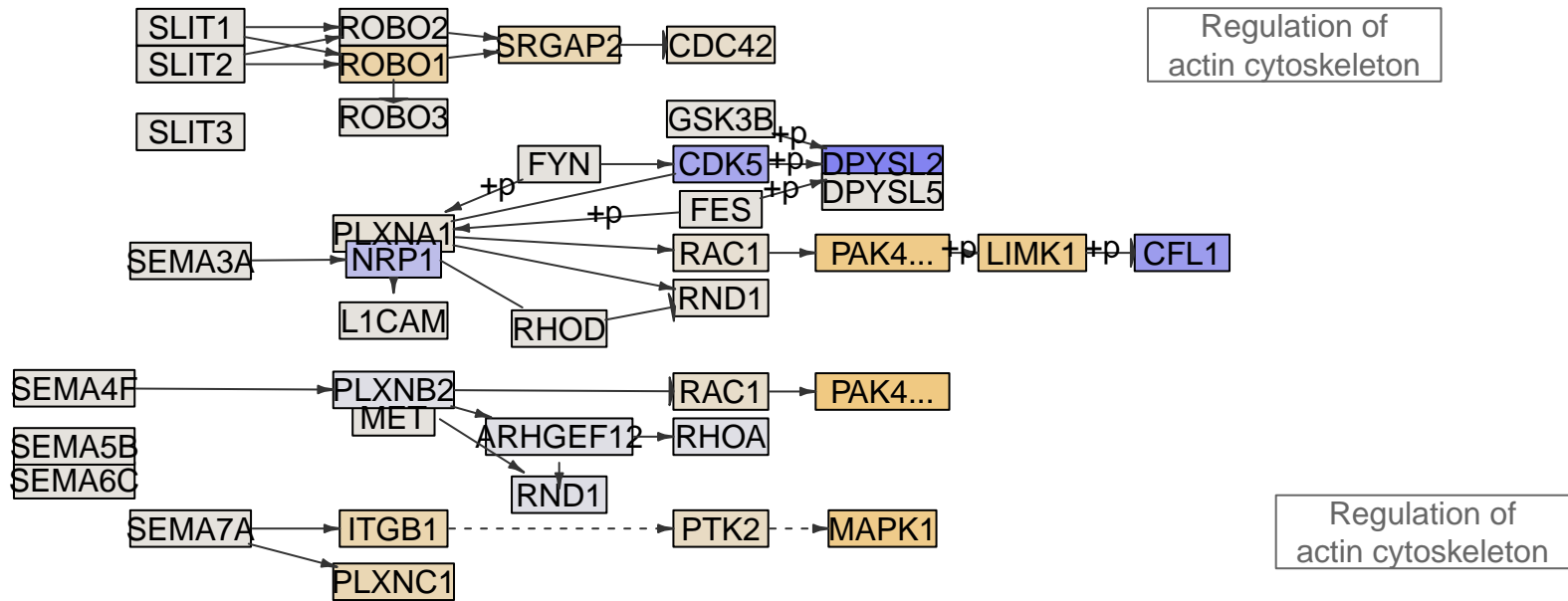

Regulation of actin cytoskeleton

Regulation of actin cytoskeleton

Axon guidance
MPI-047

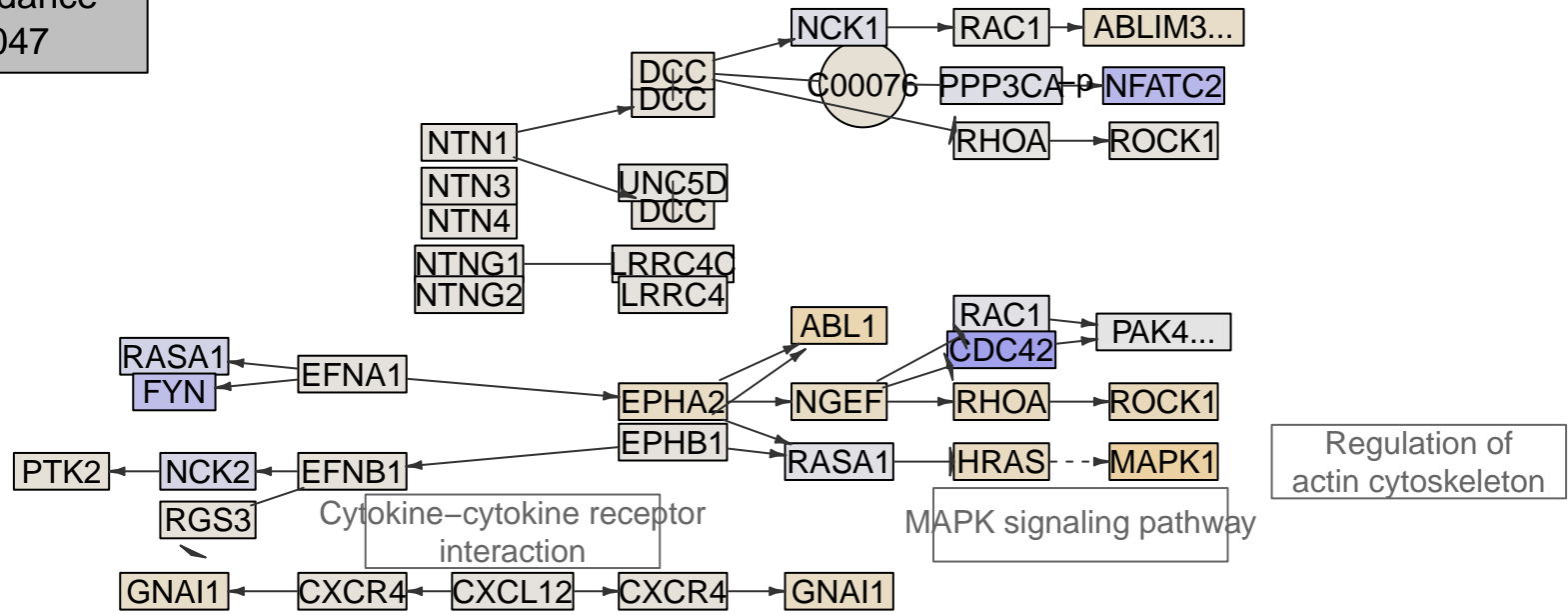

Regulation of actin cytoskeleton

MAPK signaling pathway

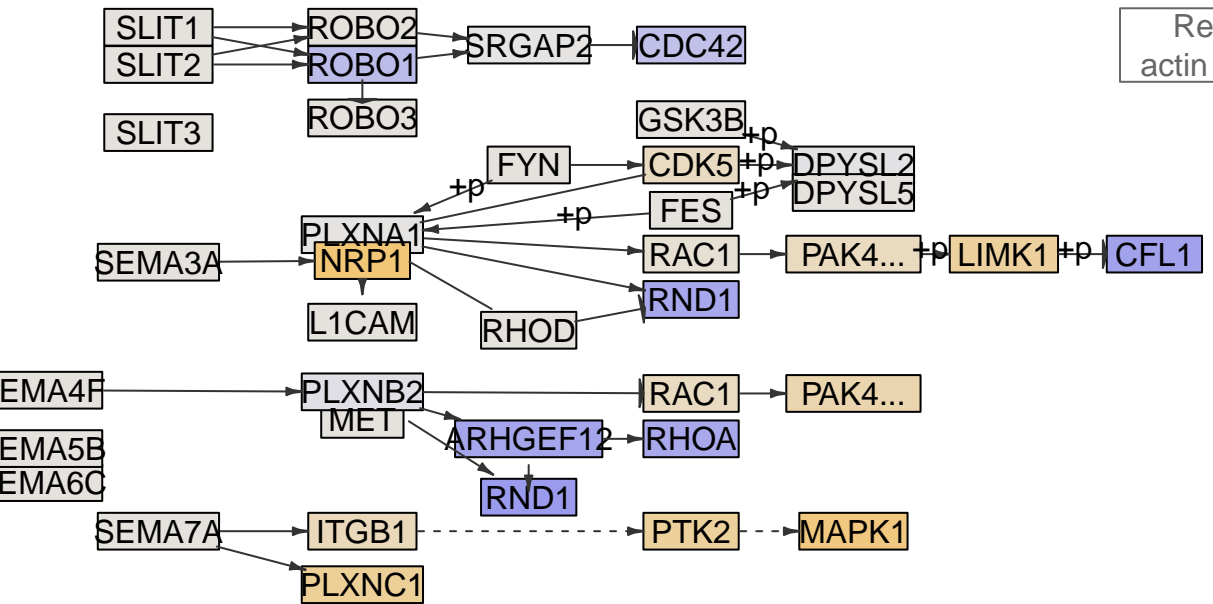

Regulation of actin cytoskeleton

Regulation of actin cytoskeleton

Axon guidance
MPI-053

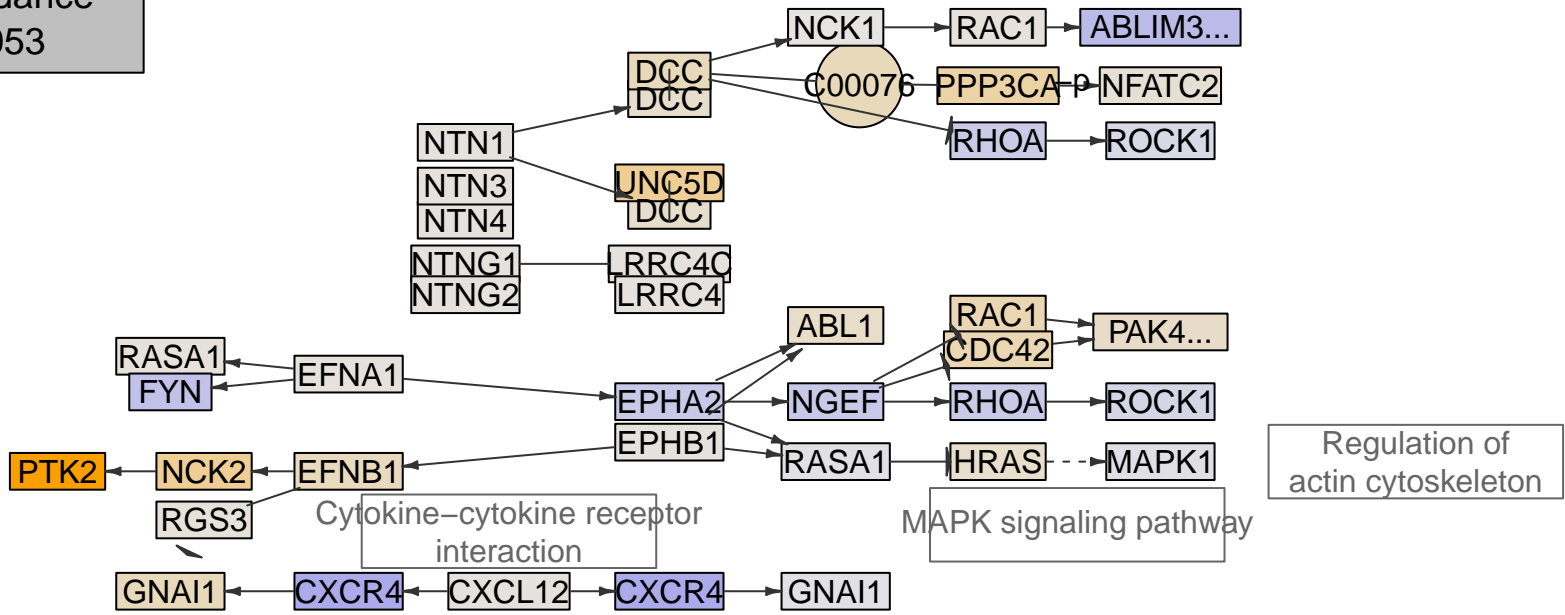

Regulation of actin cytoskeleton

MAPK signaling pathway

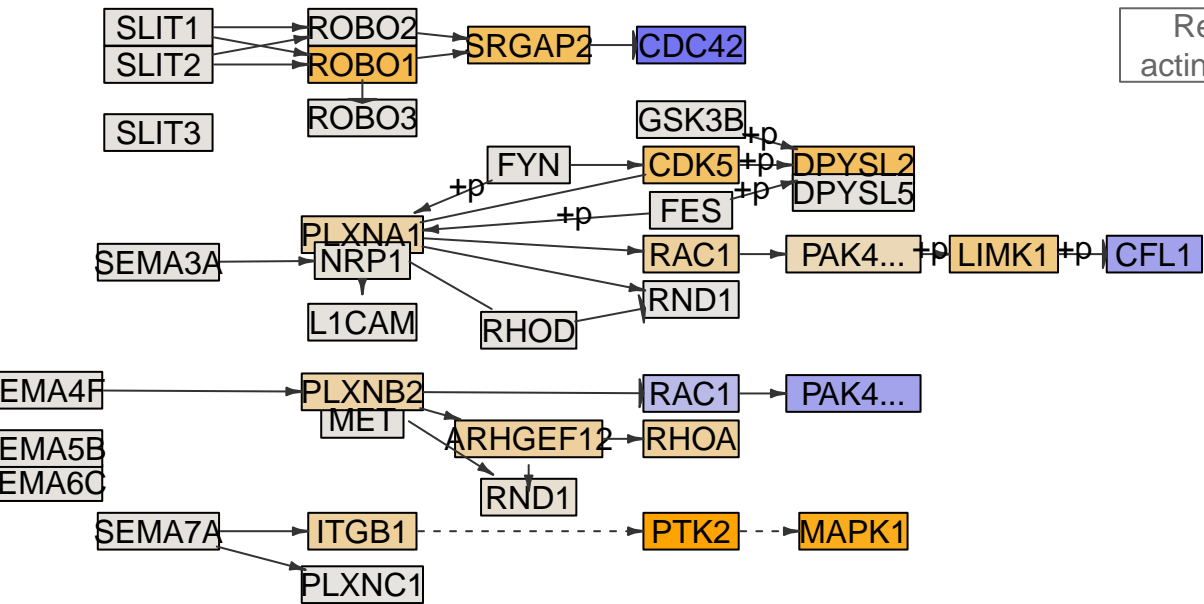

Regulation of actin cytoskeleton

Regulation of actin cytoskeleton

Axon guidance
MPI-062

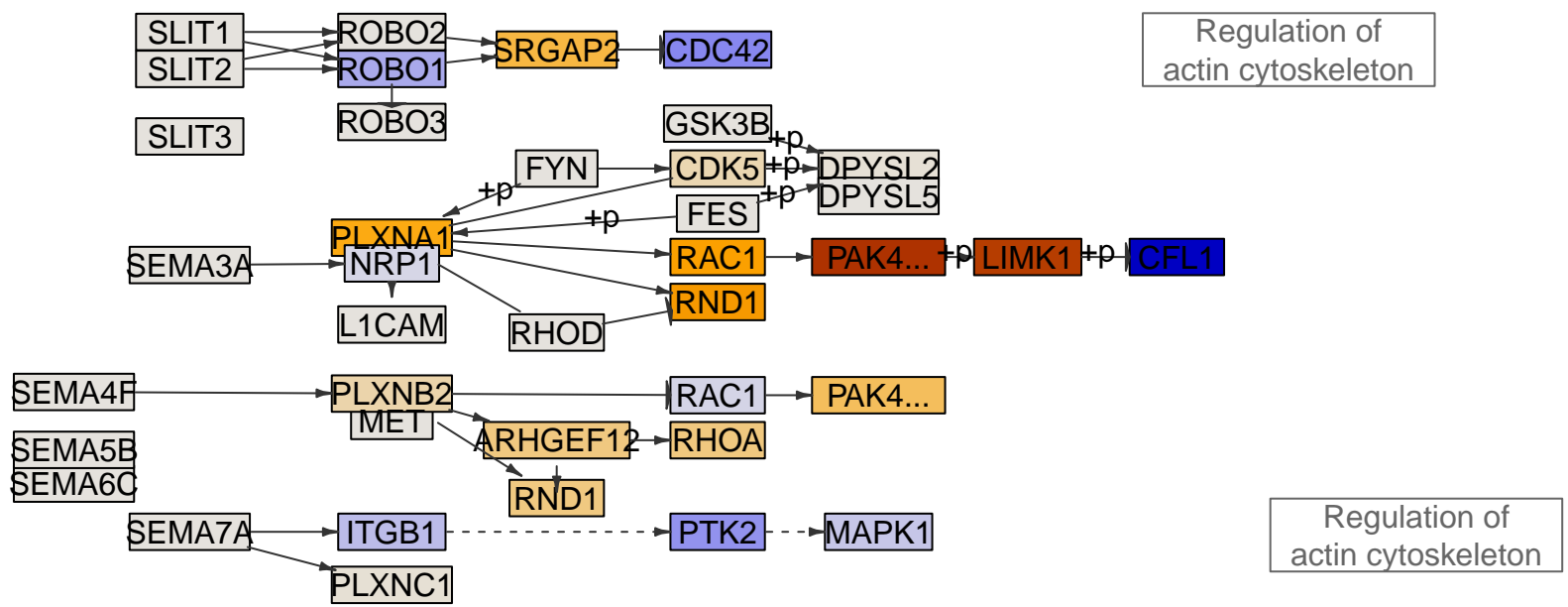
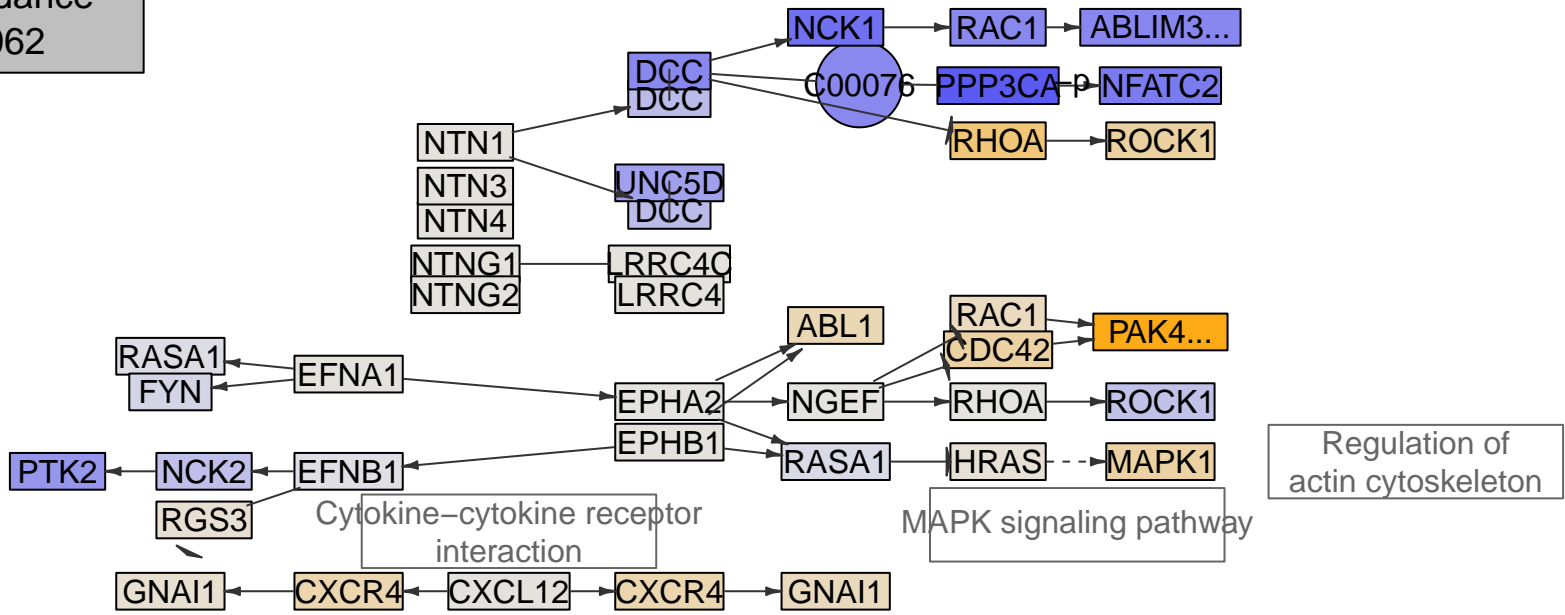

Axon guidance
MPI-063

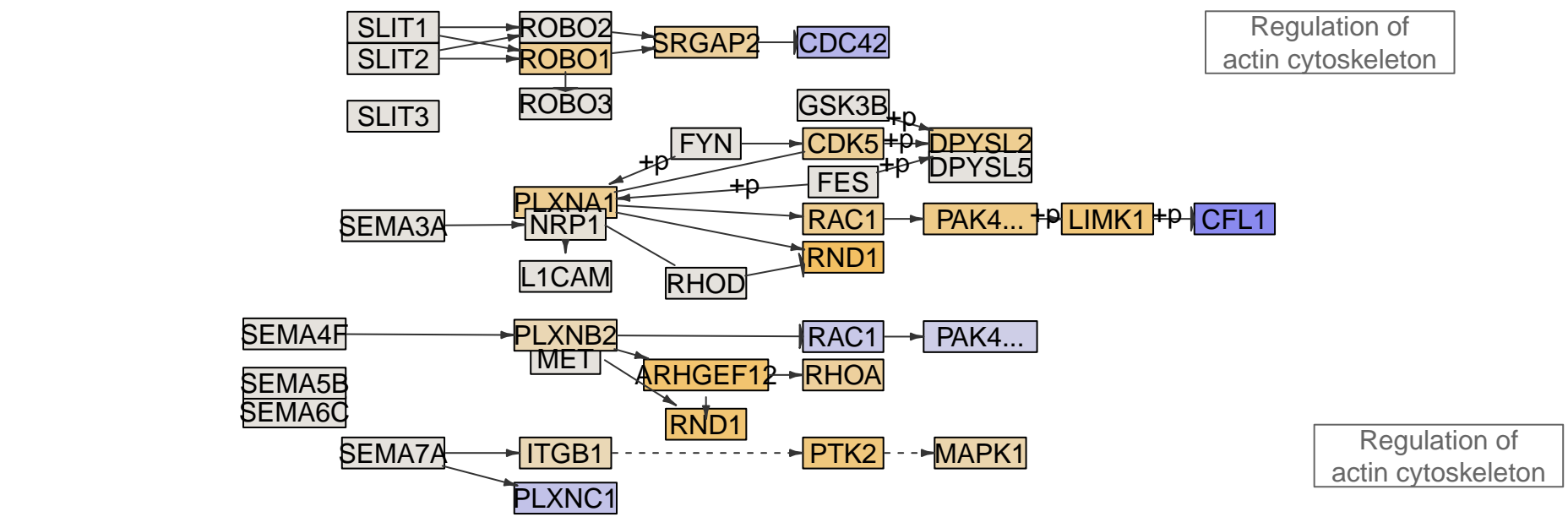
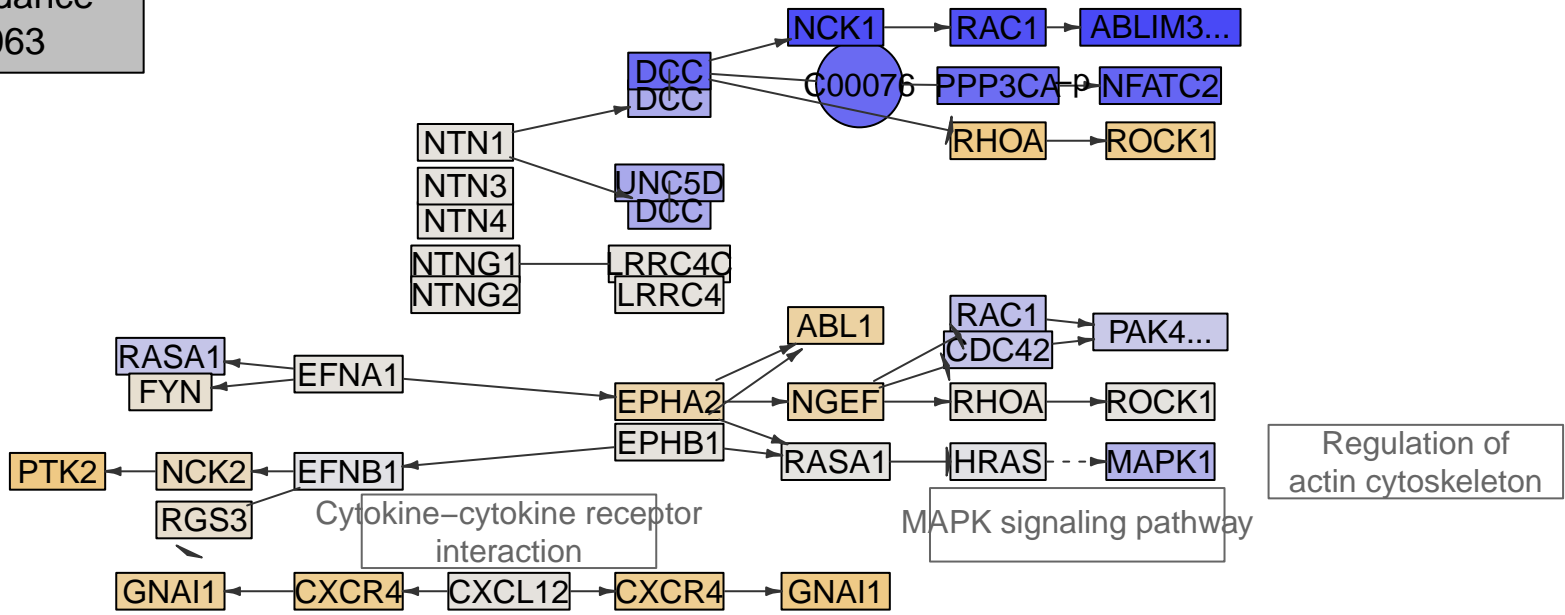

Axon guidance
MPI-069

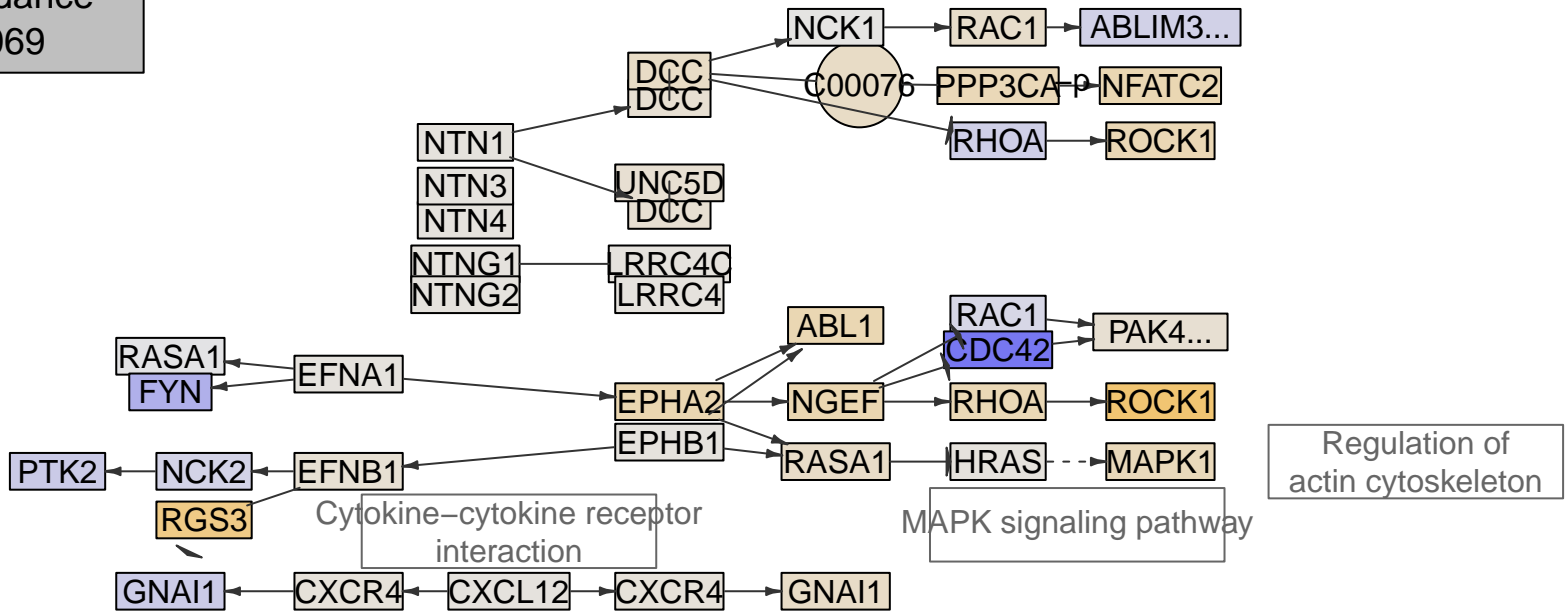

Regulation of actin cytoskeleton

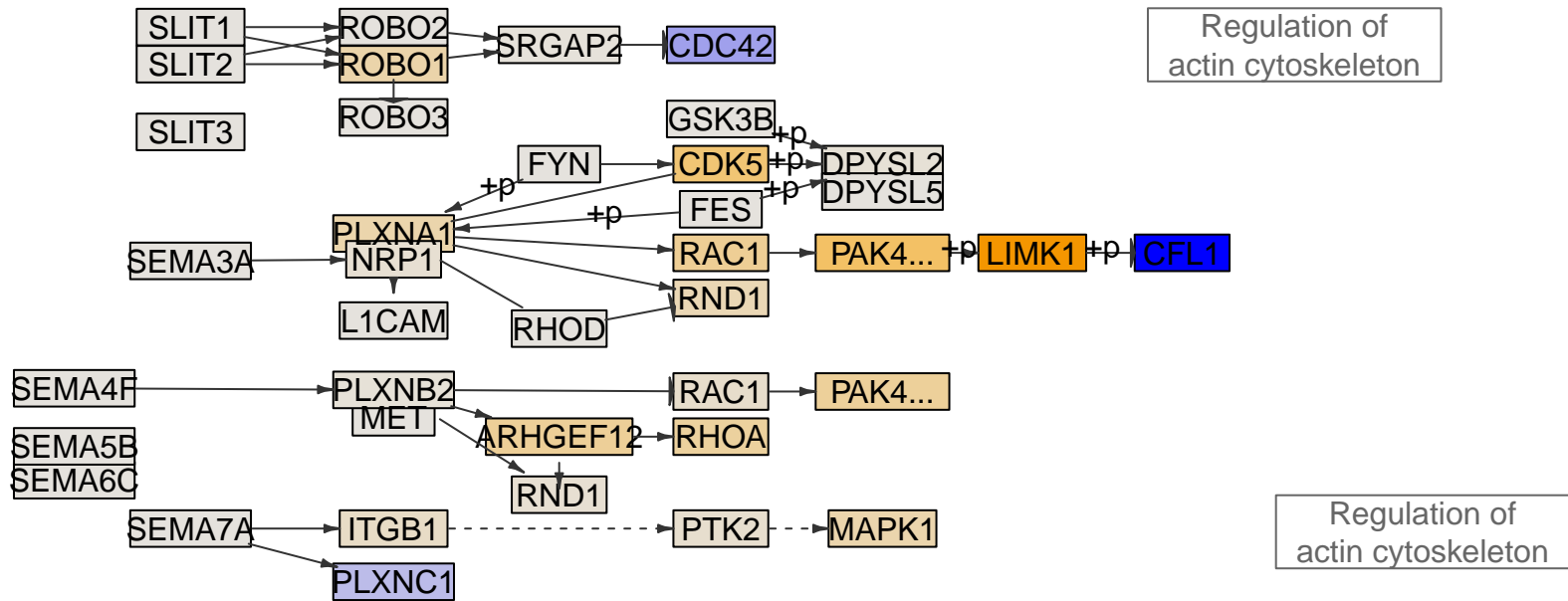

Regulation of actin cytoskeleton

Regulation of actin cytoskeleton

Axon guidance
MPI-073

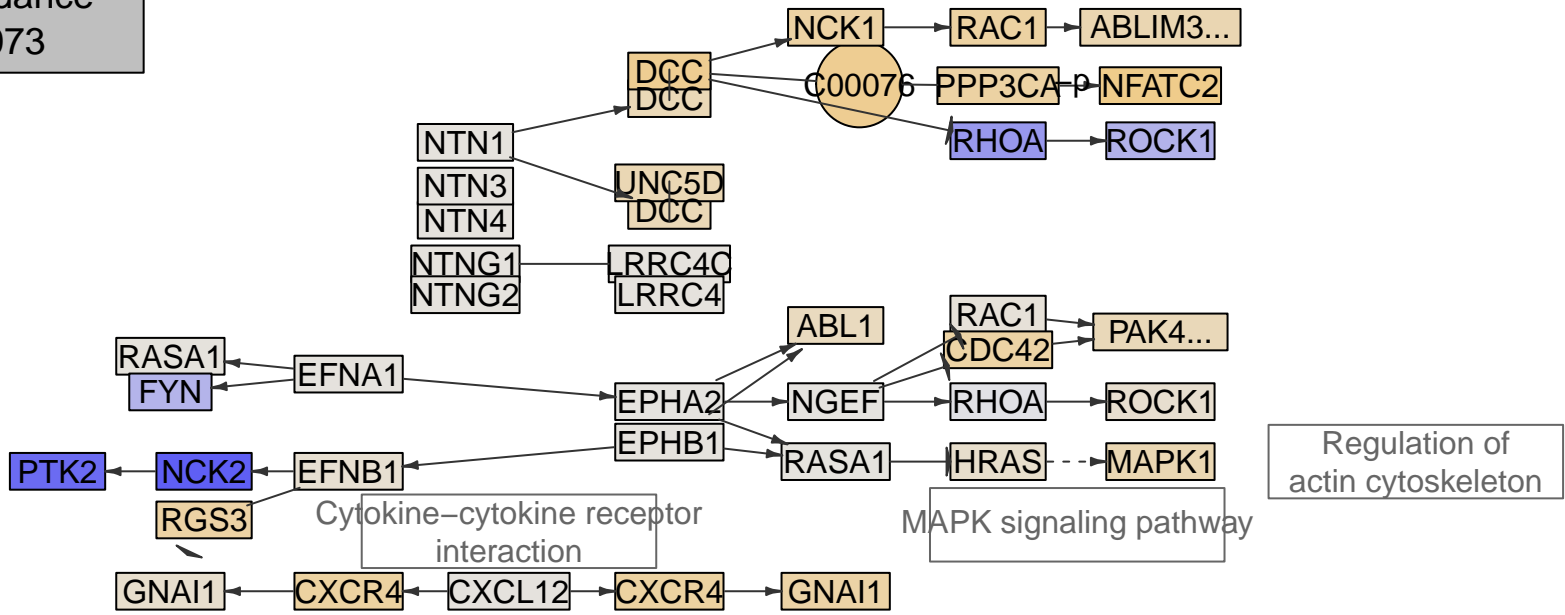

Regulation of actin cytoskeleton

MAPK signaling pathway

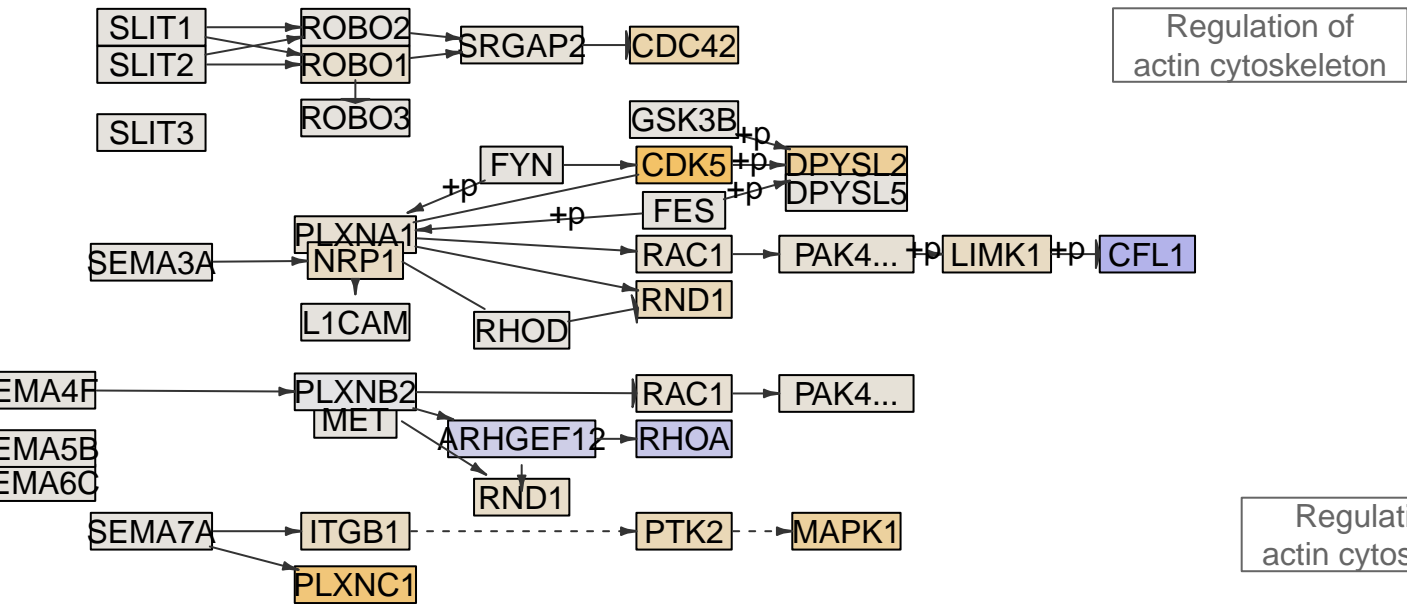

Regulation of actin cytoskeleton

Regulation of actin cytoskeleton

Axon guidance
MPI-074

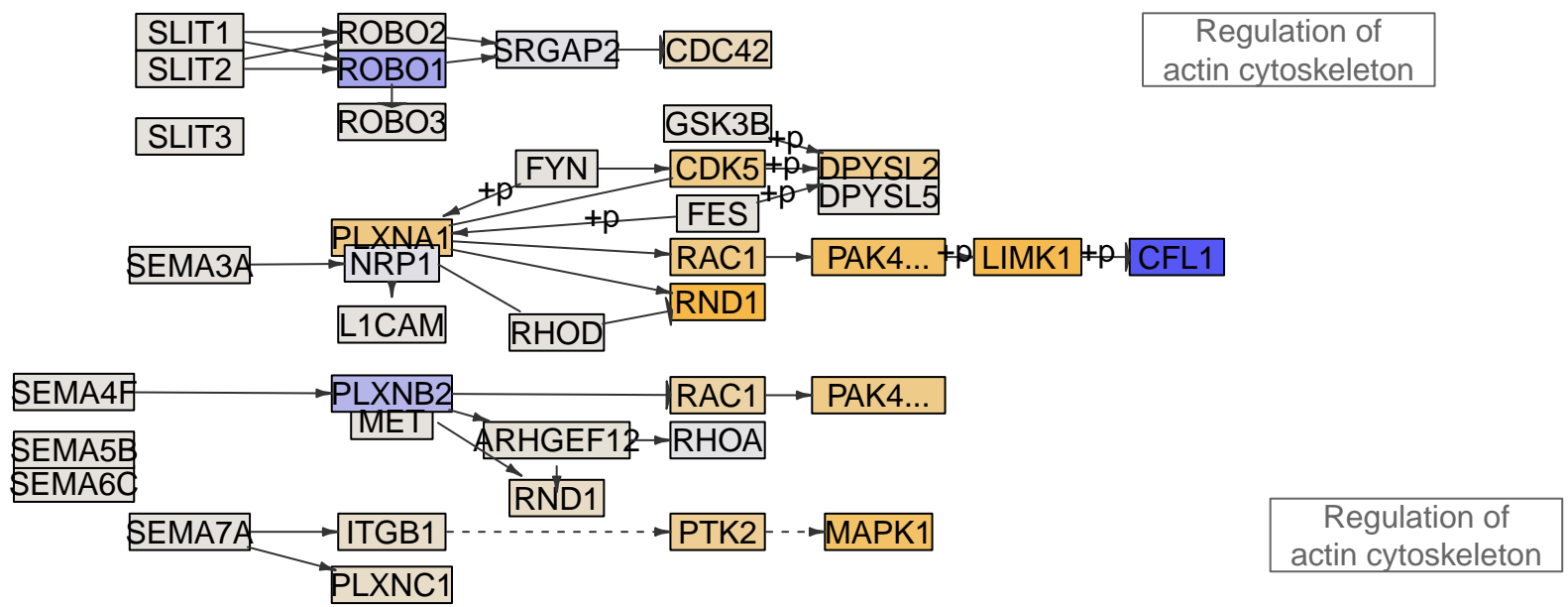
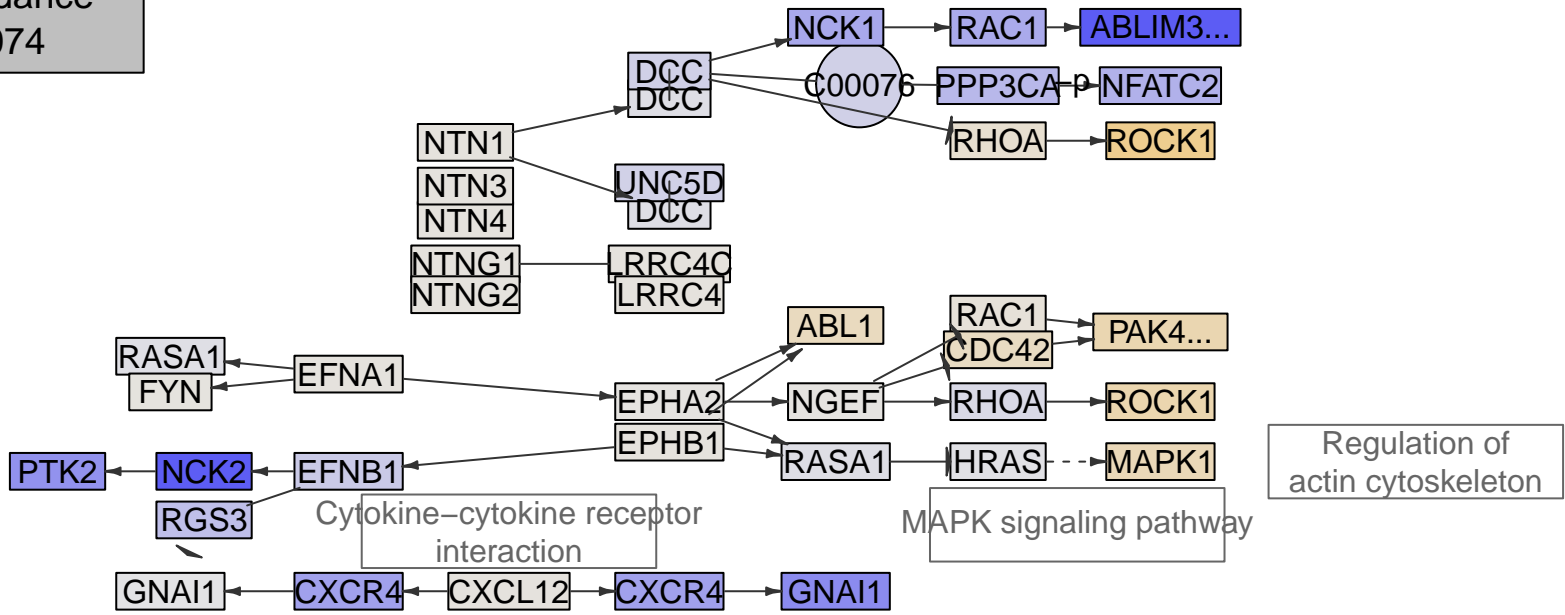

Axon guidance
MPI-076

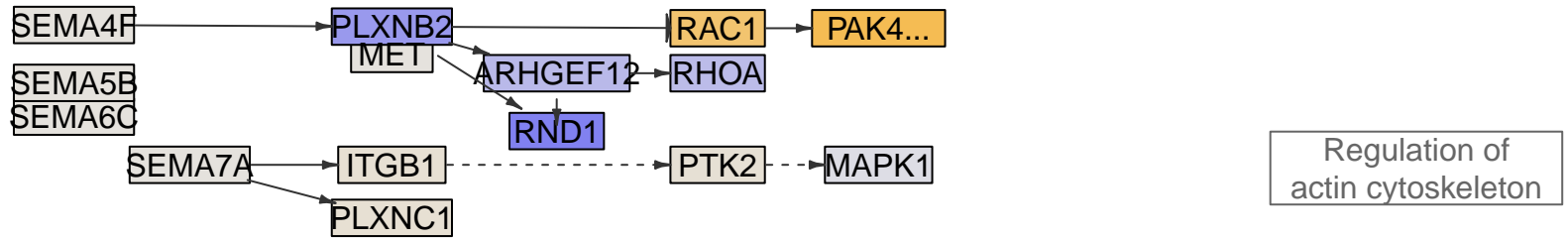
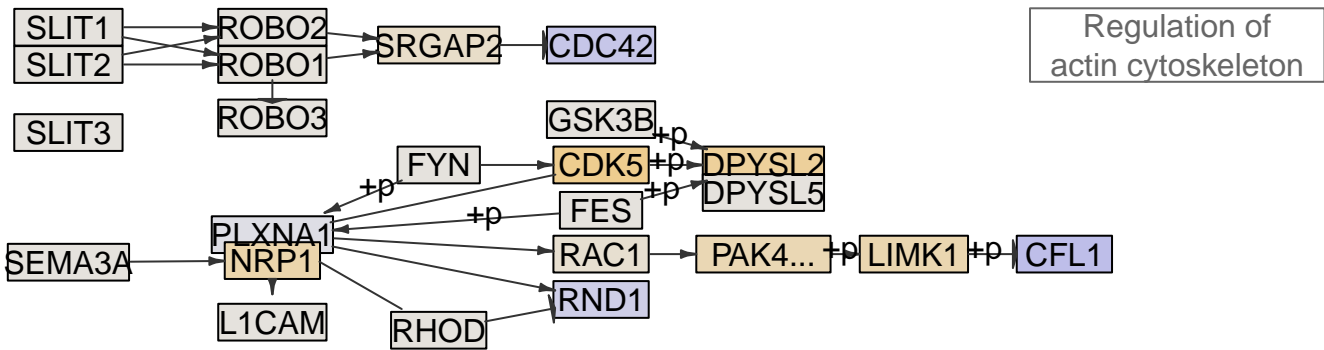
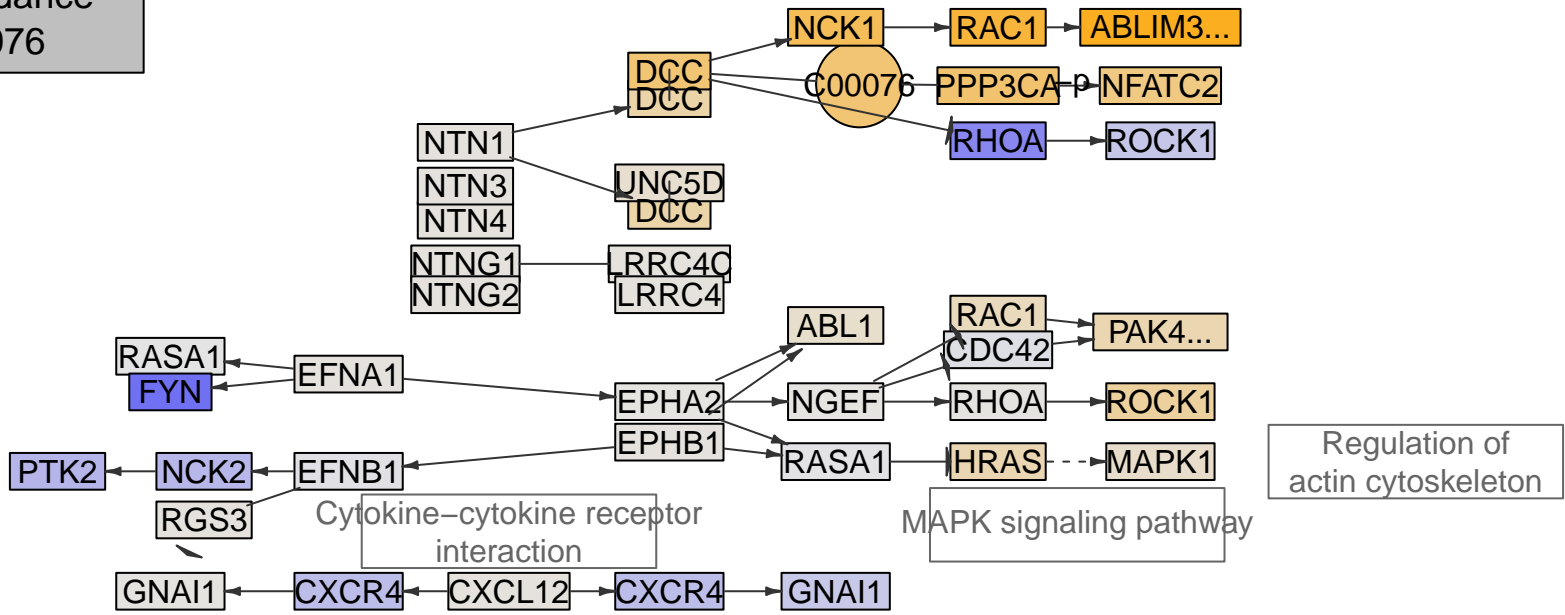

Axon guidance
MPI-083

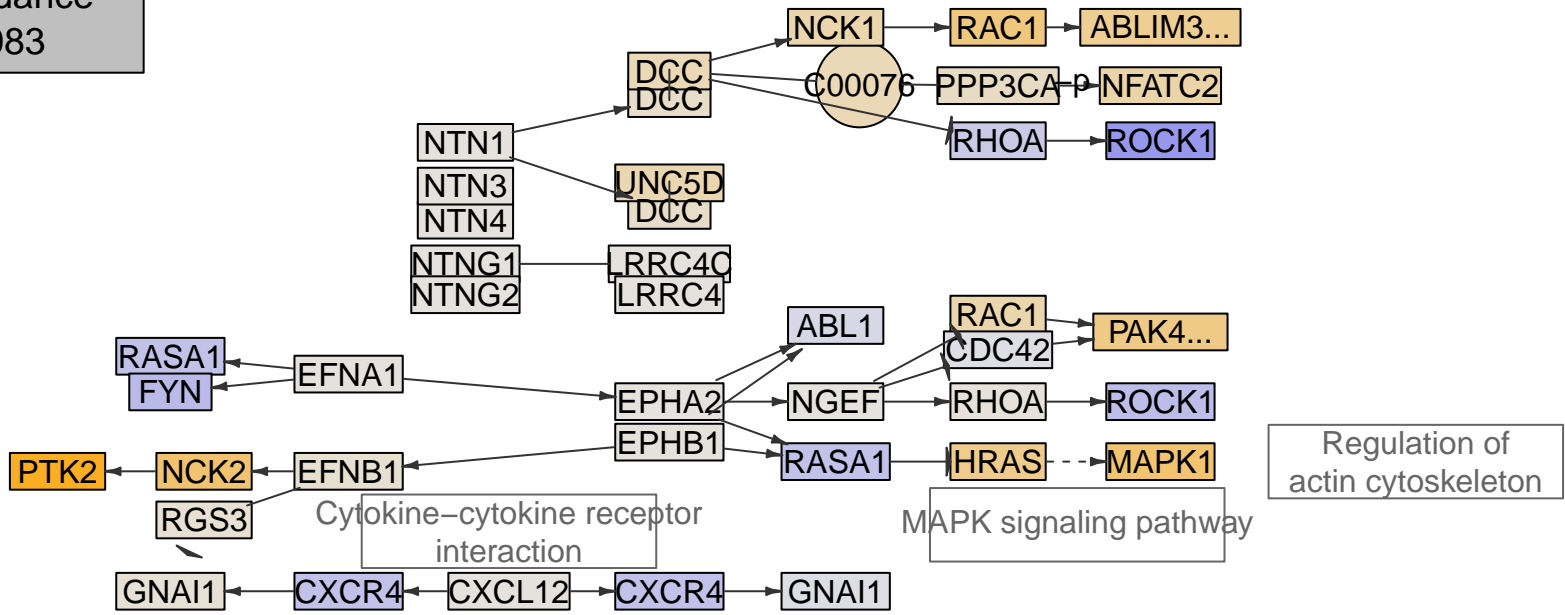

Regulation of actin cytoskeleton

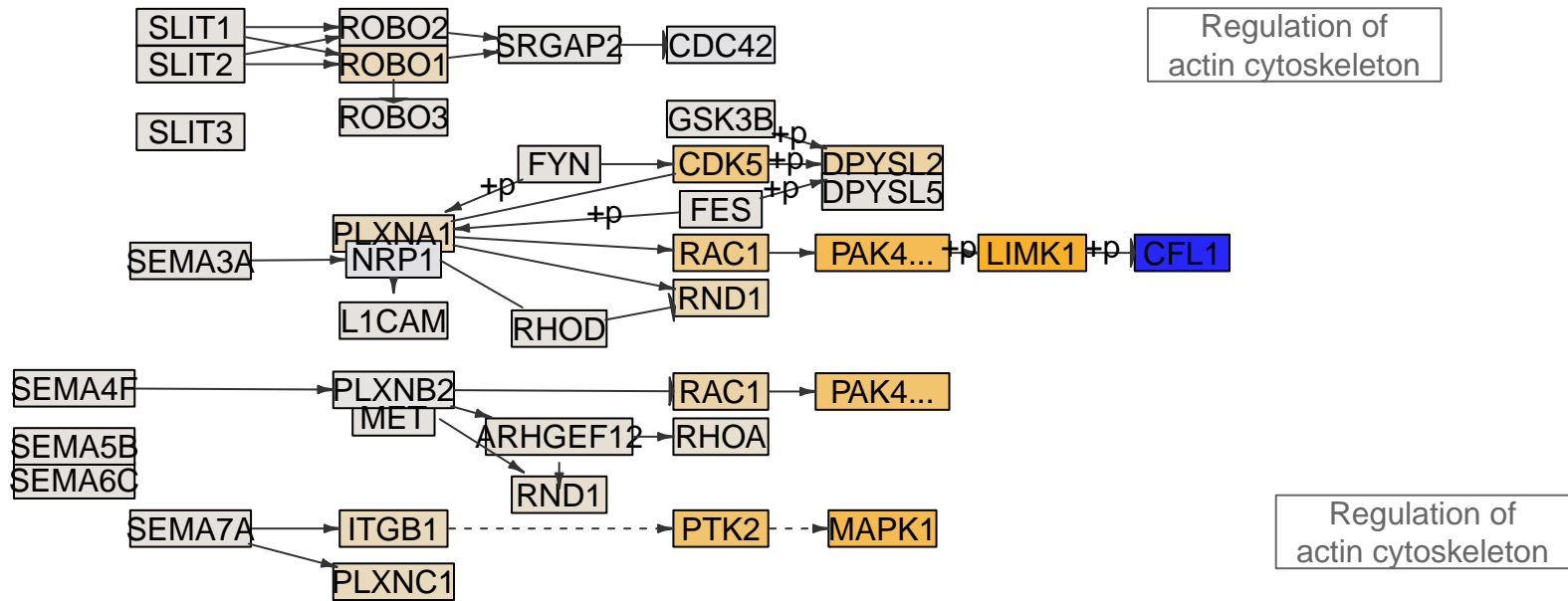

Regulation of actin cytoskeleton

Regulation of actin cytoskeleton

Axon guidance
MPI-088

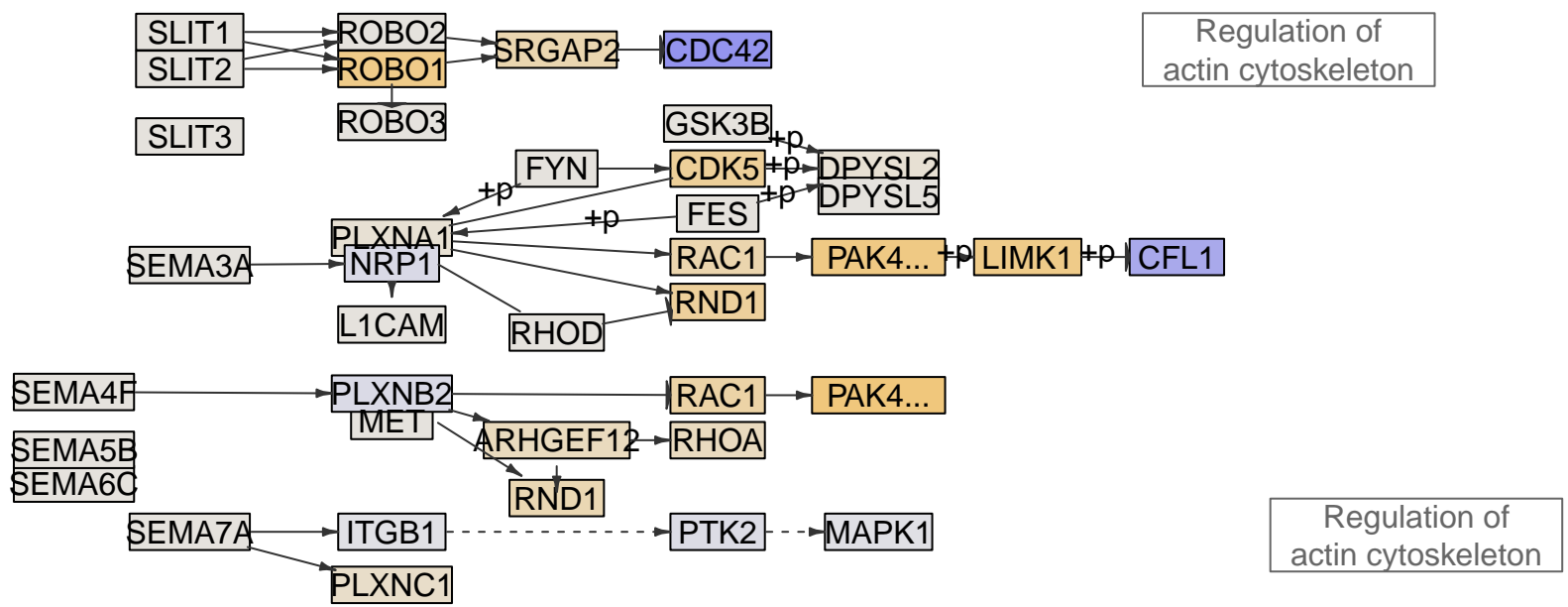
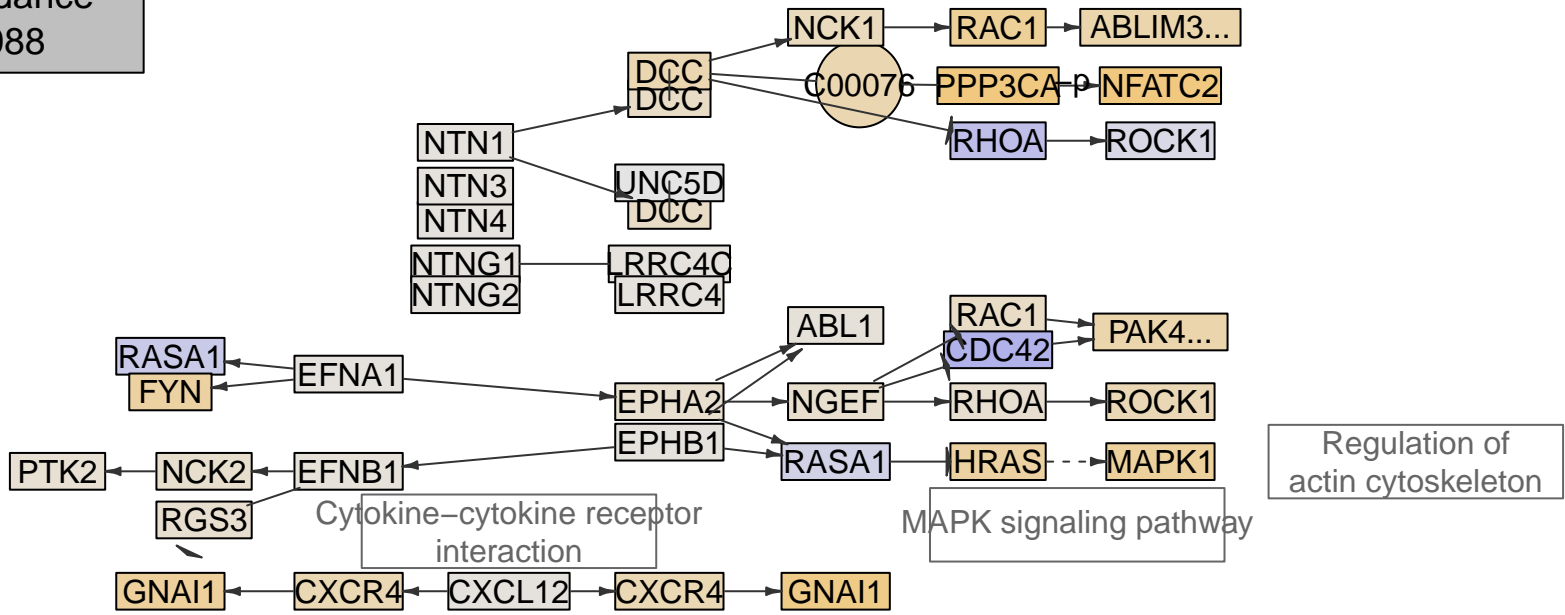

Axon guidance
MPI-092

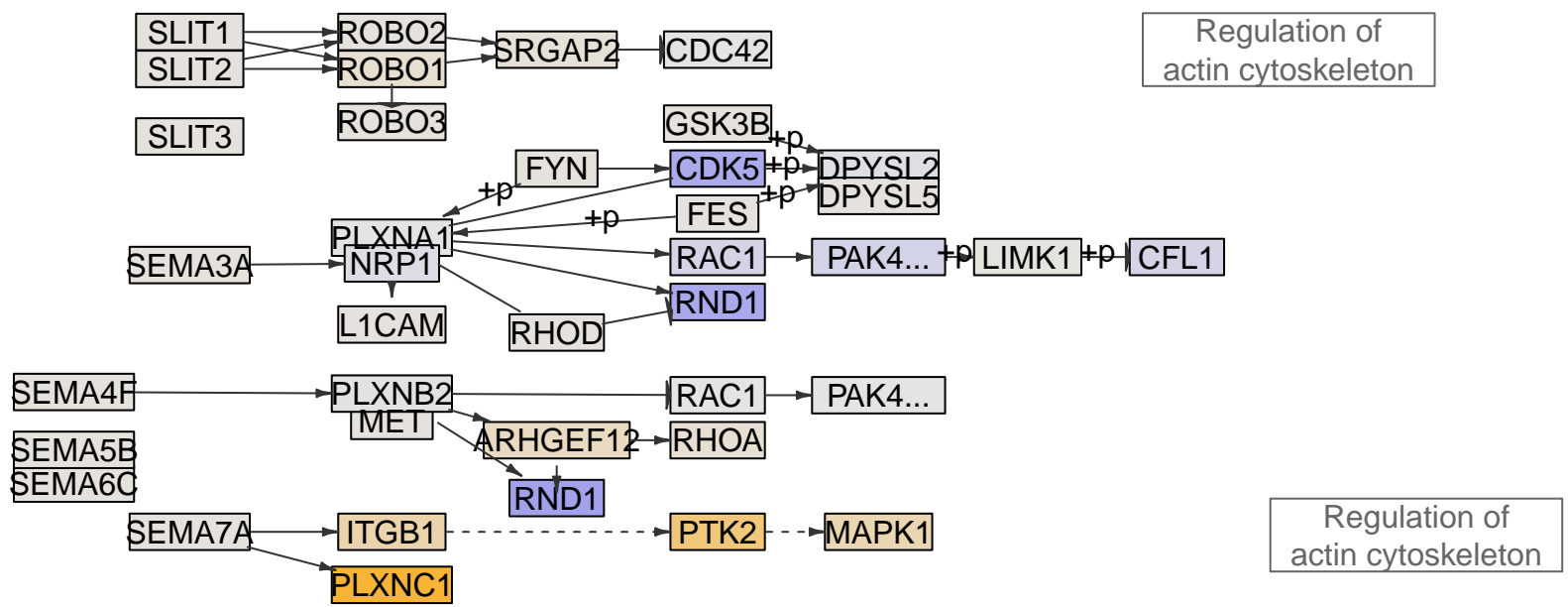
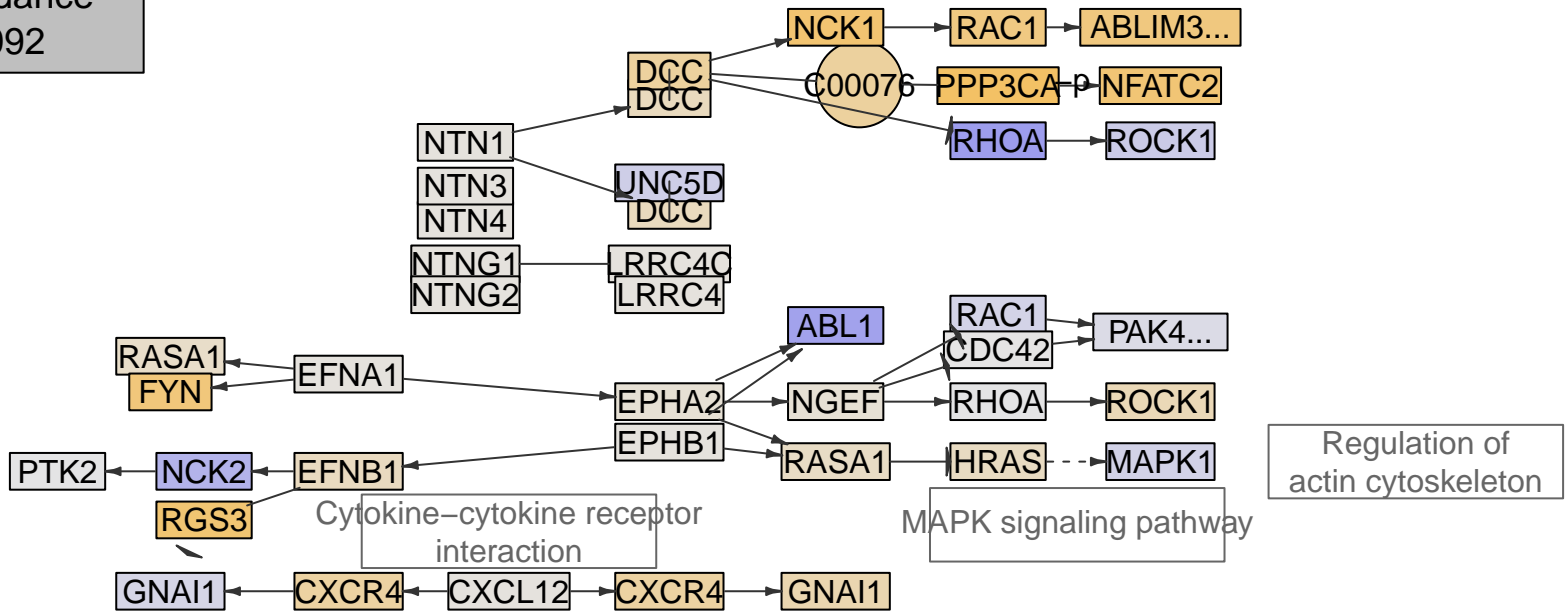

Axon guidance
MPI-096

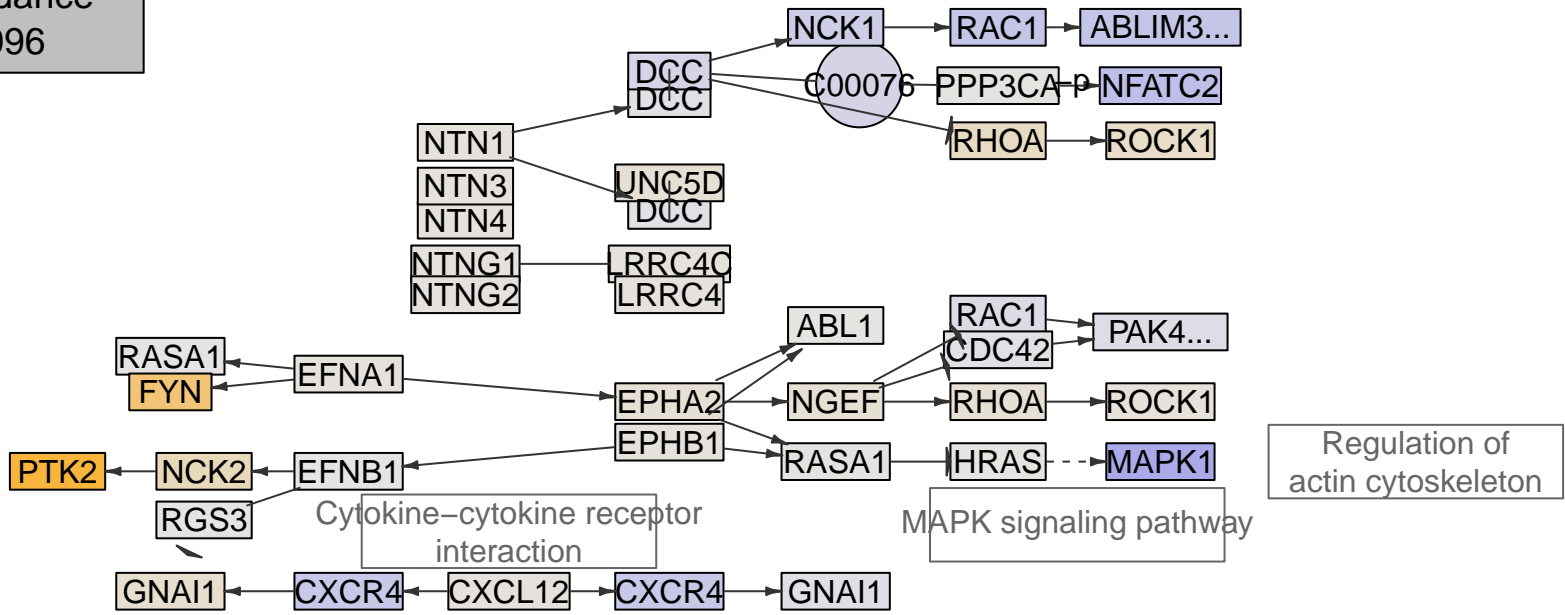

Regulation of actin cytoskeleton

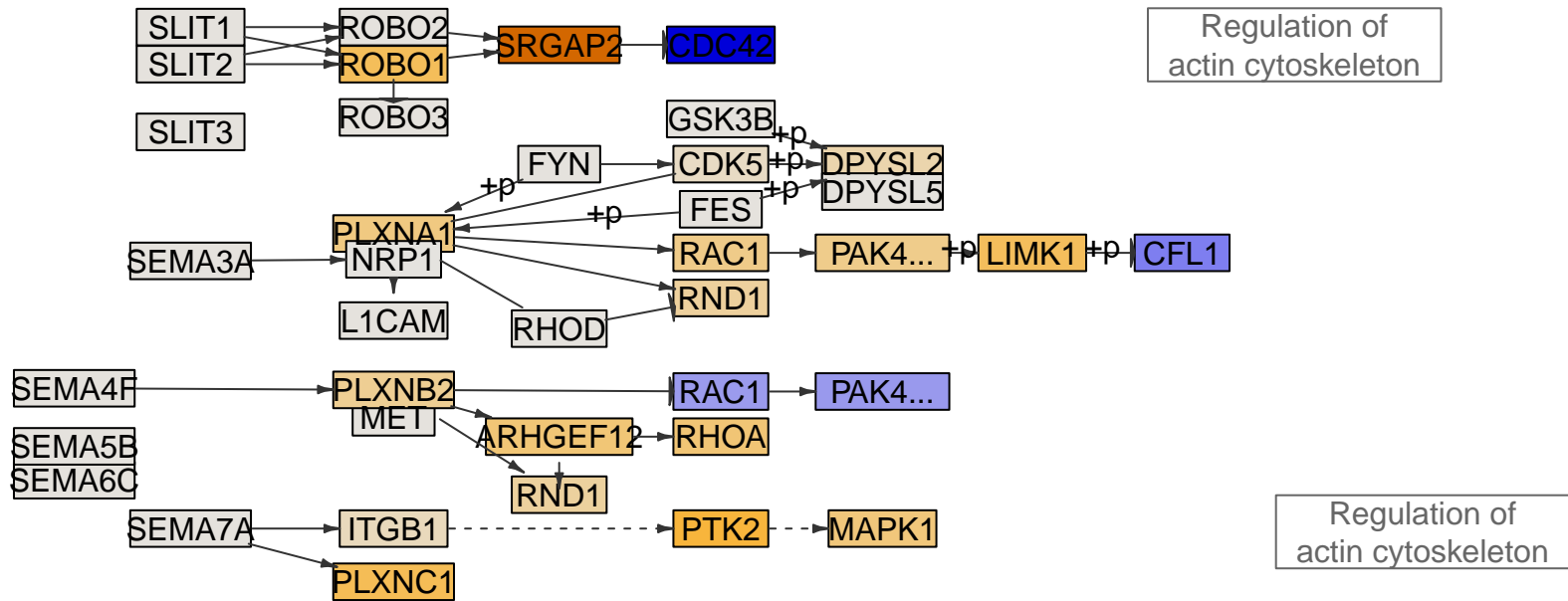

Regulation of actin cytoskeleton

Regulation of actin cytoskeleton

Axon guidance
MPI-098

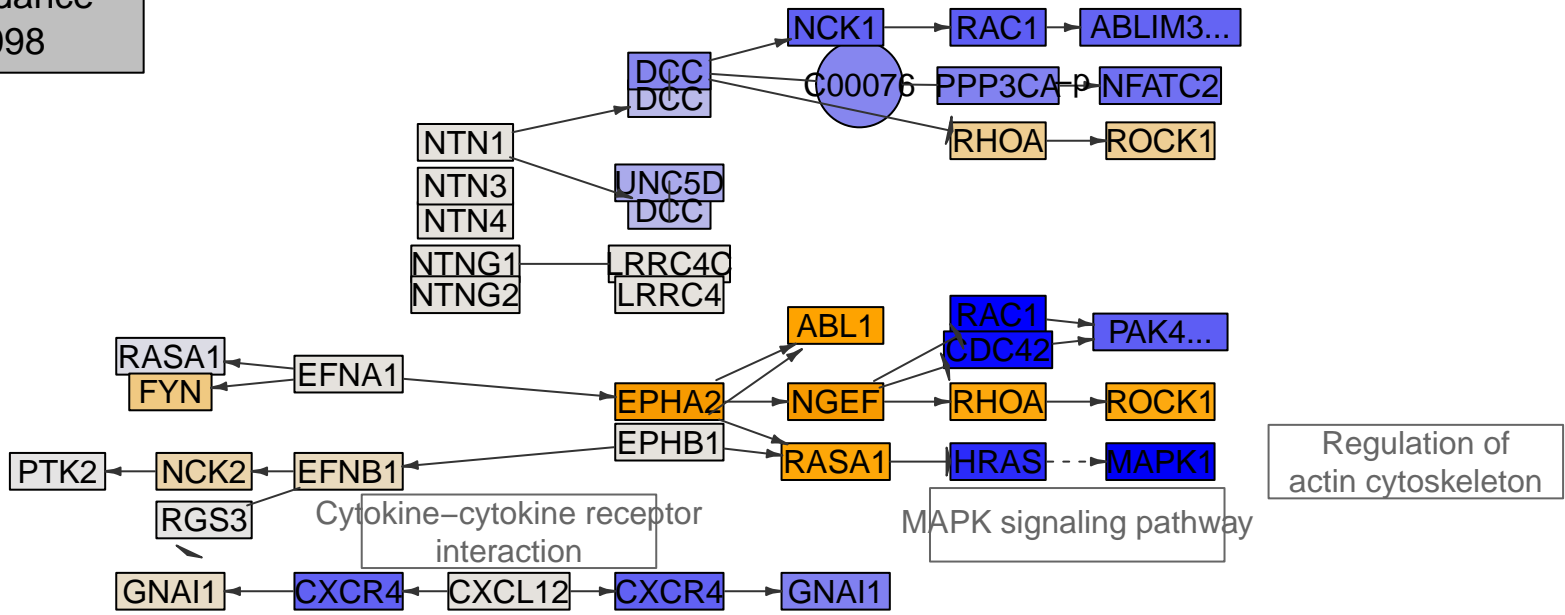

Regulation of actin cytoskeleton

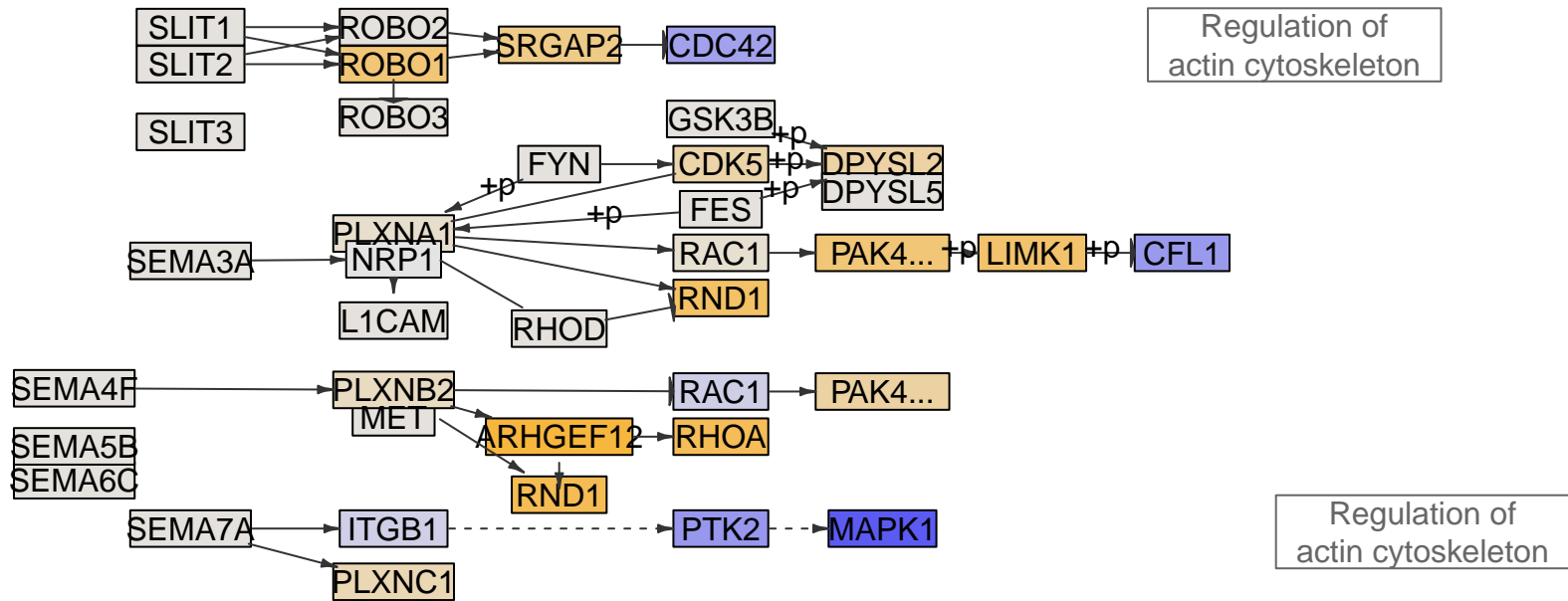

Regulation of actin cytoskeleton

Regulation of actin cytoskeleton

Axon guidance
MPI-100

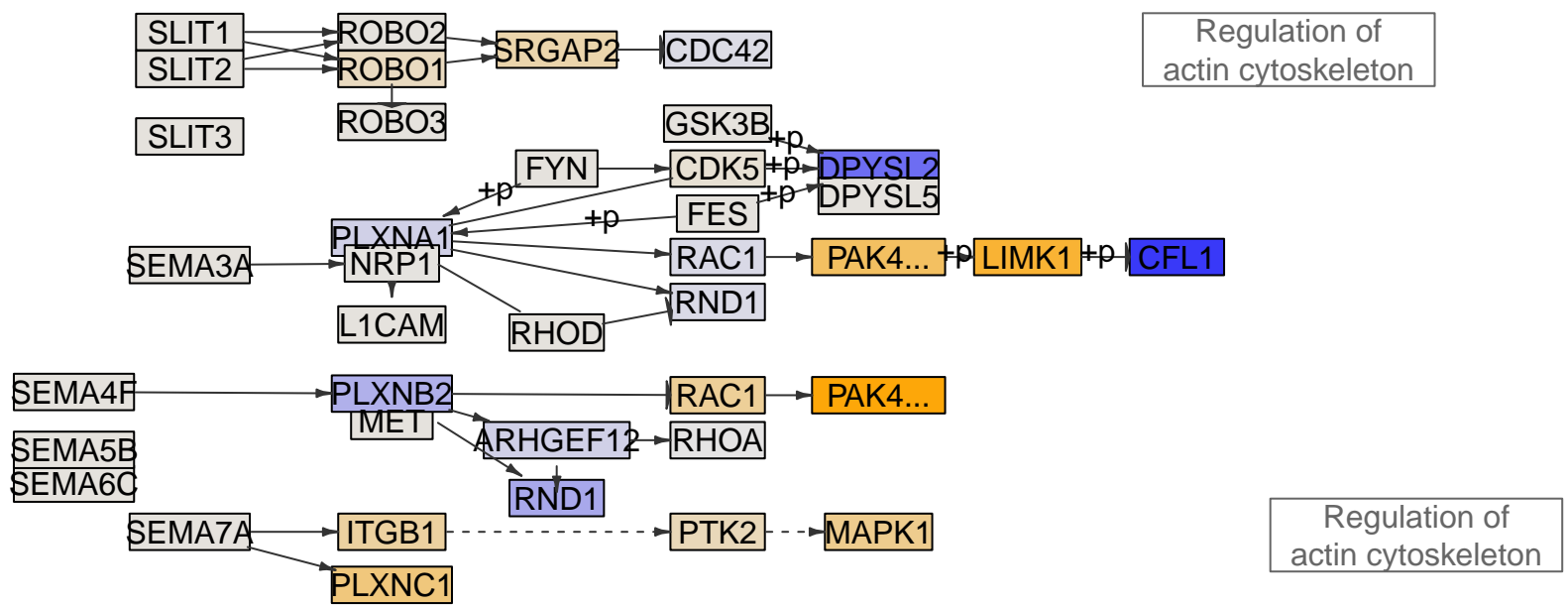
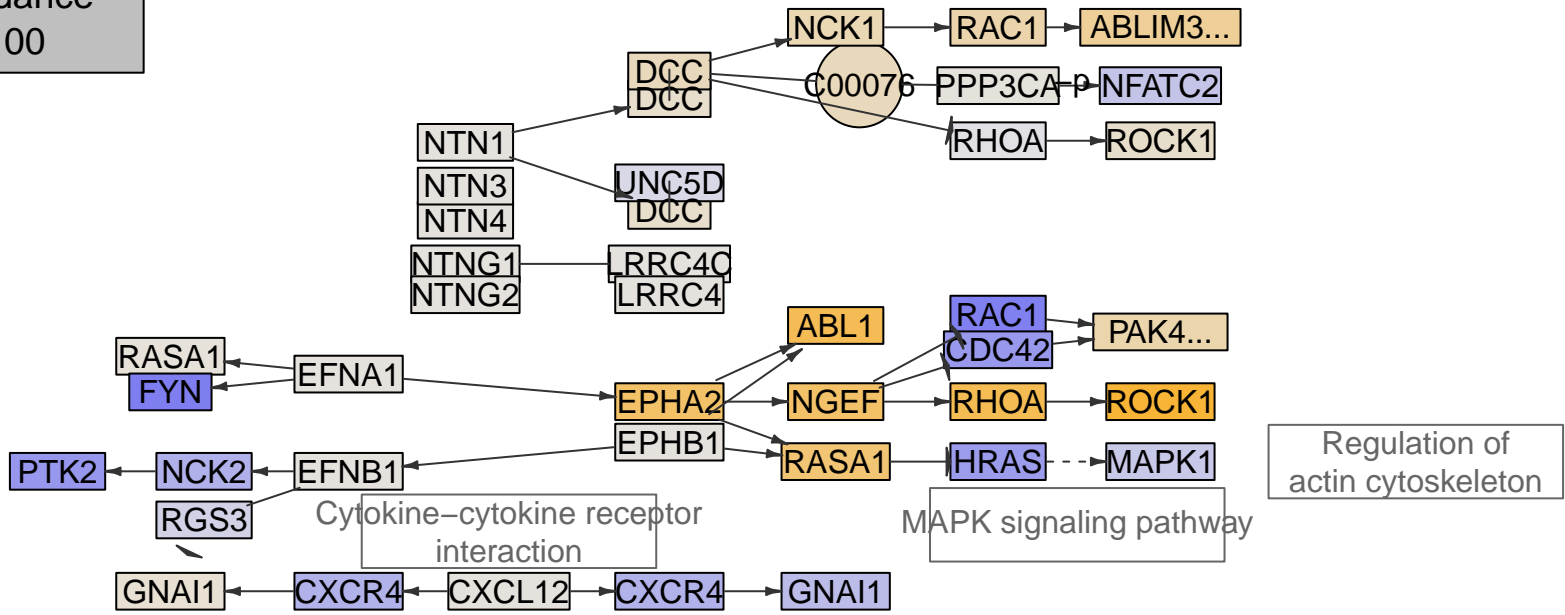

Axon guidance
MPI-105

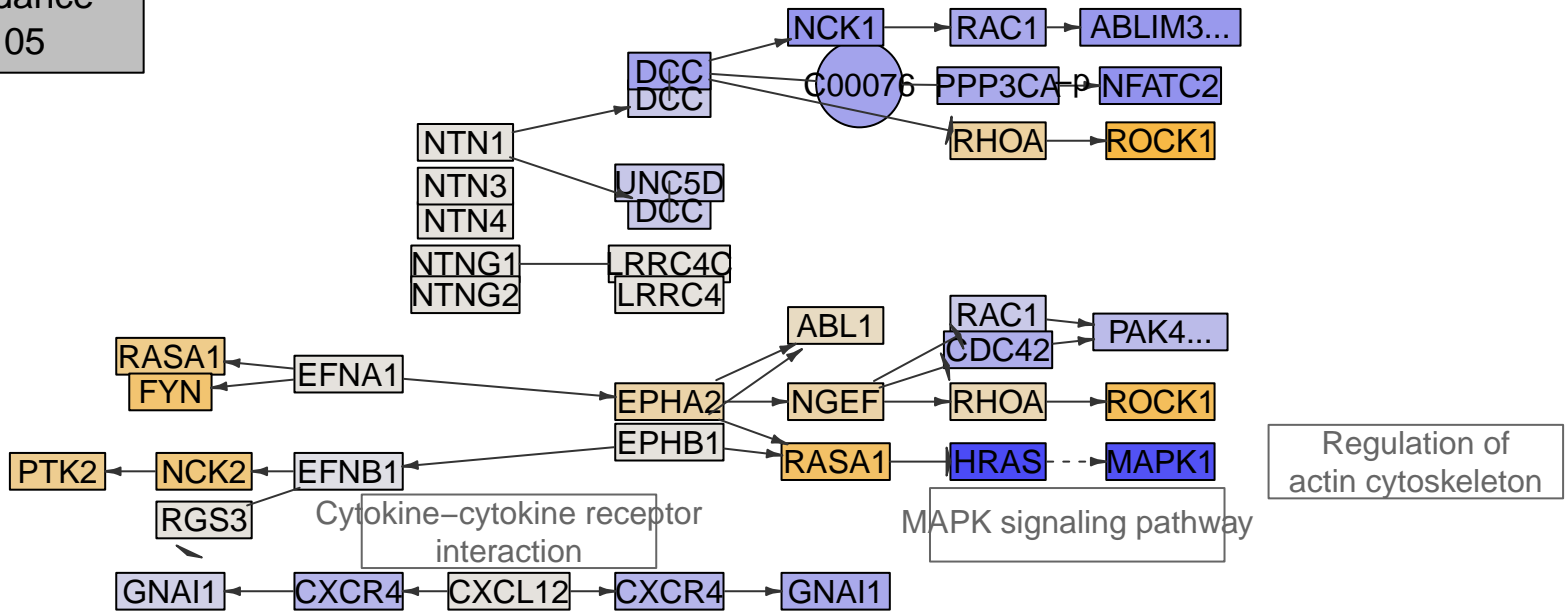

Regulation of actin cytoskeleton

MAPK signaling pathway

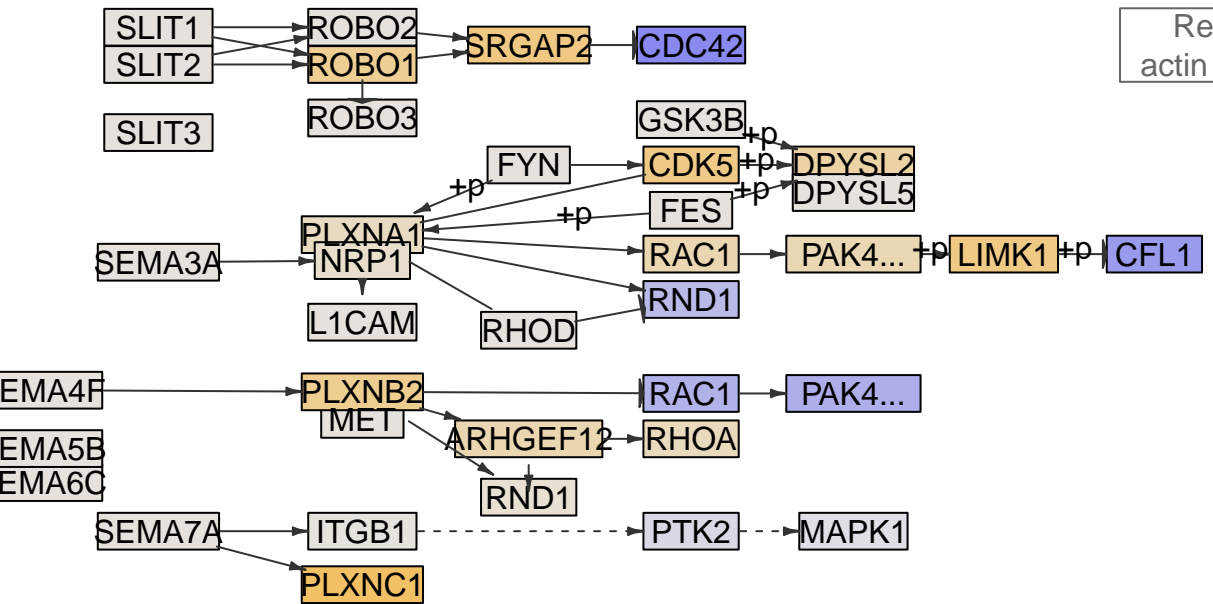

Regulation of actin cytoskeleton

Regulation of actin cytoskeleton

Axon guidance
MPI-106

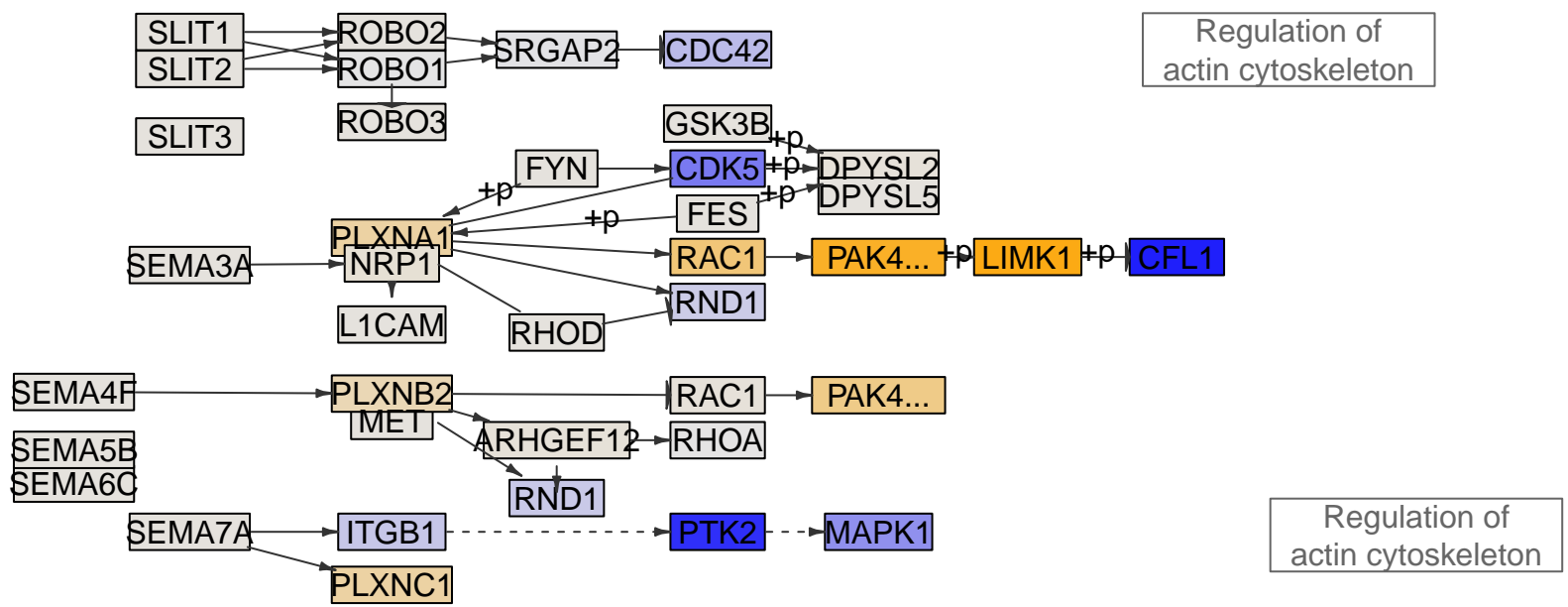
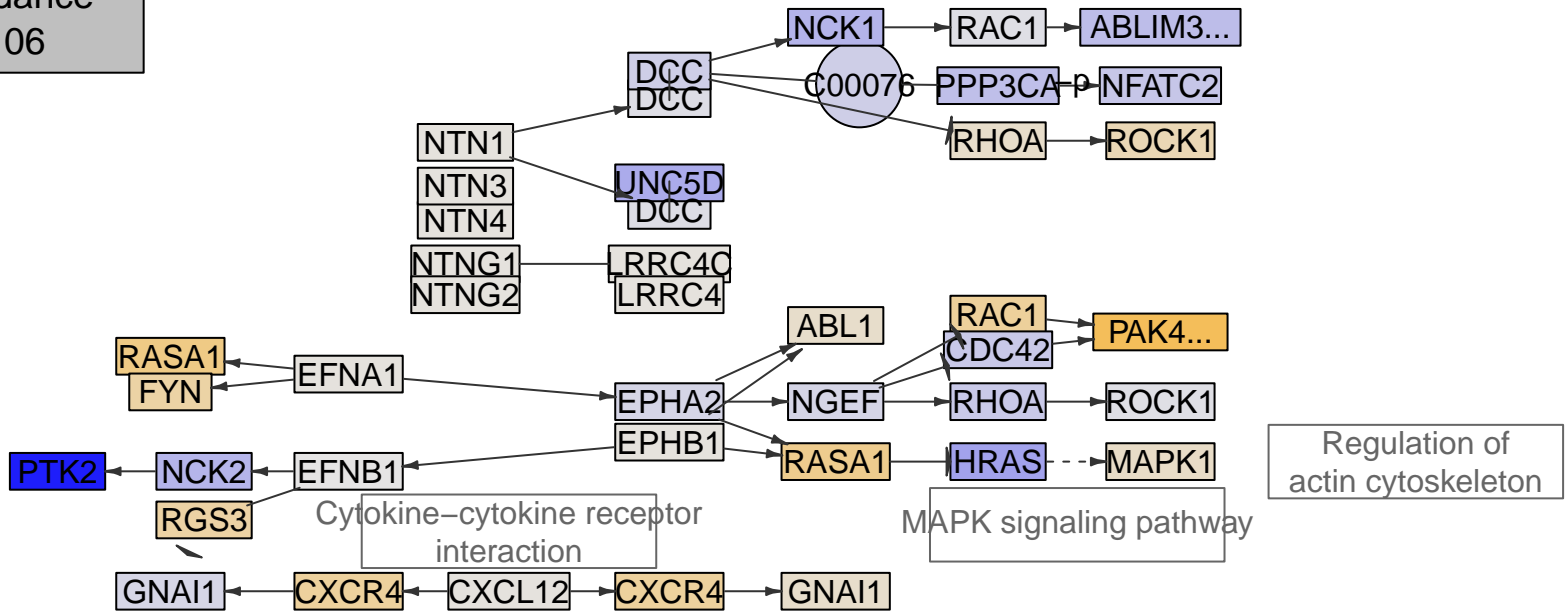

Axon guidance
MPI-108

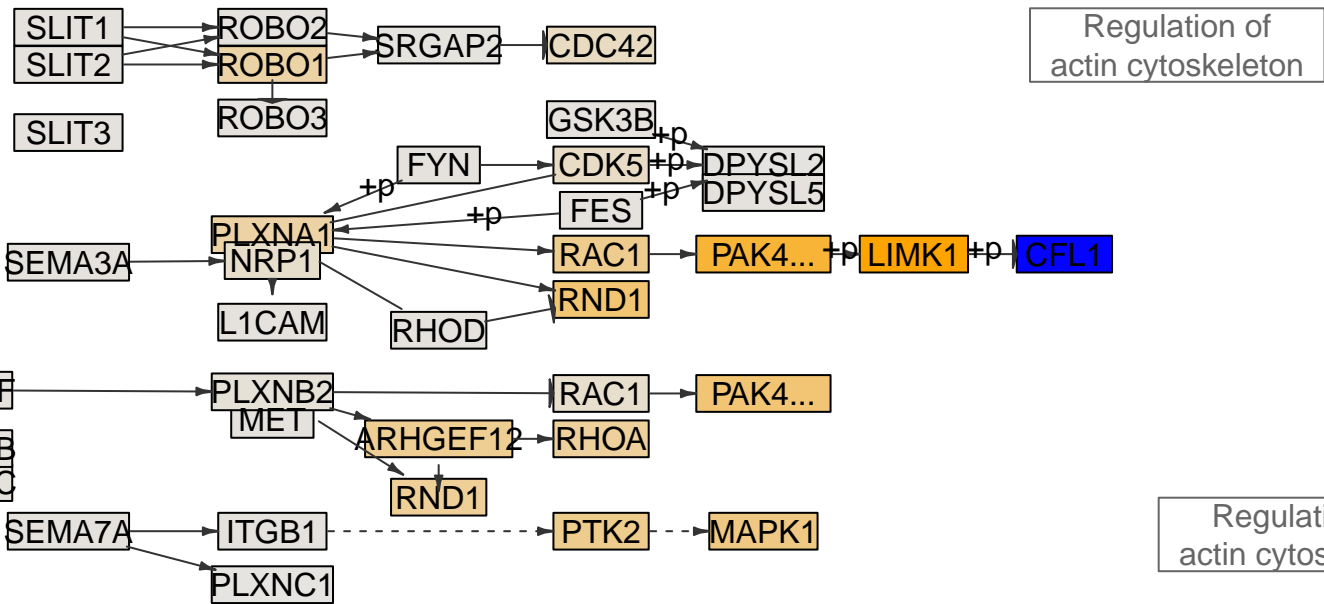
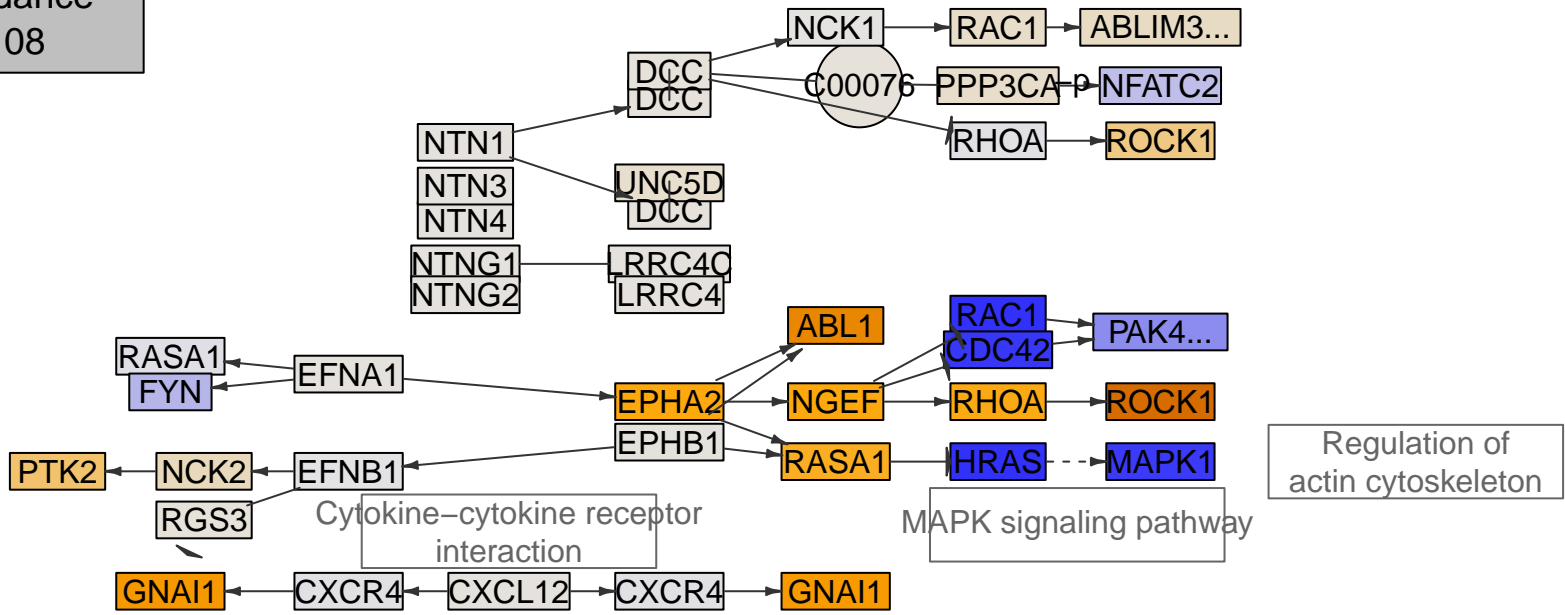

Axon guidance
MPI-109

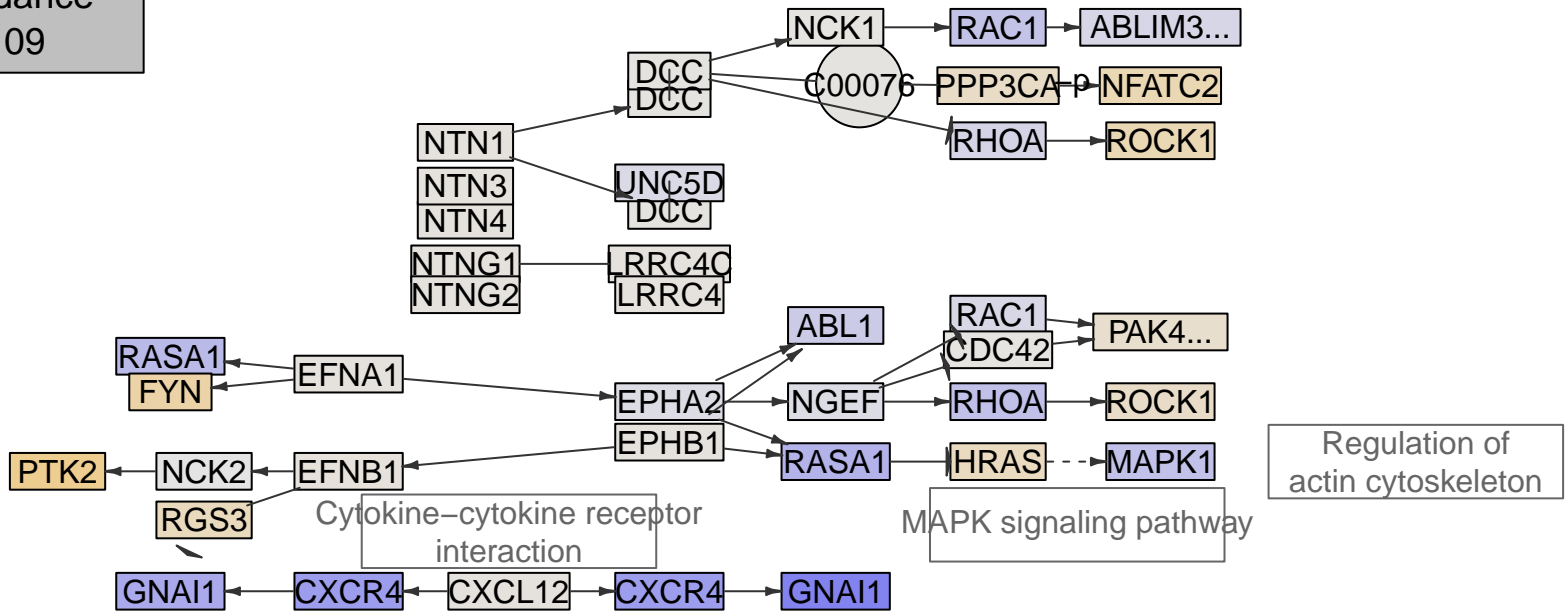

Regulation of actin cytoskeleton

MAPK signaling pathway

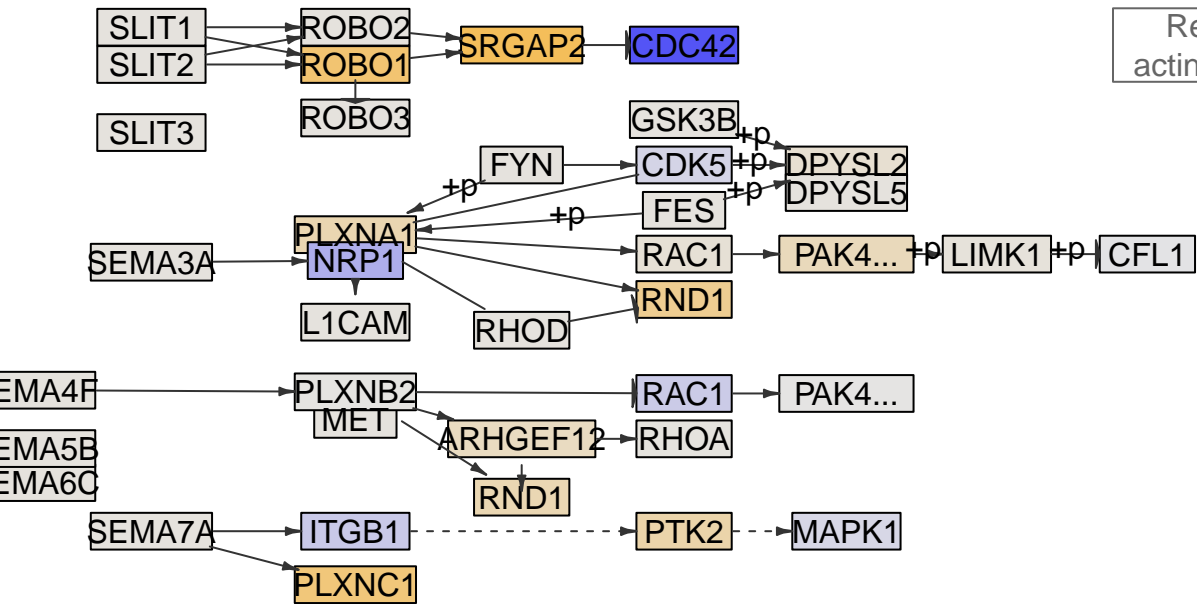

Regulation of actin cytoskeleton

Regulation of actin cytoskeleton

Axon guidance
MPI-110

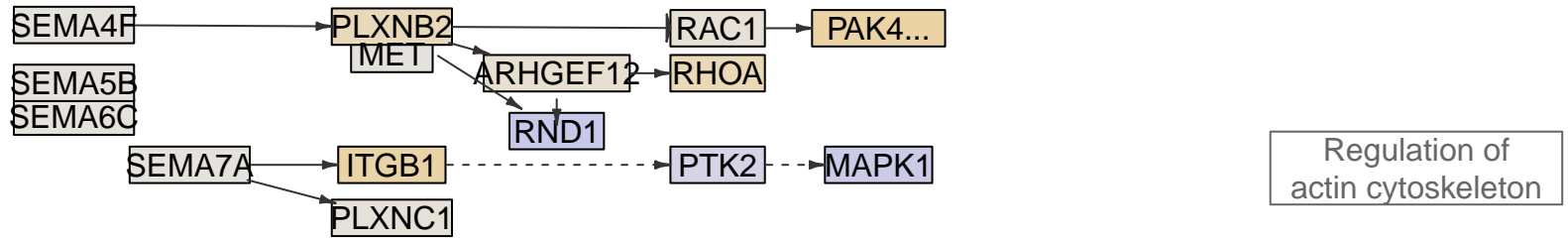
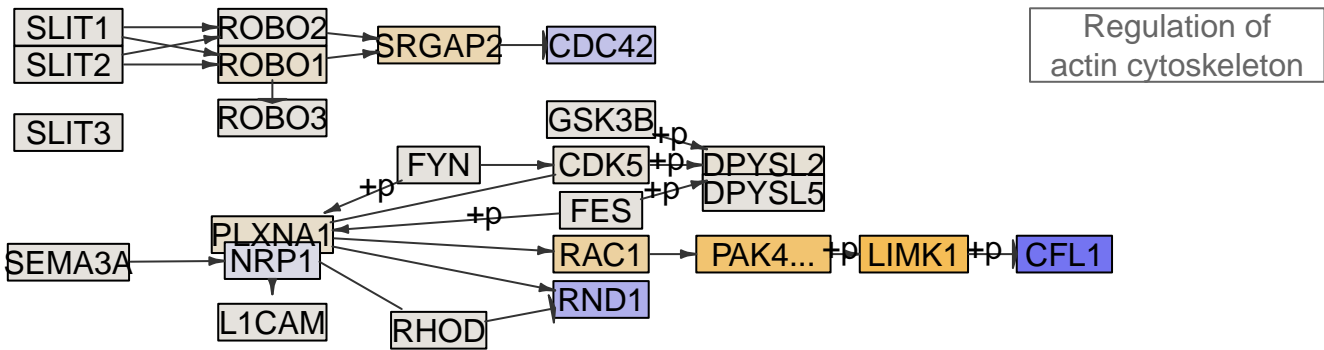
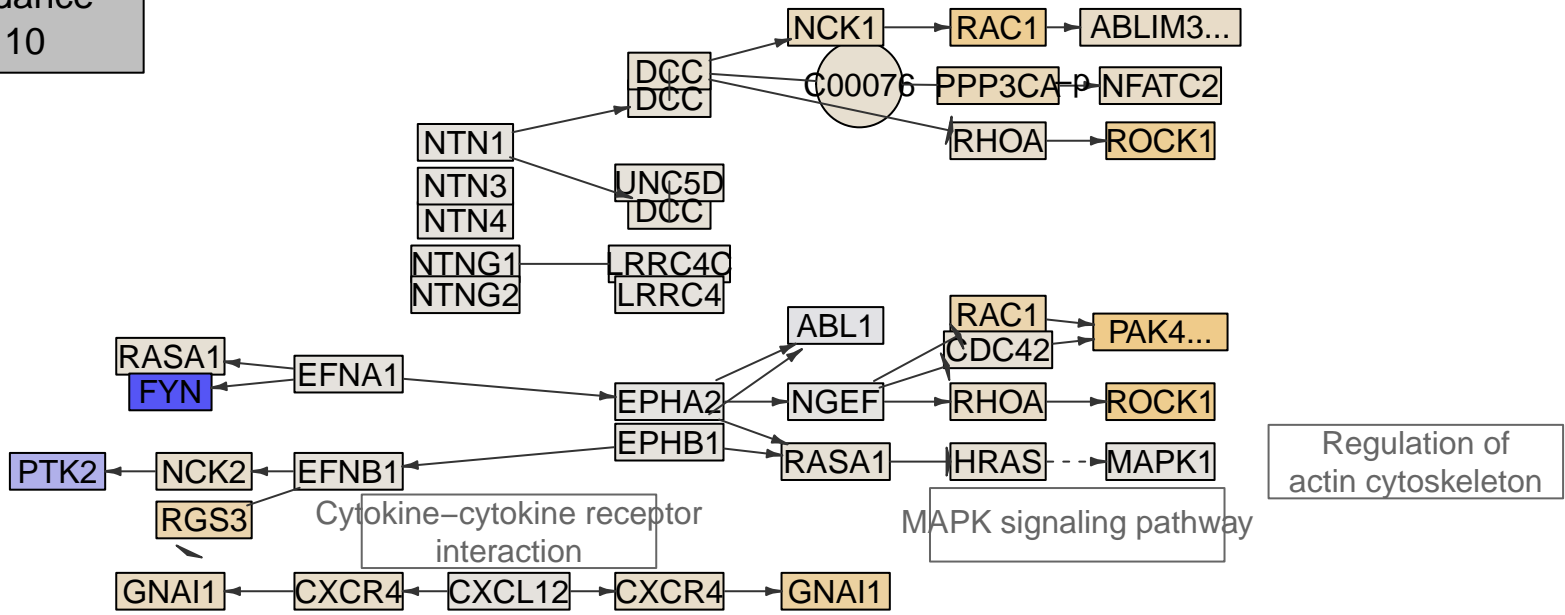

Axon guidance
MPI-111

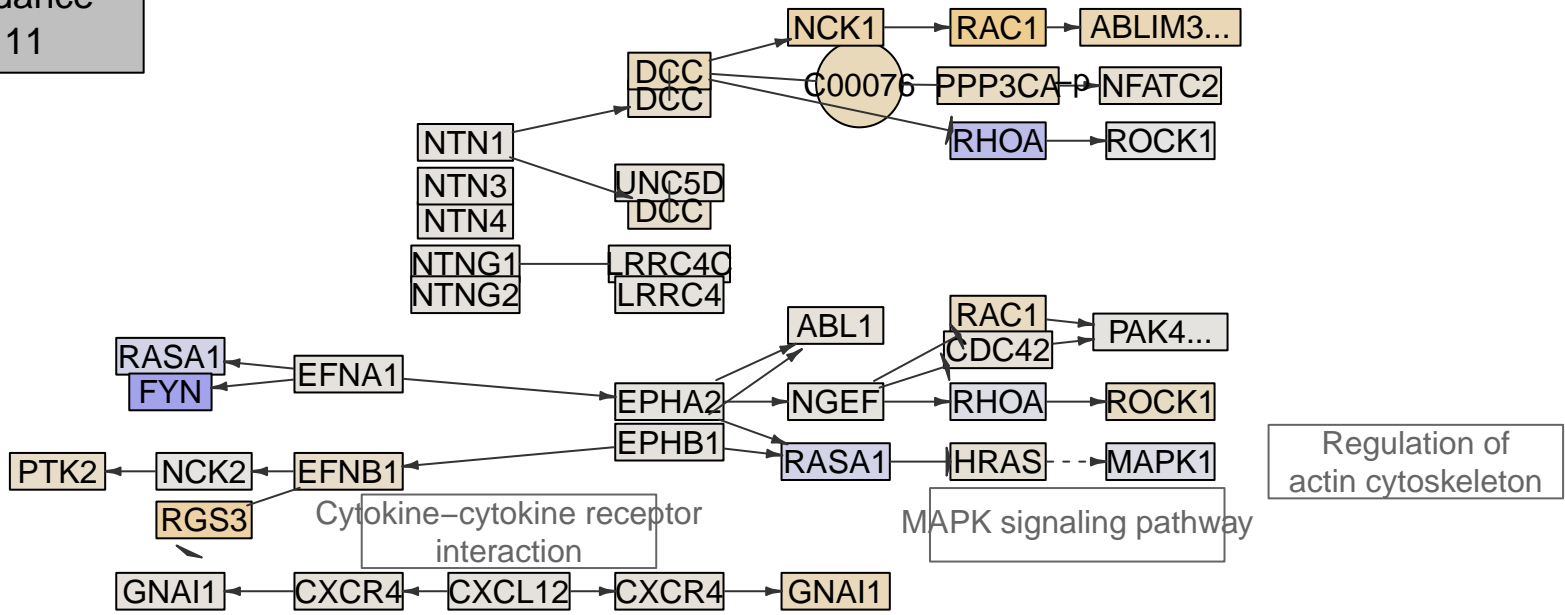

Regulation of actin cytoskeleton

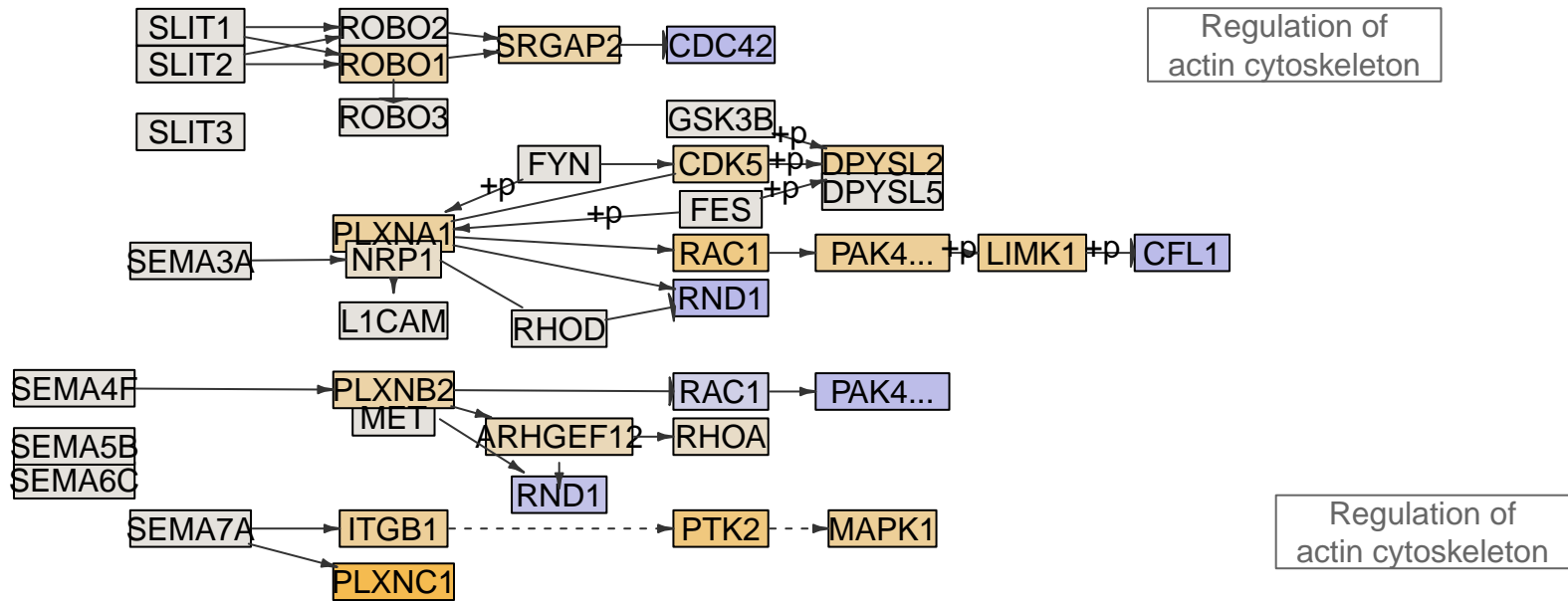

Regulation of actin cytoskeleton

Regulation of actin cytoskeleton

Axon guidance
MPI-113

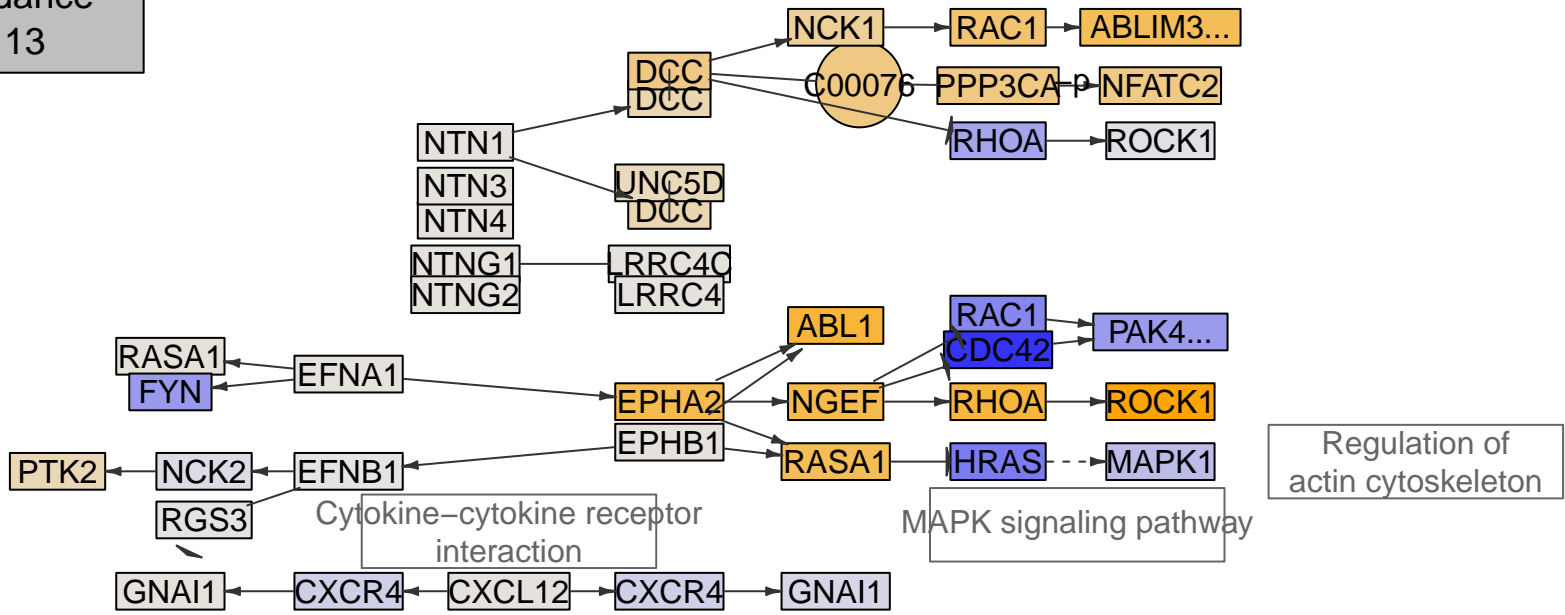

Regulation of actin cytoskeleton

MAPK signaling pathway

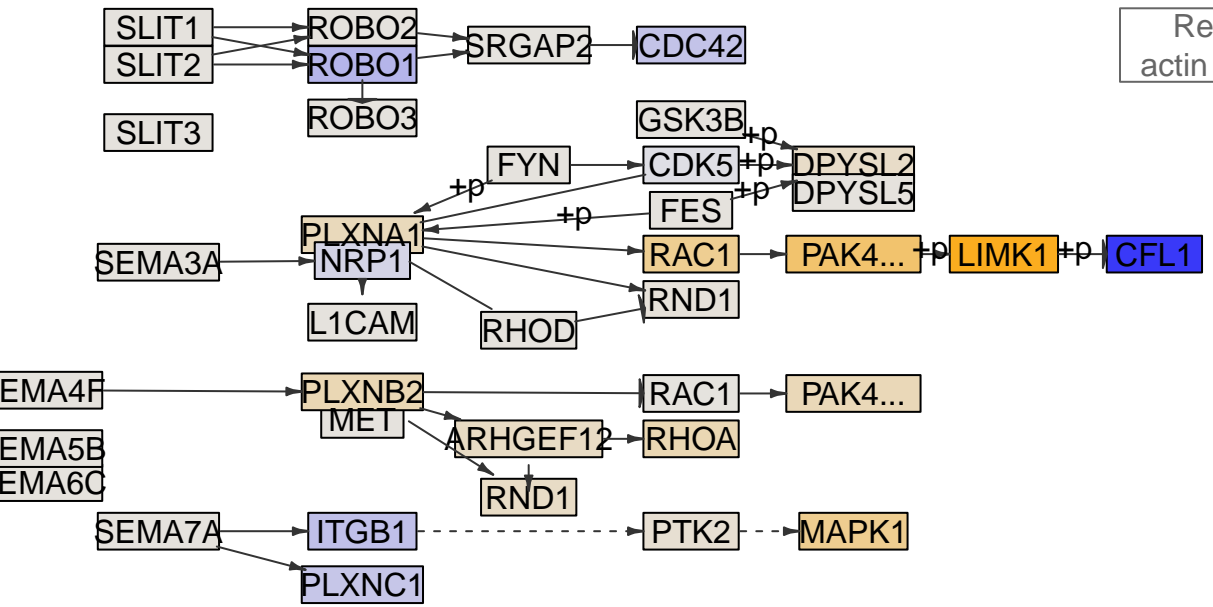

Regulation of actin cytoskeleton

Regulation of actin cytoskeleton

Axon guidance
MPI-115

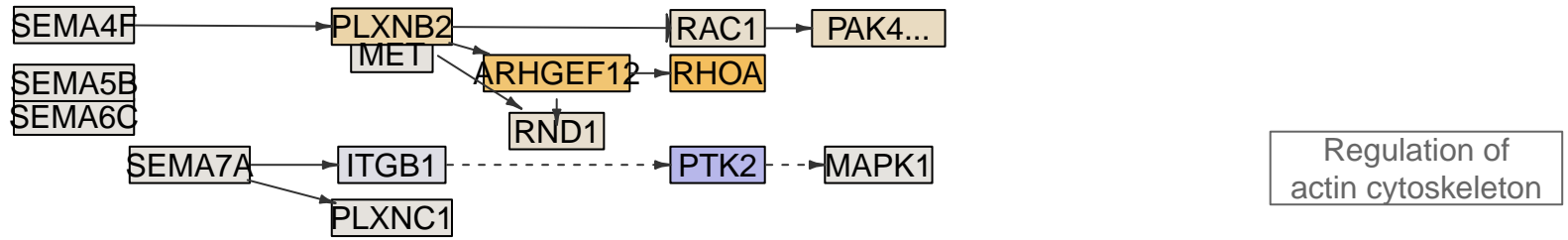
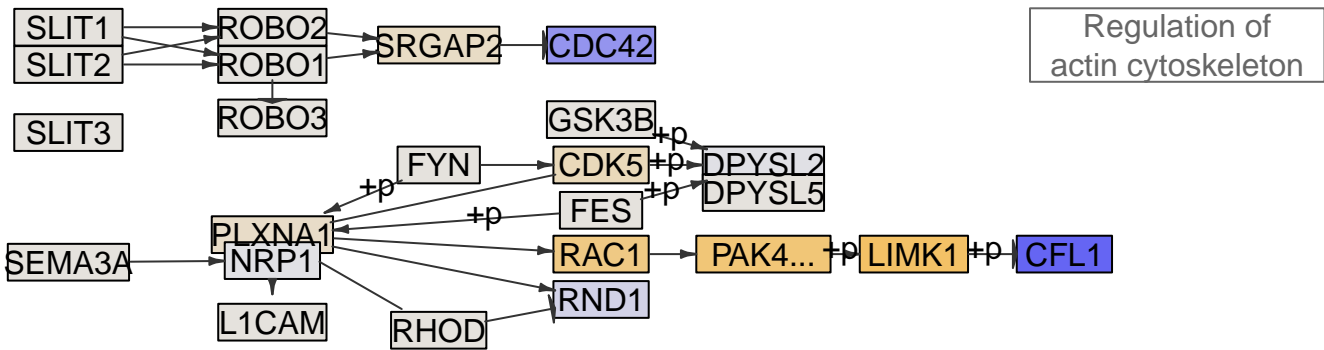
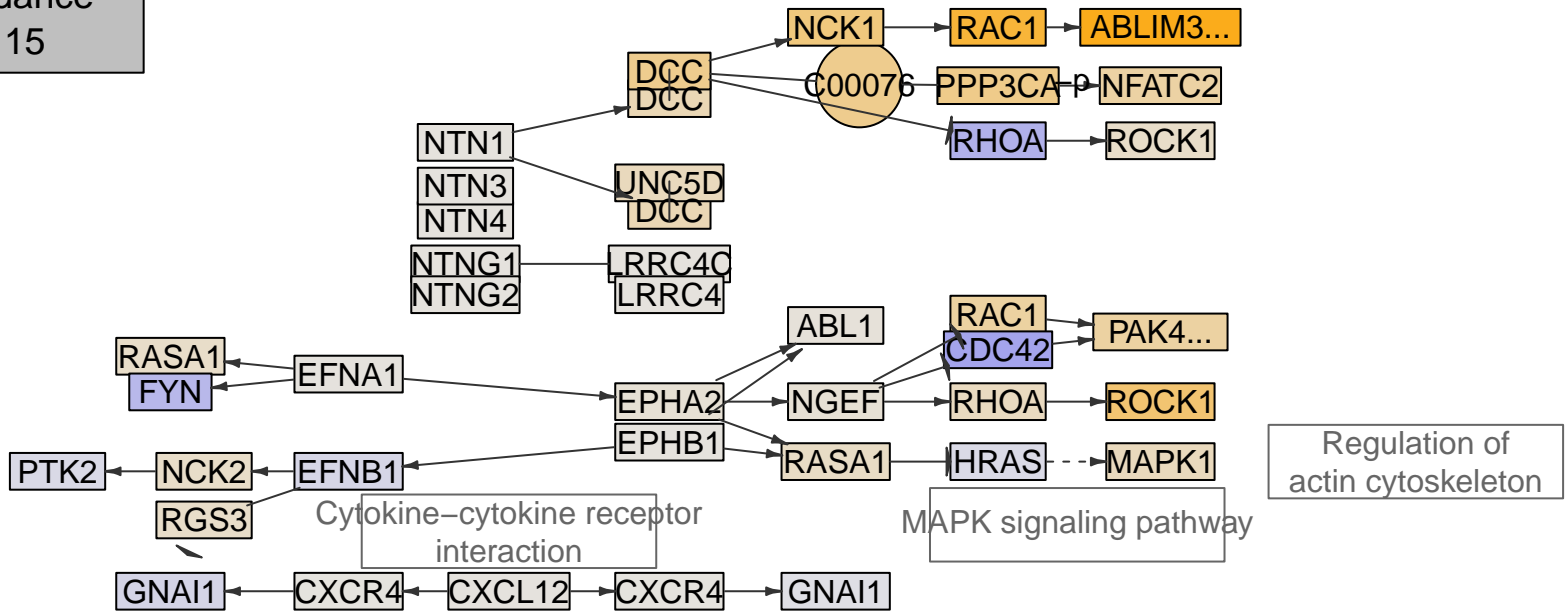

Axon guidance
MPI-118

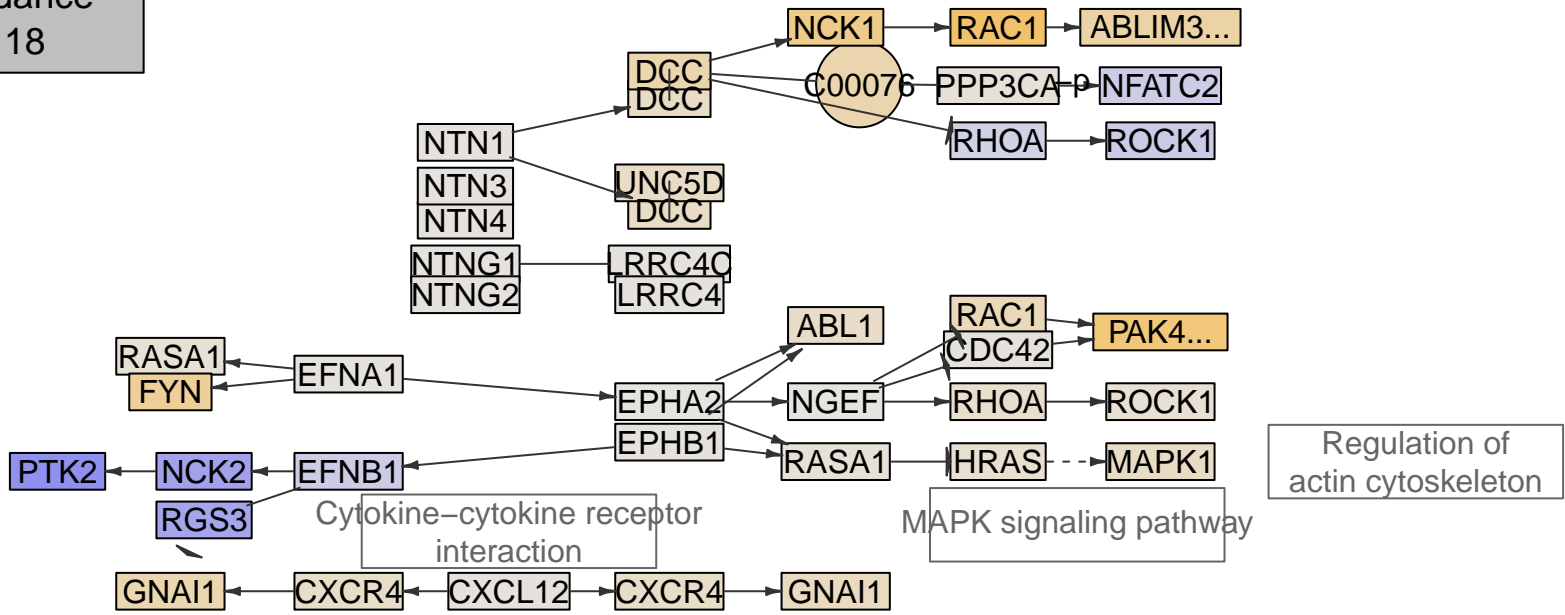

Regulation of actin cytoskeleton

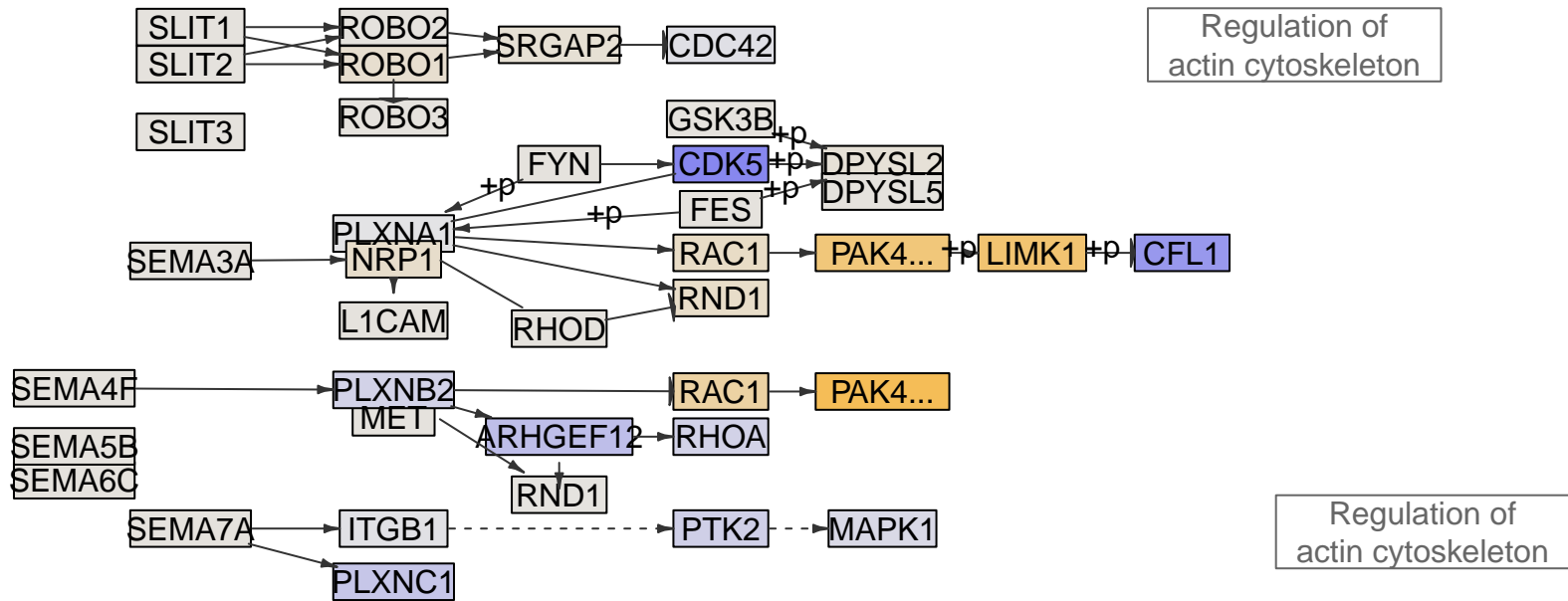

Regulation of actin cytoskeleton

Regulation of actin cytoskeleton

Axon guidance
MPI-119

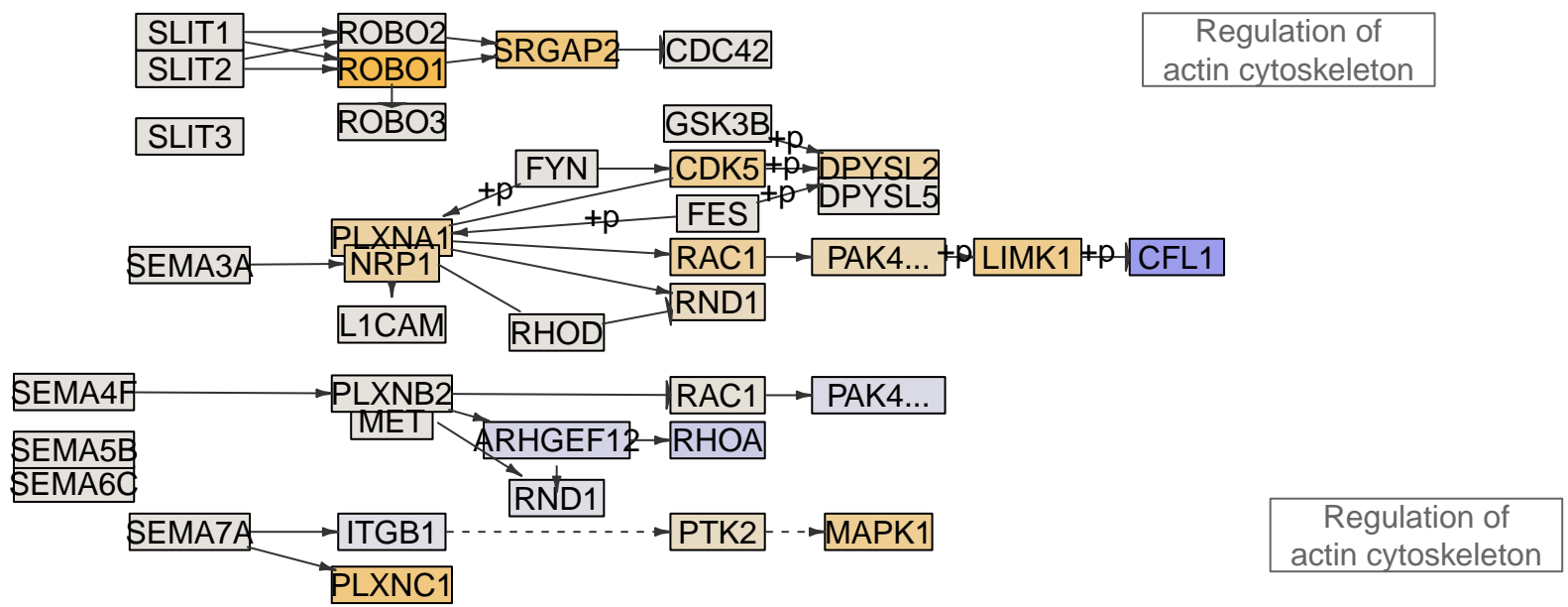
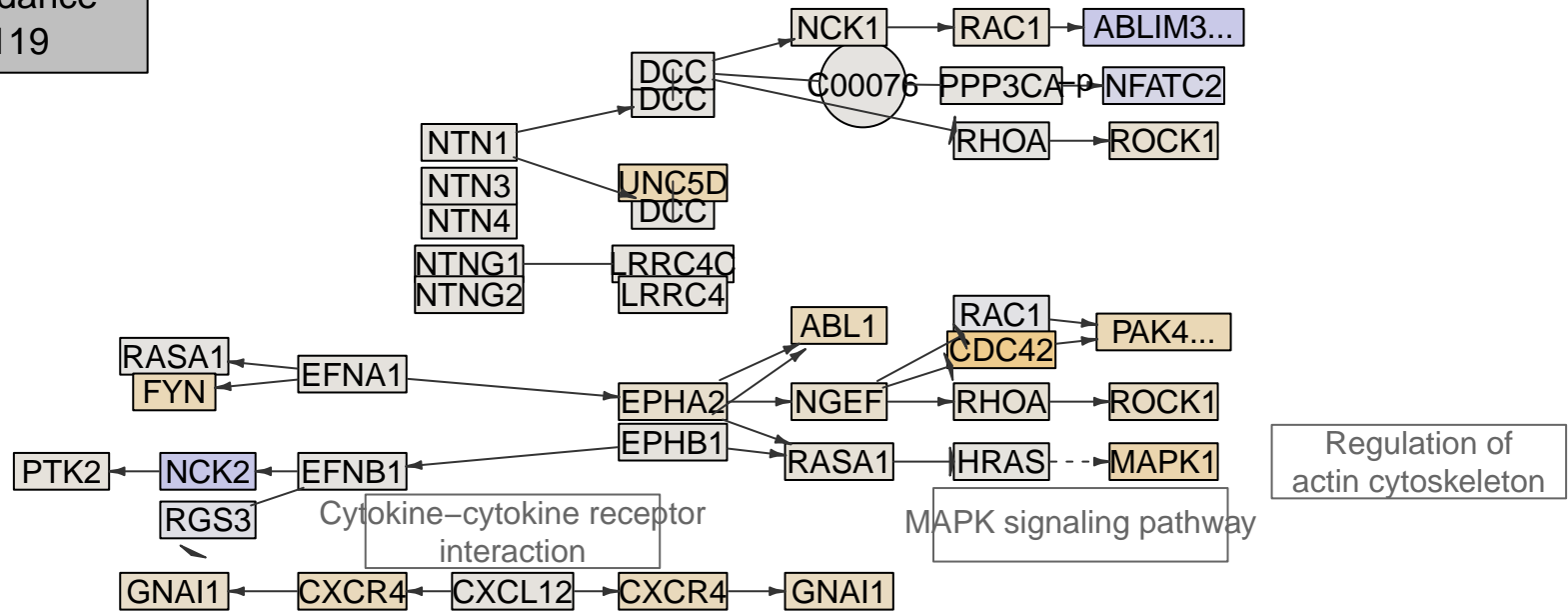

Axon guidance
MPI-122

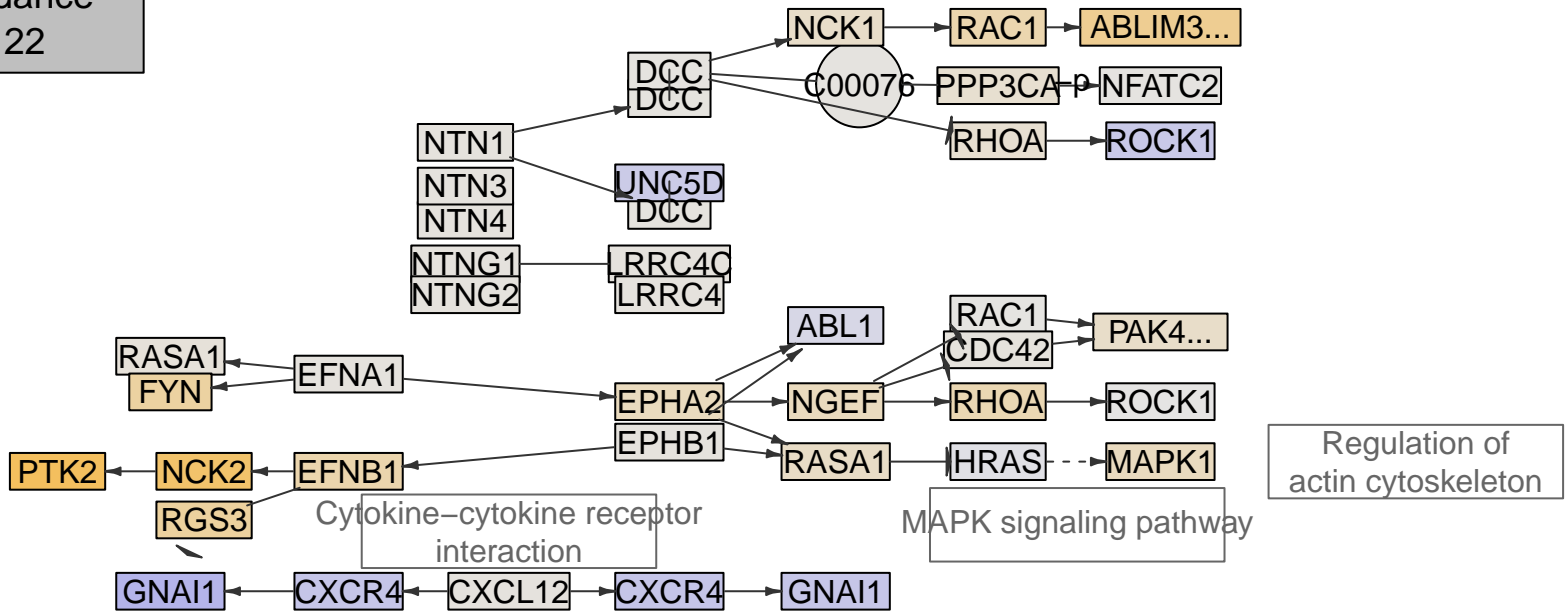

Regulation of actin cytoskeleton

MAPK signaling pathway

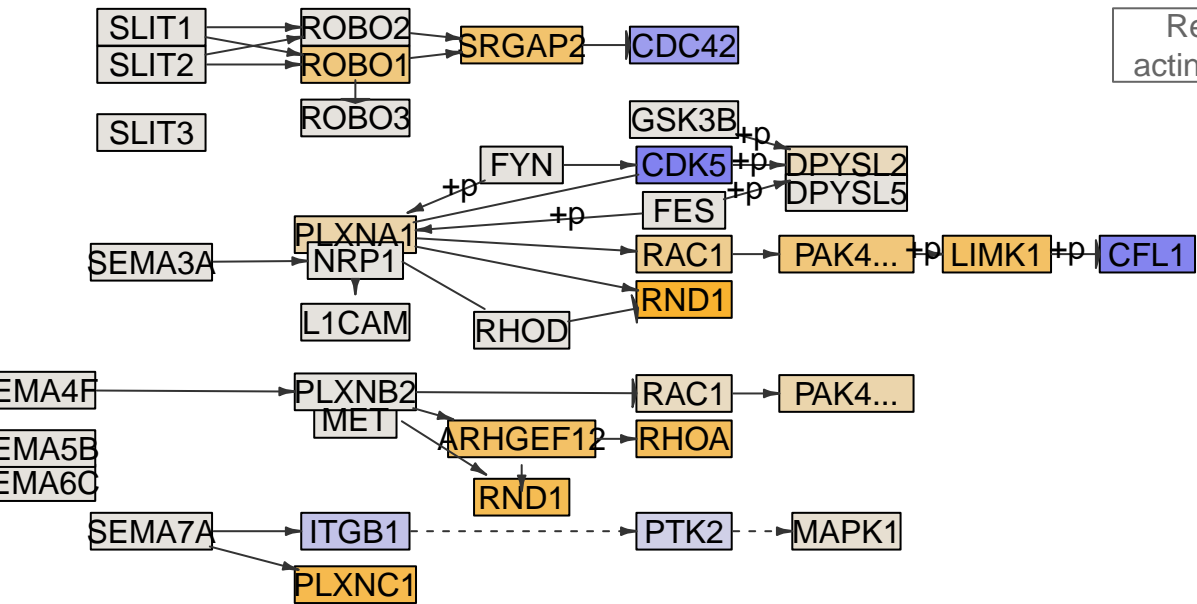

Regulation of actin cytoskeleton

Regulation of actin cytoskeleton

Axon guidance
MPI-127

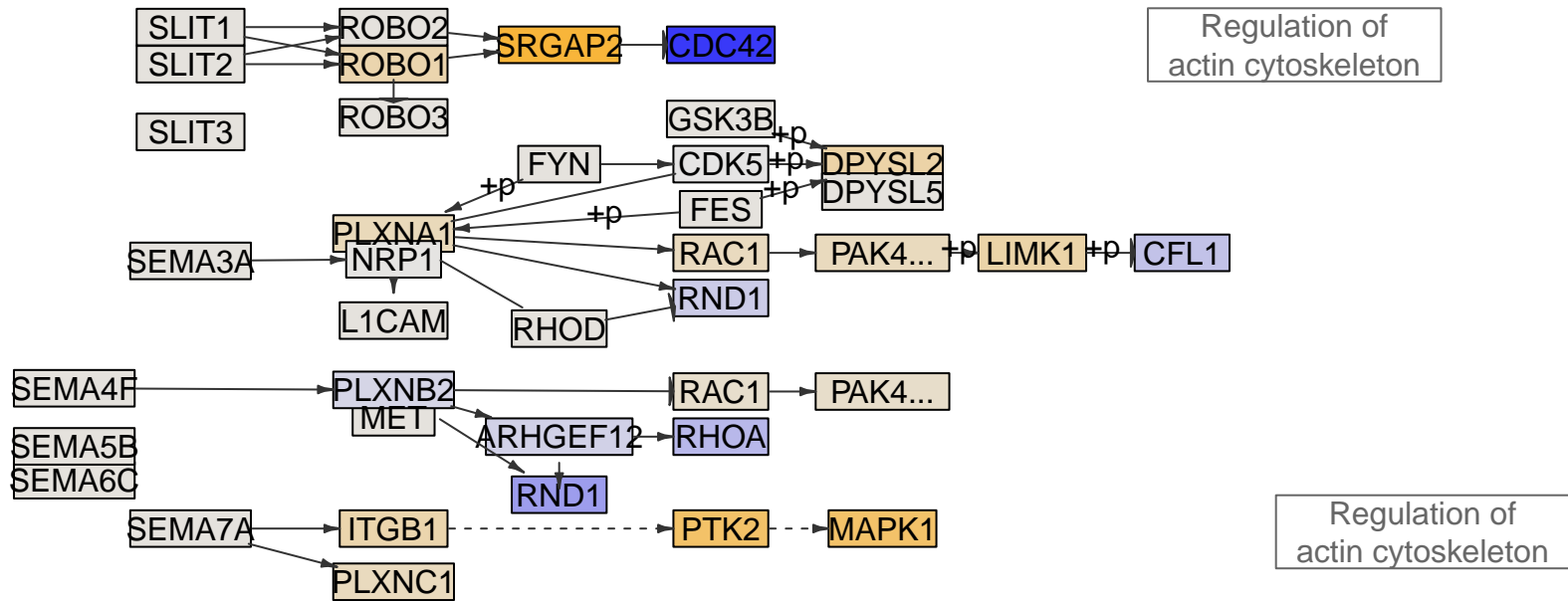
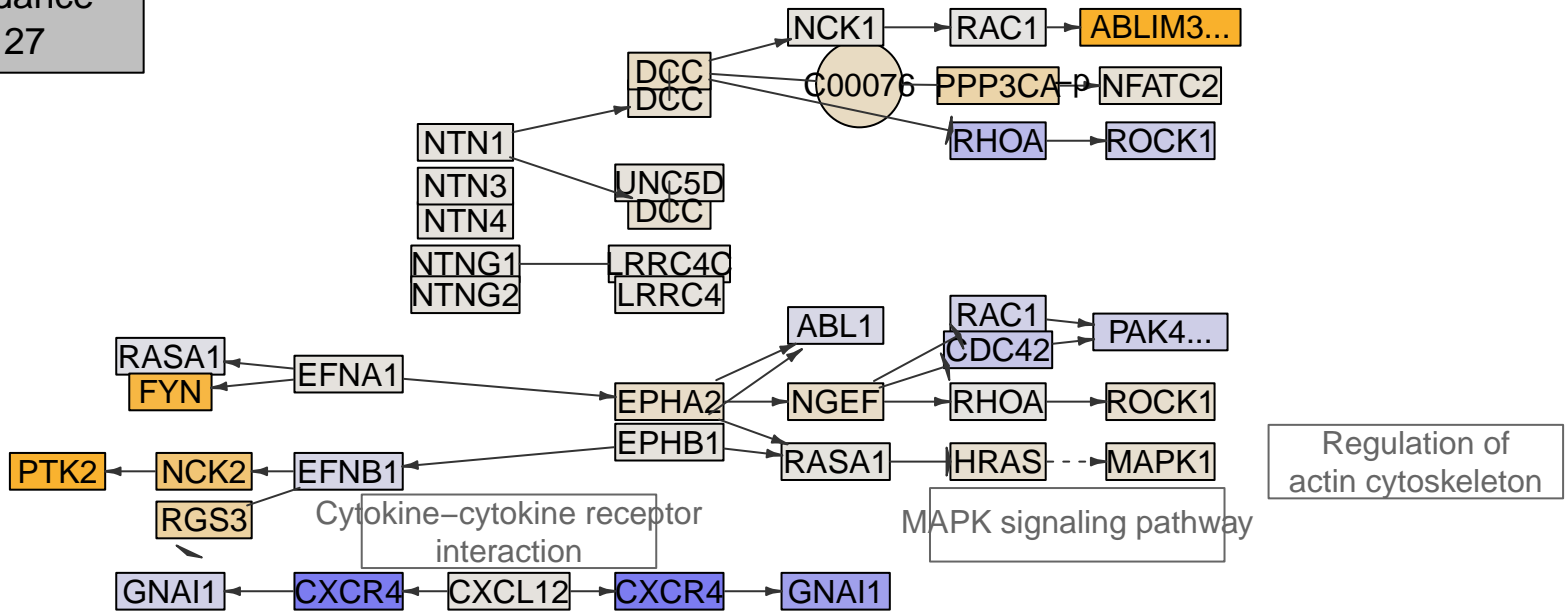

Axon guidance
MPI-128

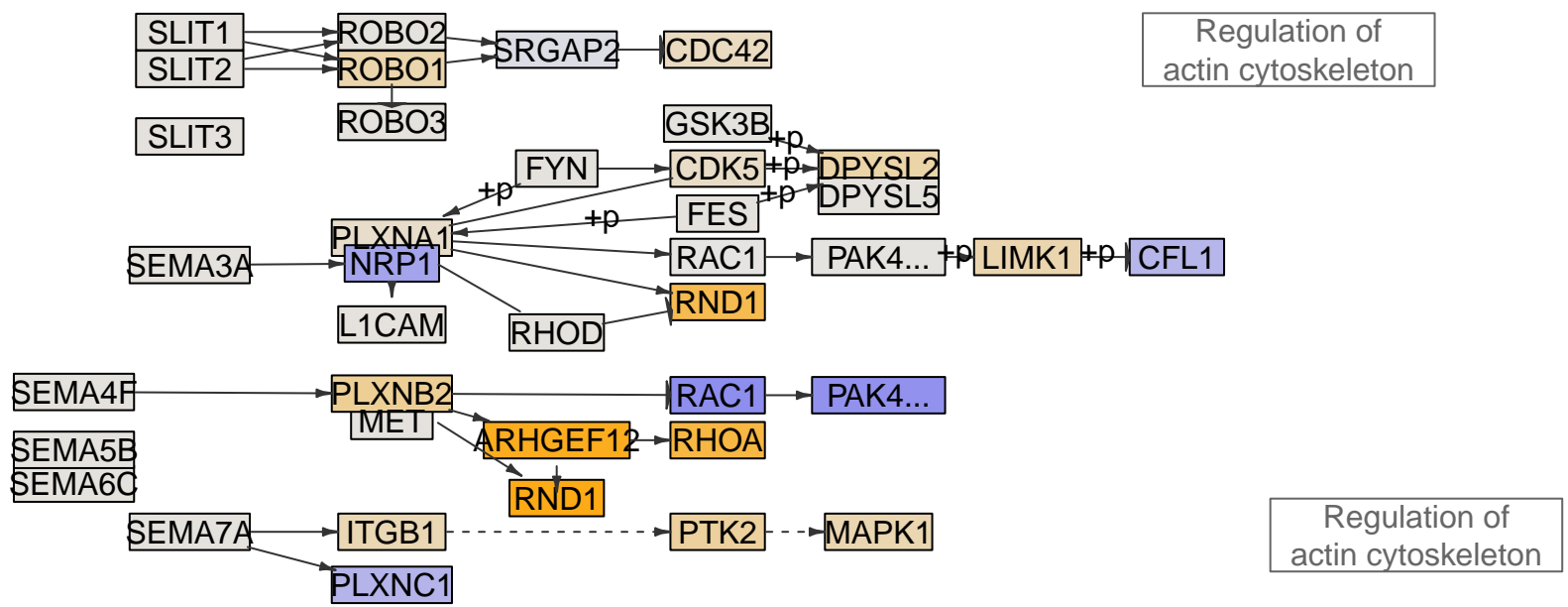
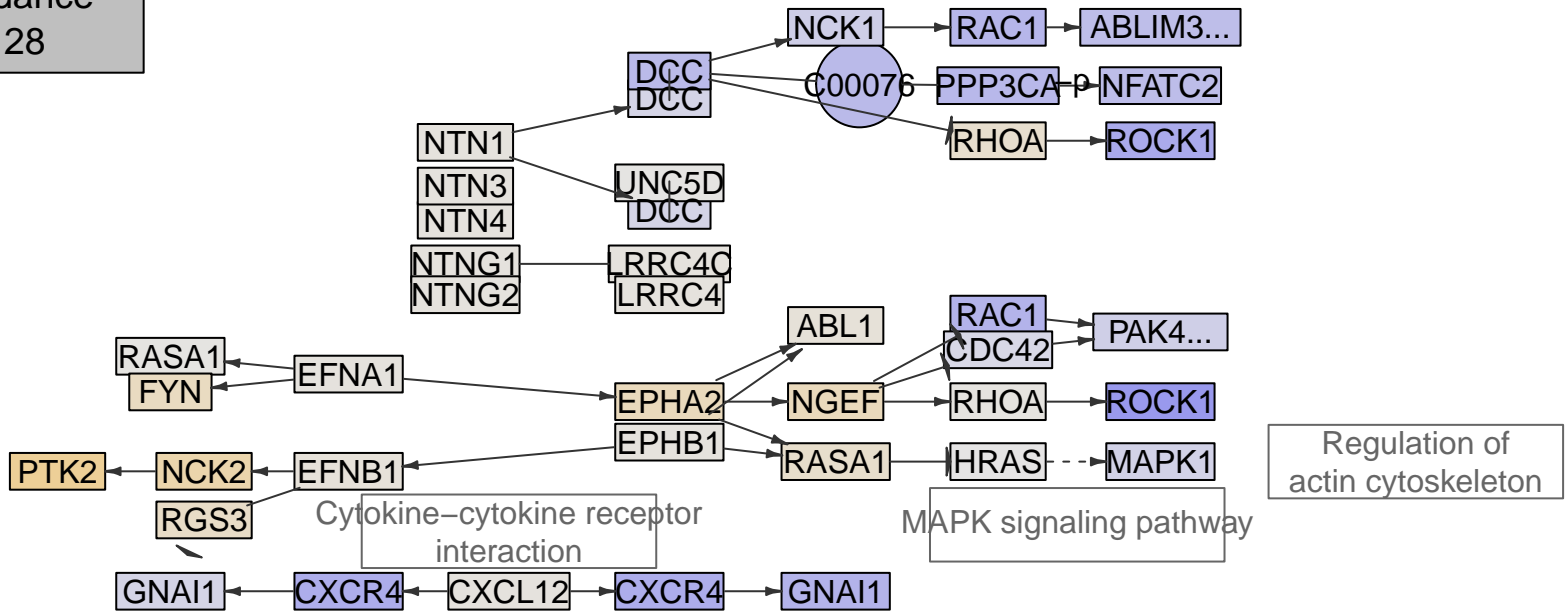

Axon guidance
MPI-129

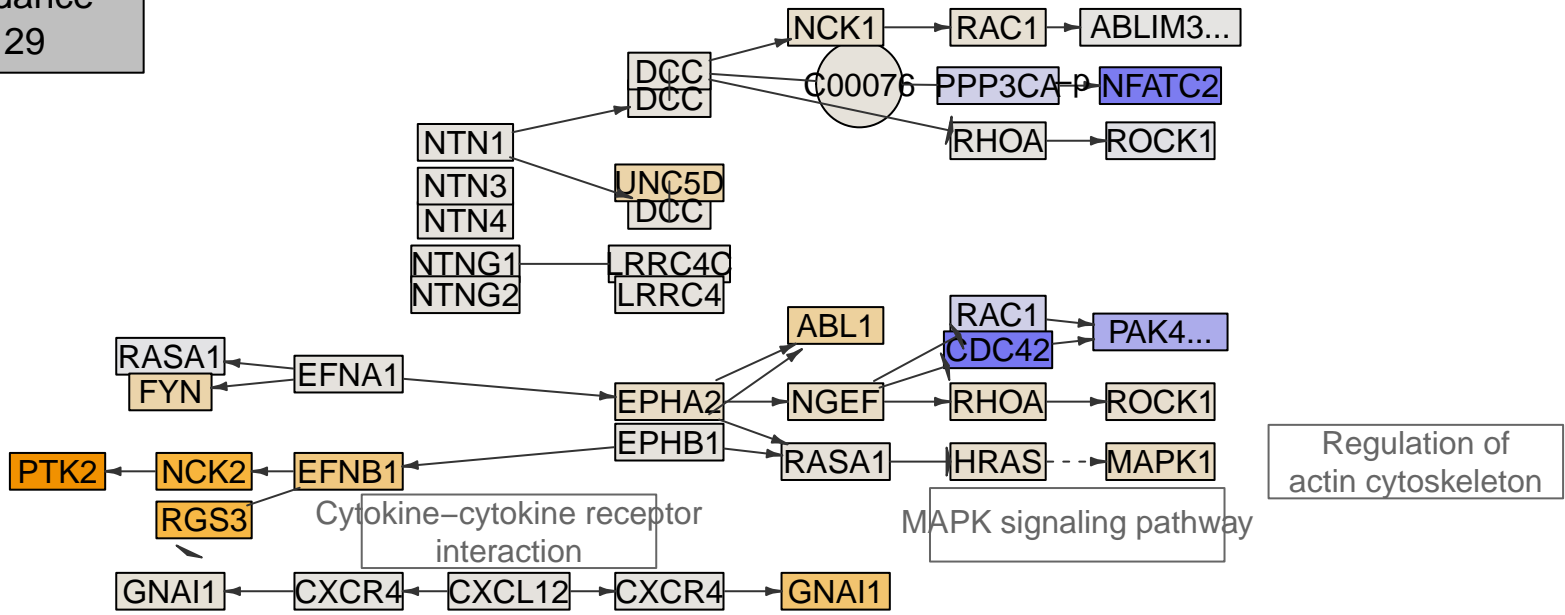

Regulation of actin cytoskeleton

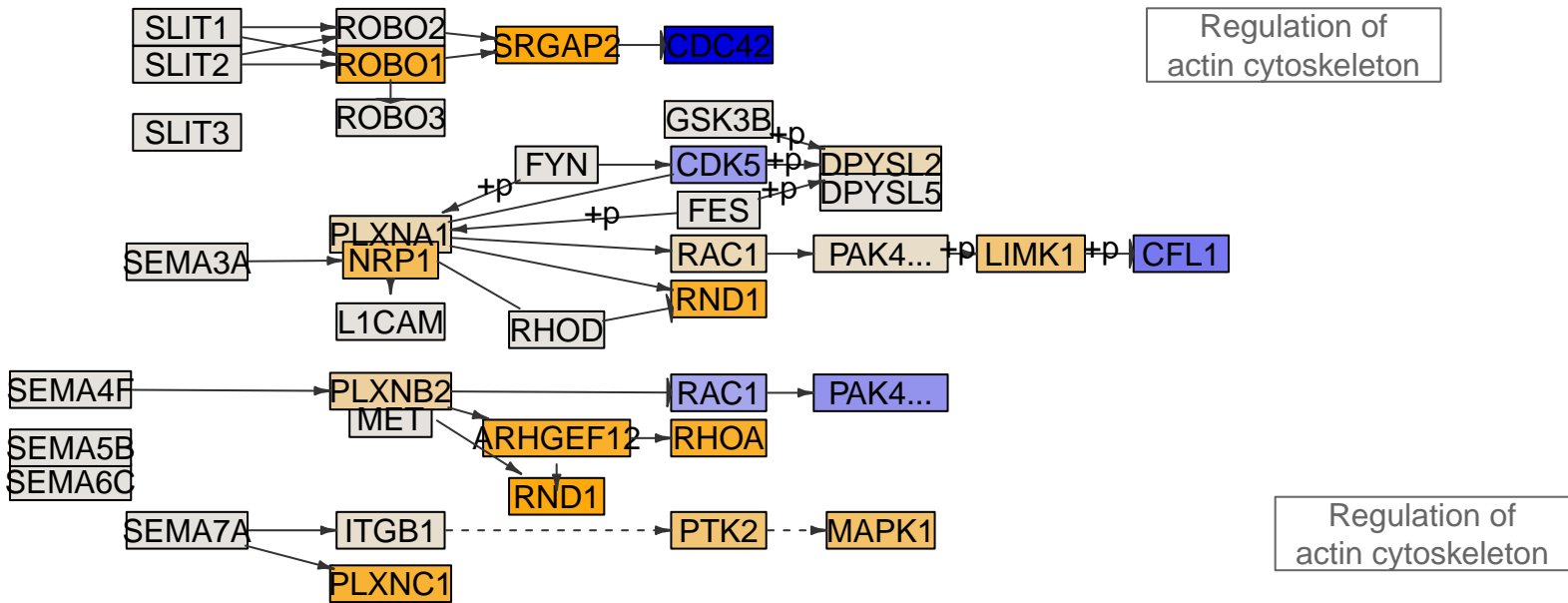

Regulation of actin cytoskeleton

Regulation of actin cytoskeleton

Axon guidance
MPI-130

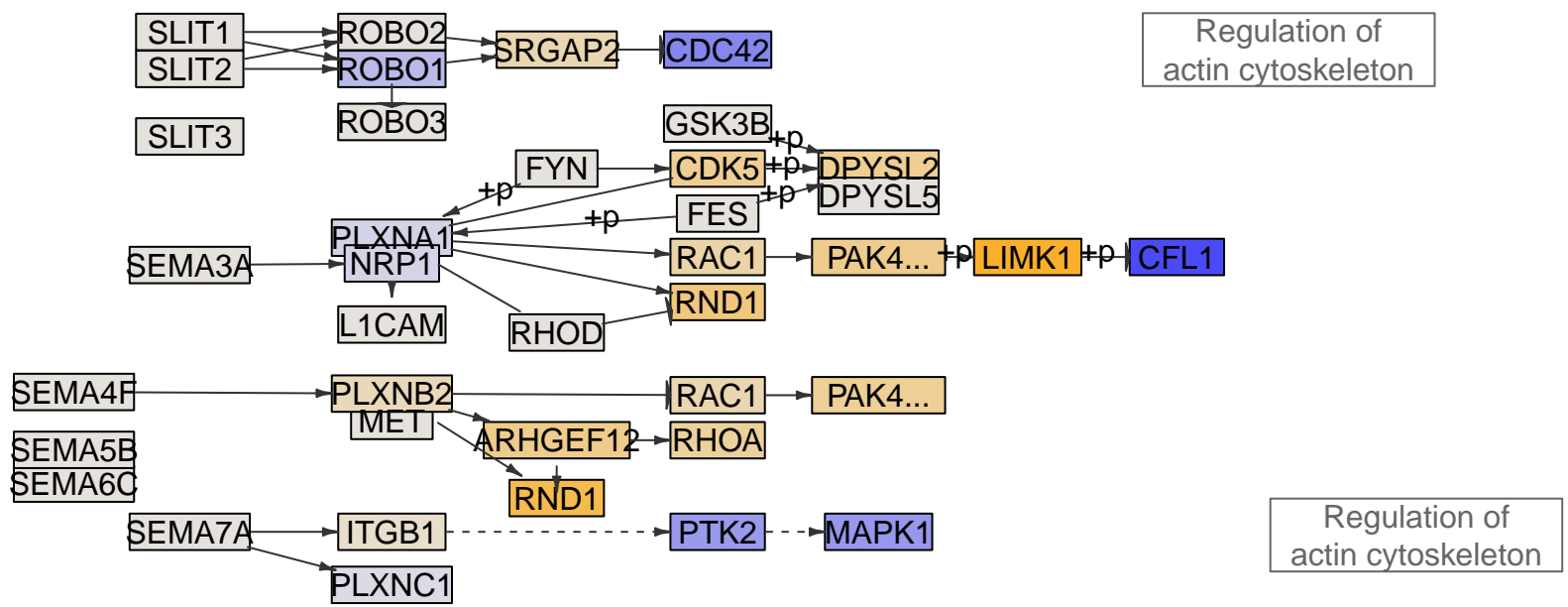
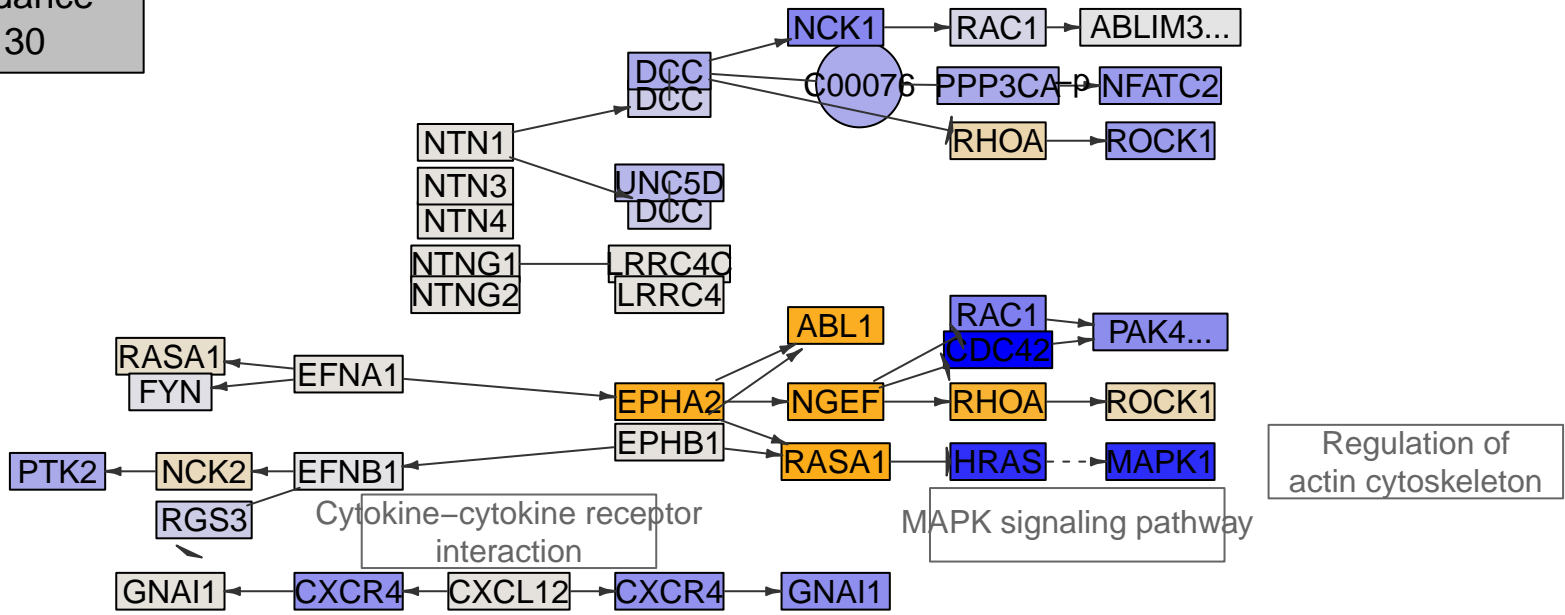

Axon guidance
MPI-132

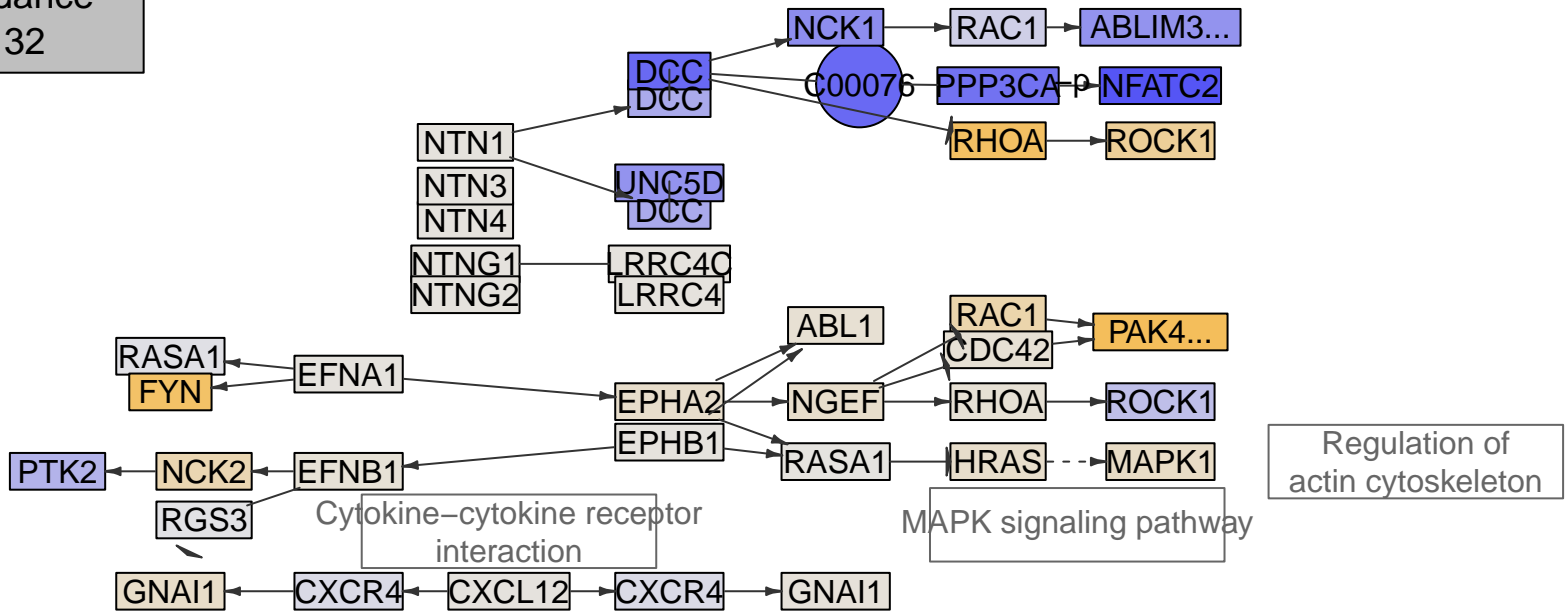

Regulation of actin cytoskeleton

MAPK signaling pathway

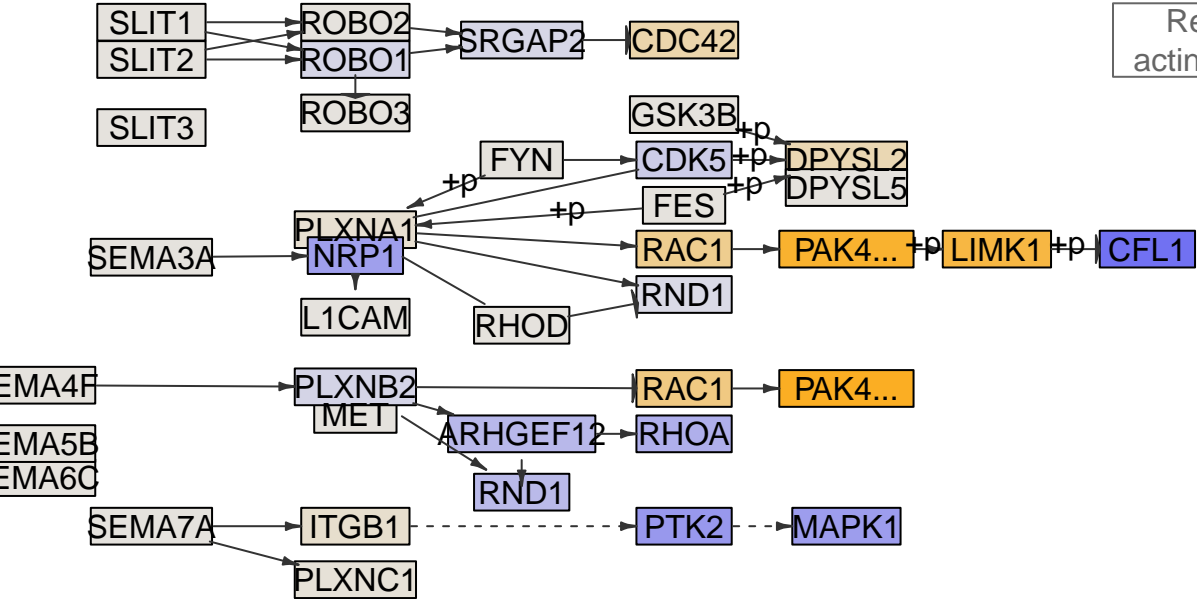

Regulation of actin cytoskeleton

Regulation of actin cytoskeleton

Axon guidance
MPI-133

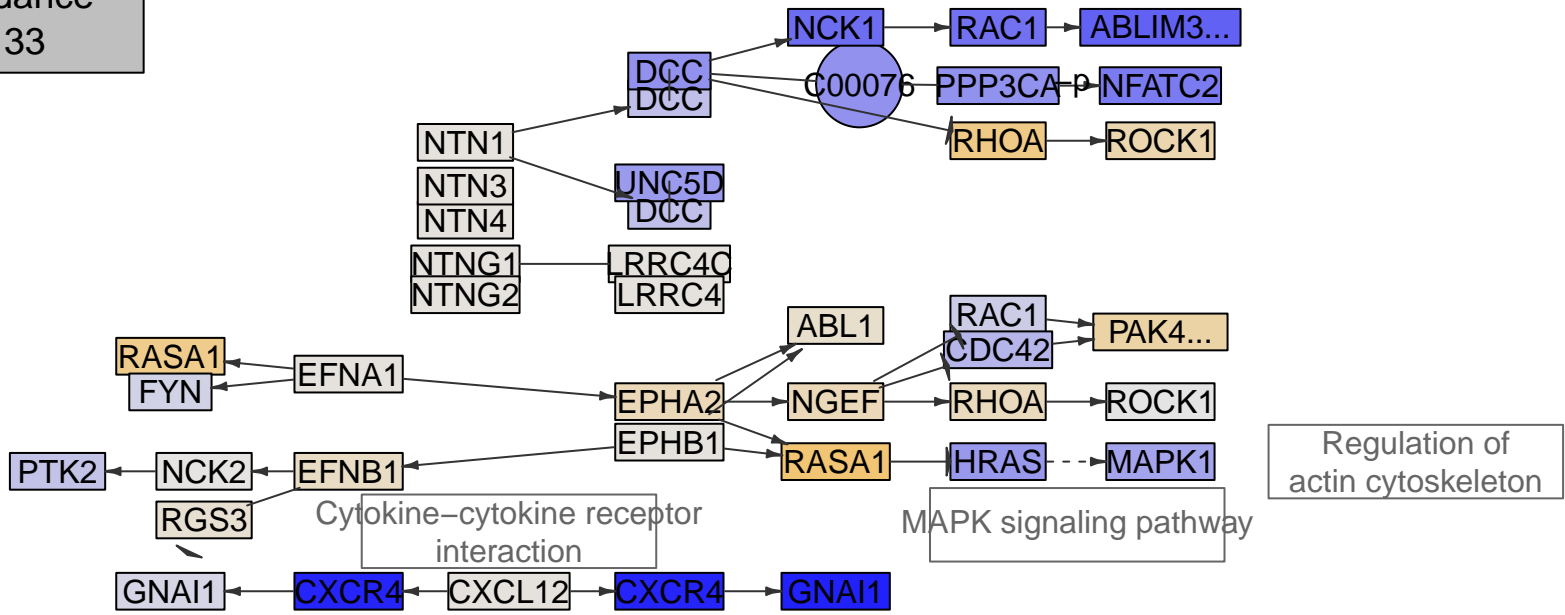

Regulation of actin cytoskeleton

MAPK signaling pathway

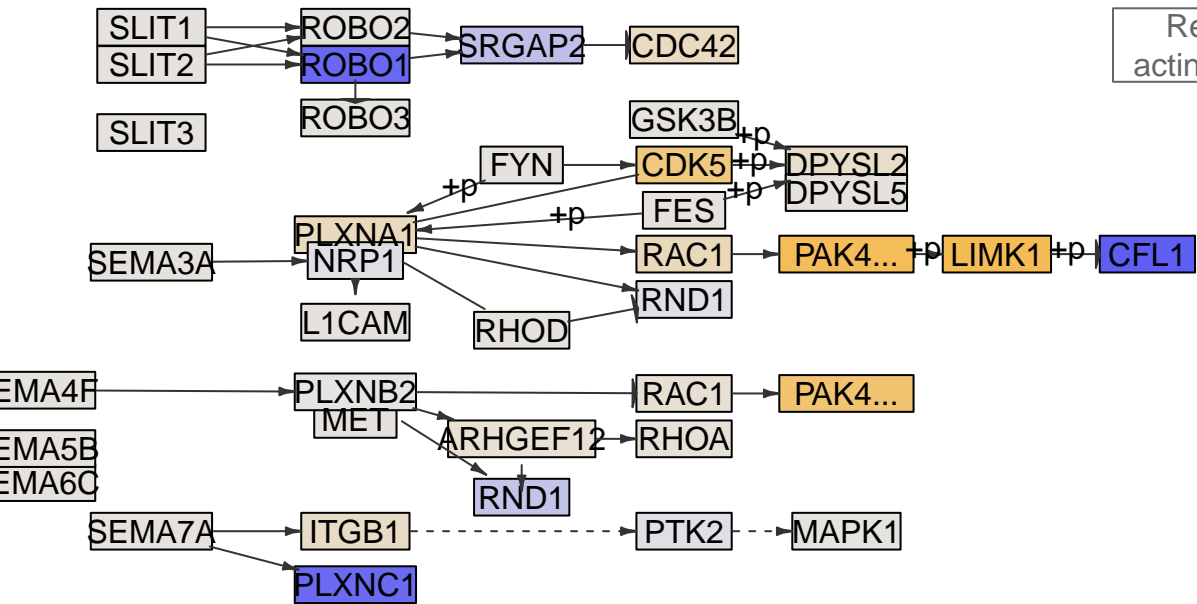

Regulation of actin cytoskeleton

Regulation of actin cytoskeleton

Axon guidance
MPI-134

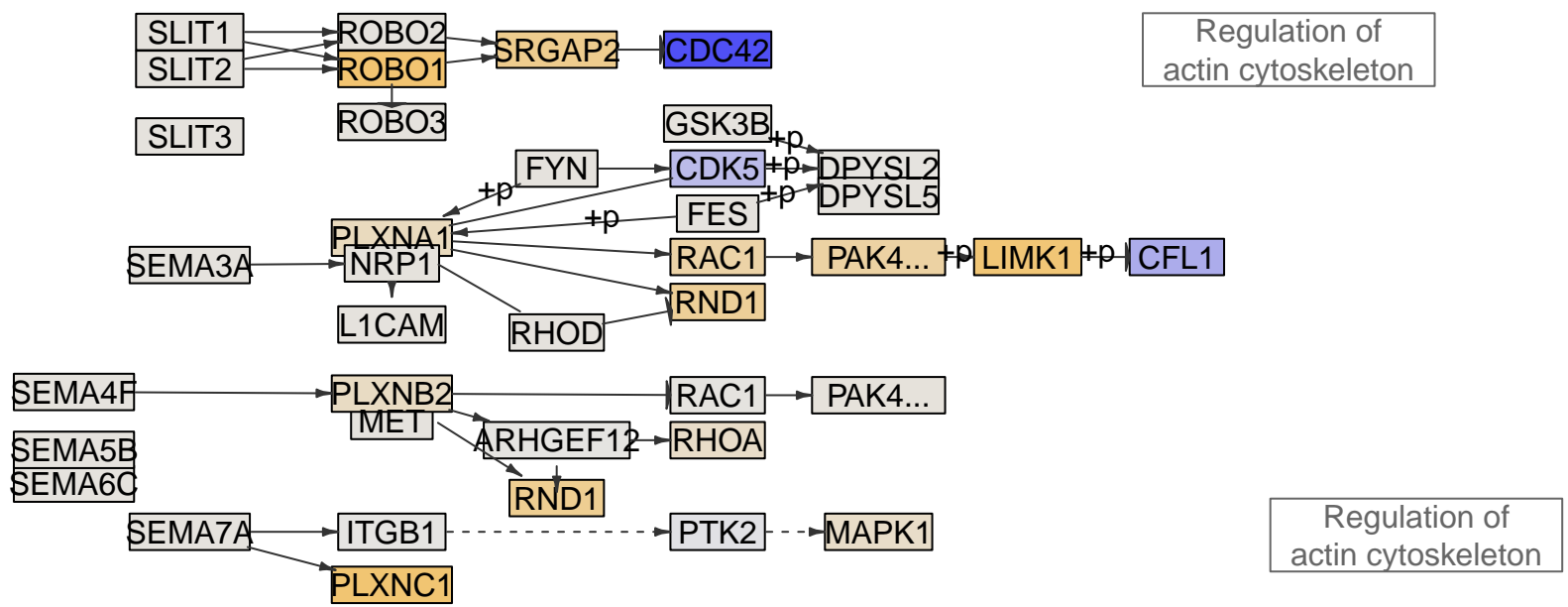
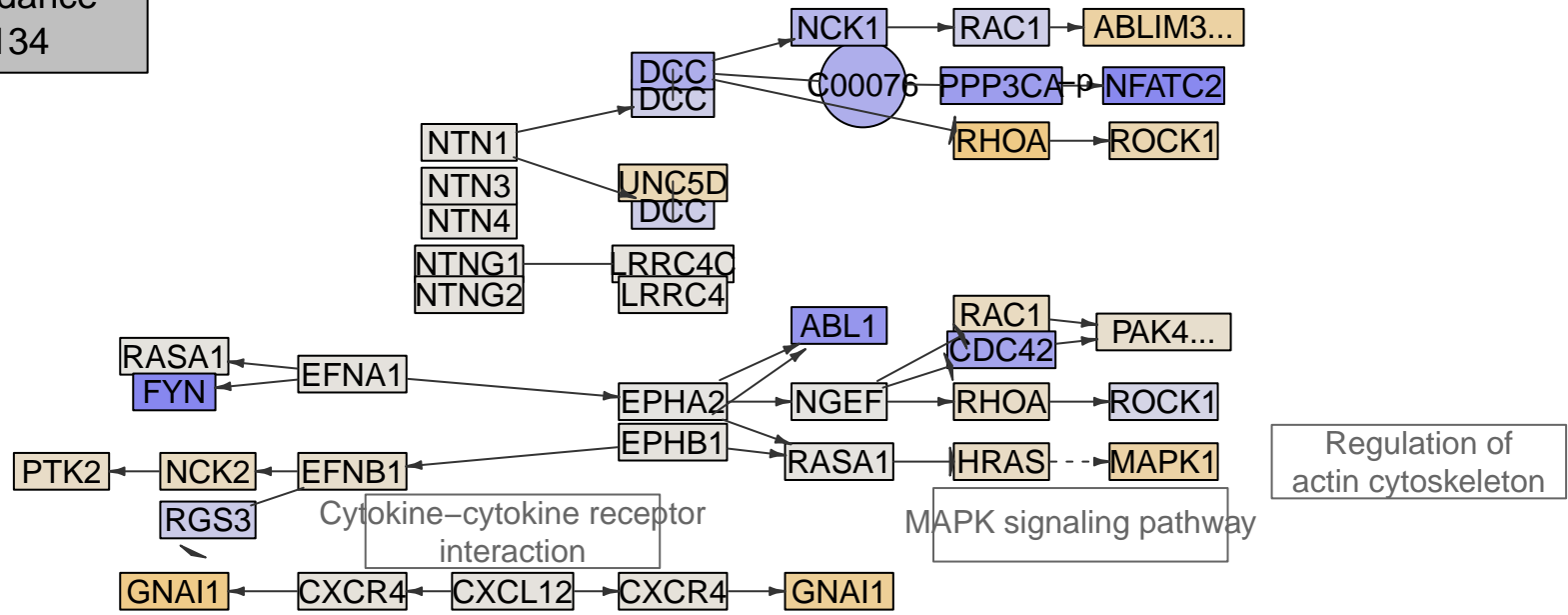

Axon guidance
MPI-135

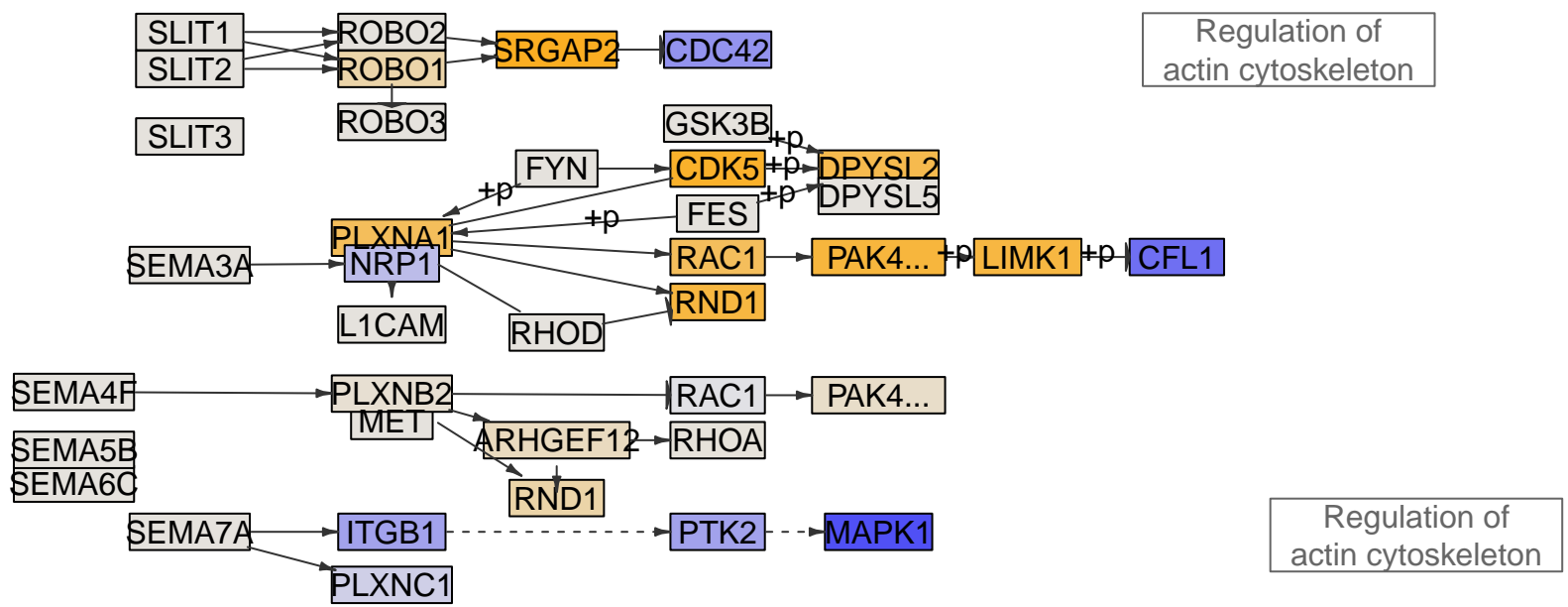
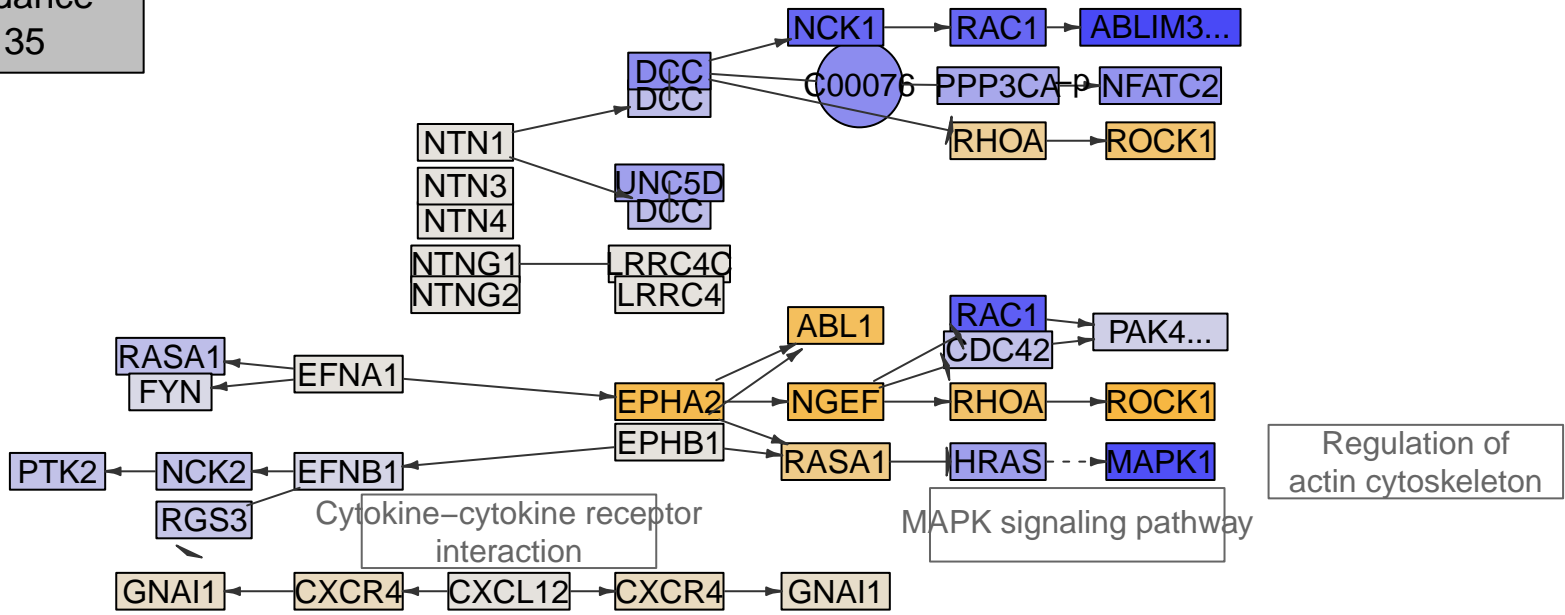

Axon guidance
MPI-136

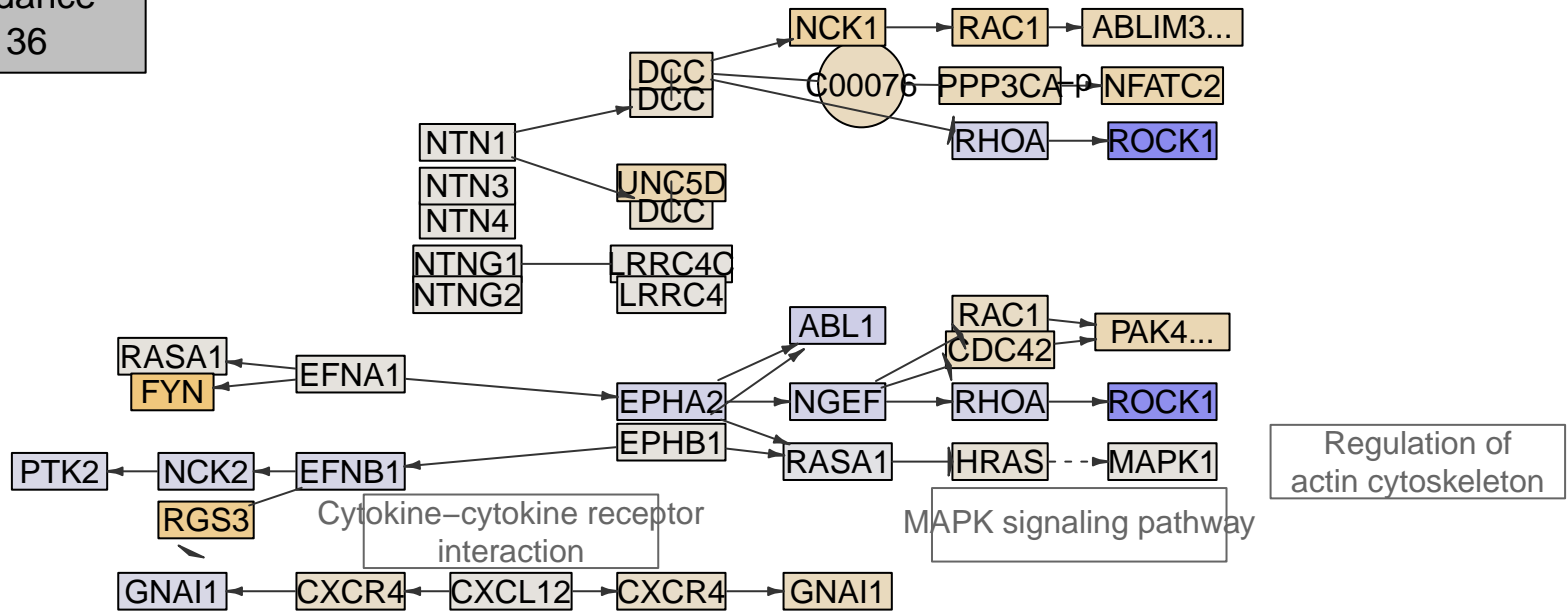

Regulation of actin cytoskeleton

MAPK signaling pathway

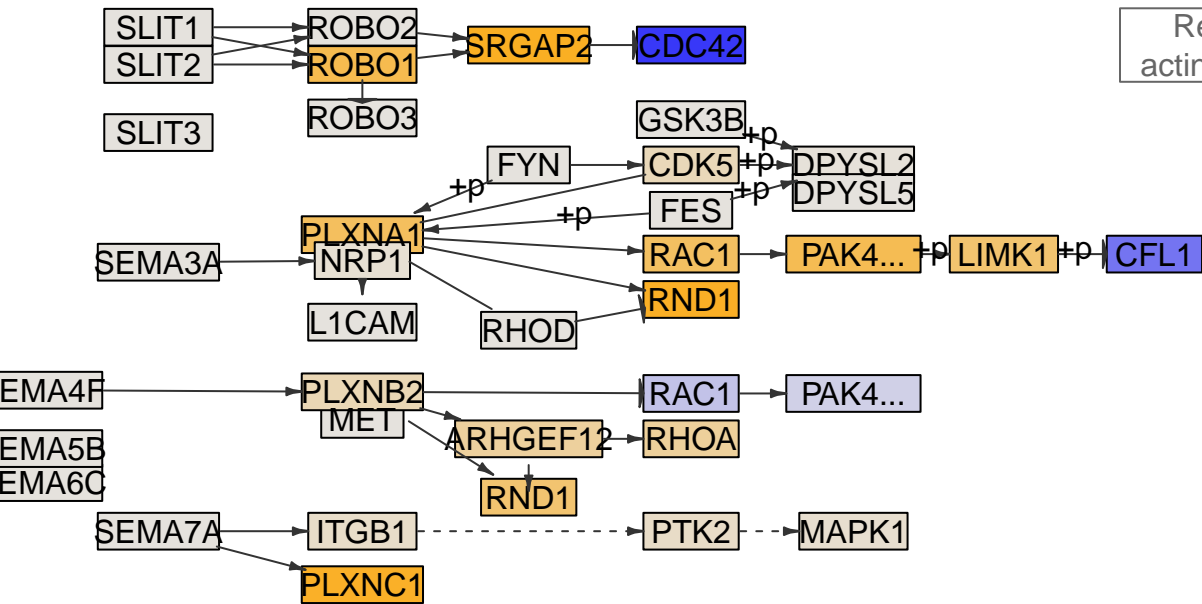

Regulation of actin cytoskeleton

Regulation of actin cytoskeleton

Axon guidance
MPI-141

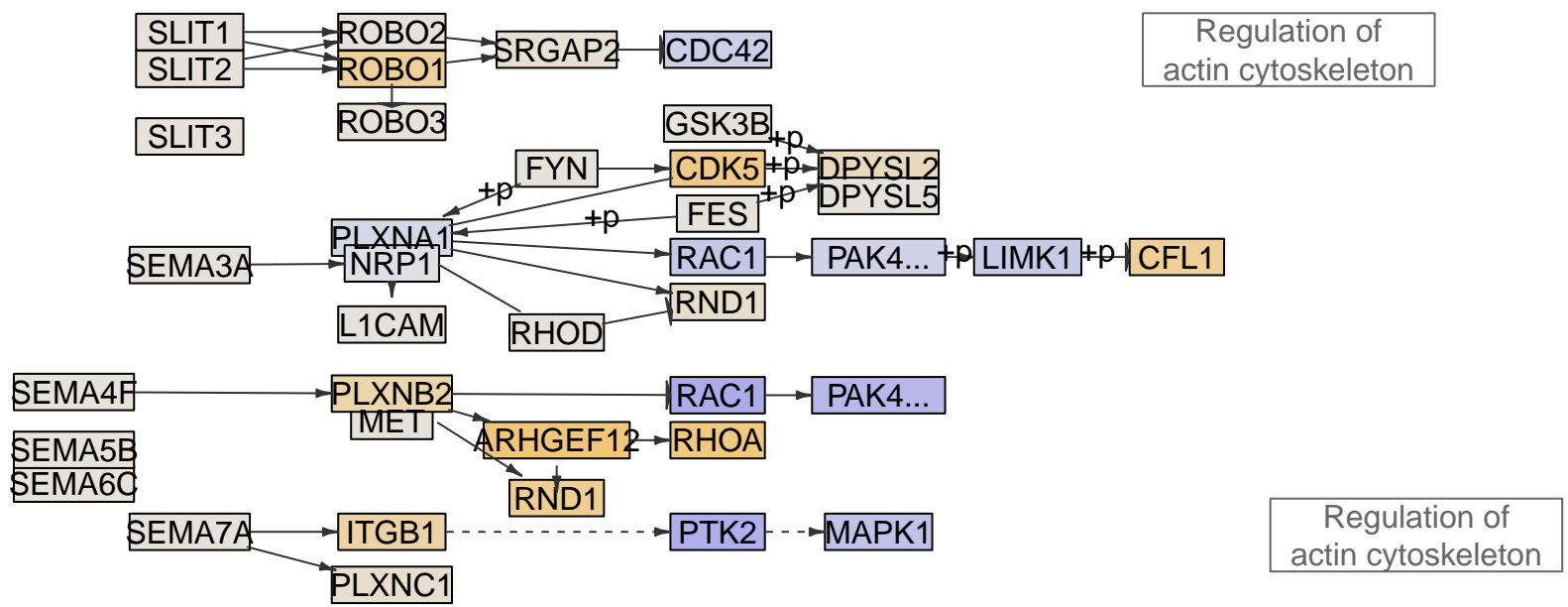
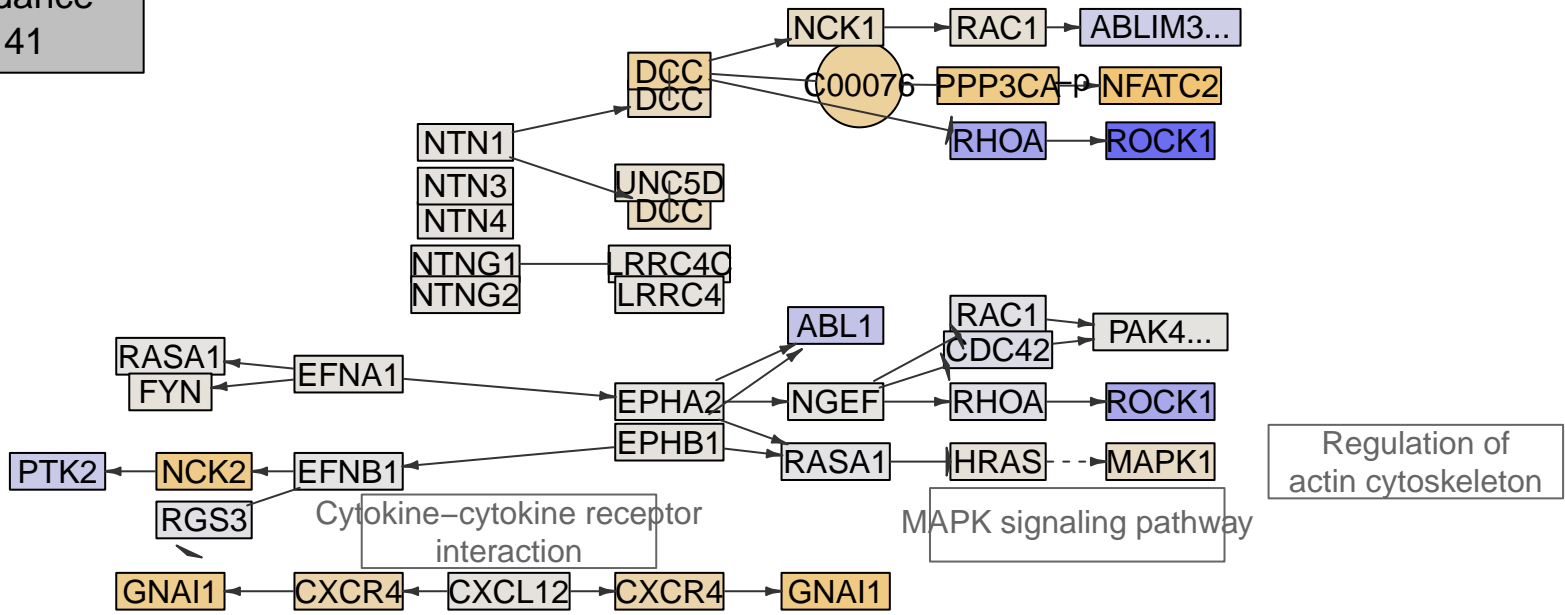

Axon guidance
MPI-142

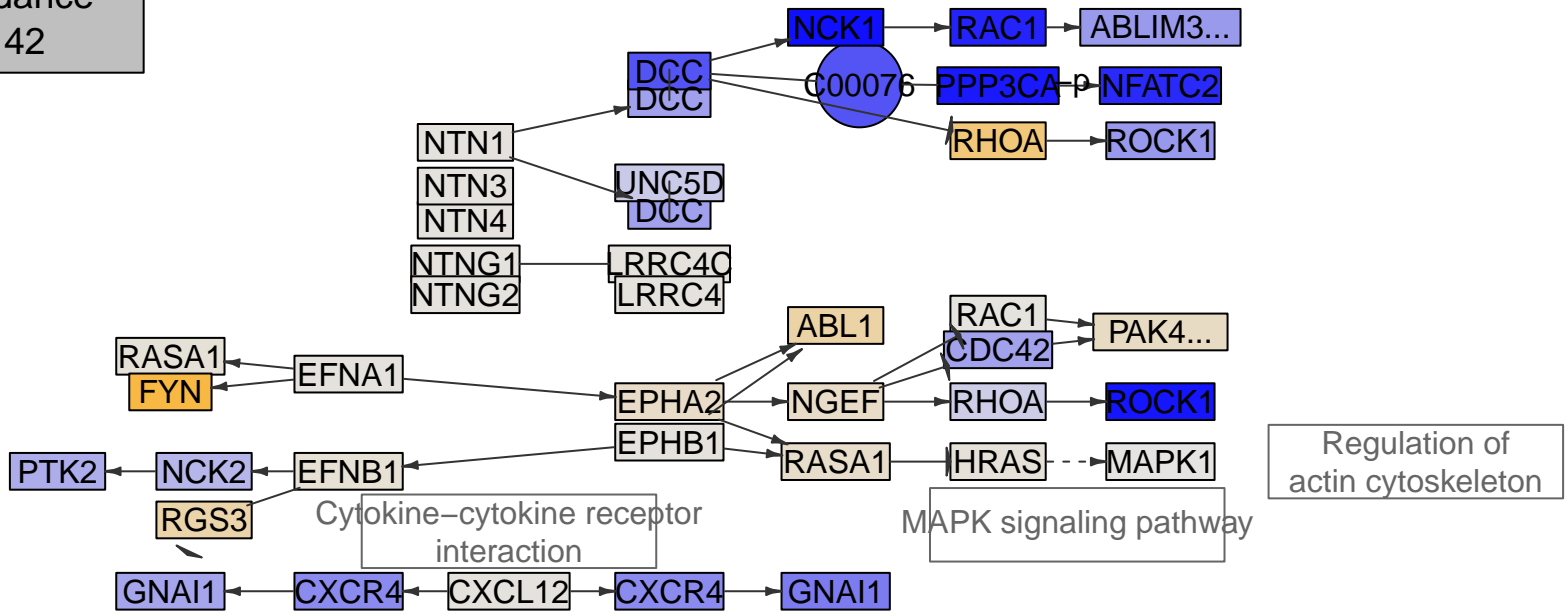

Regulation of actin cytoskeleton

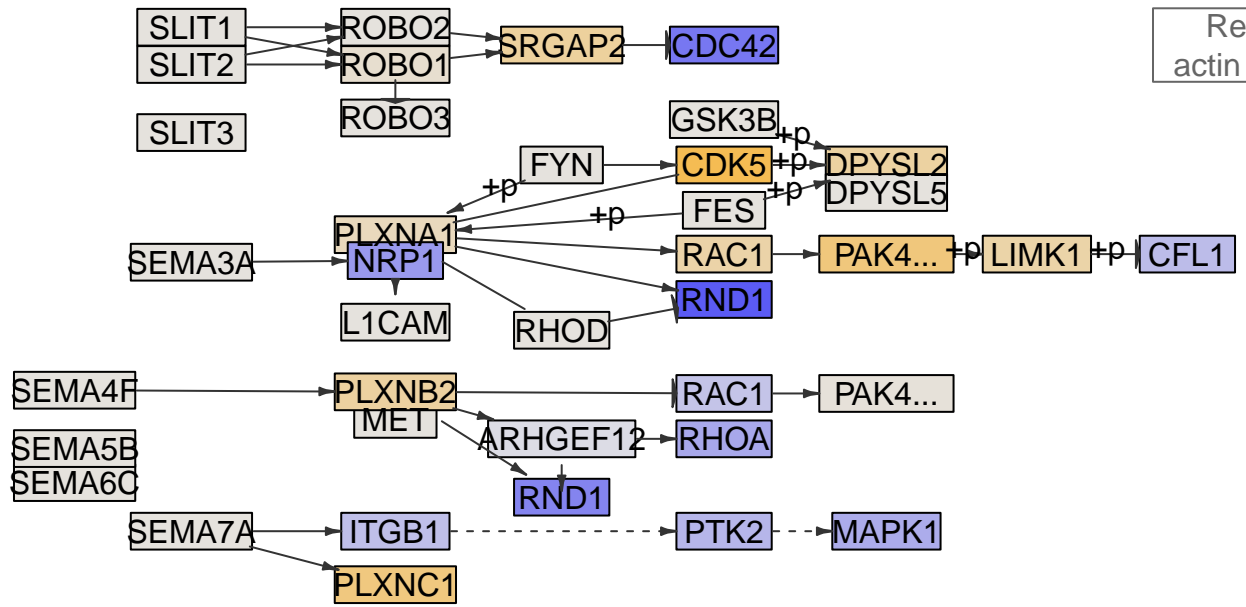

Regulation of actin cytoskeleton

Regulation of actin cytoskeleton

Axon guidance
MPI-145

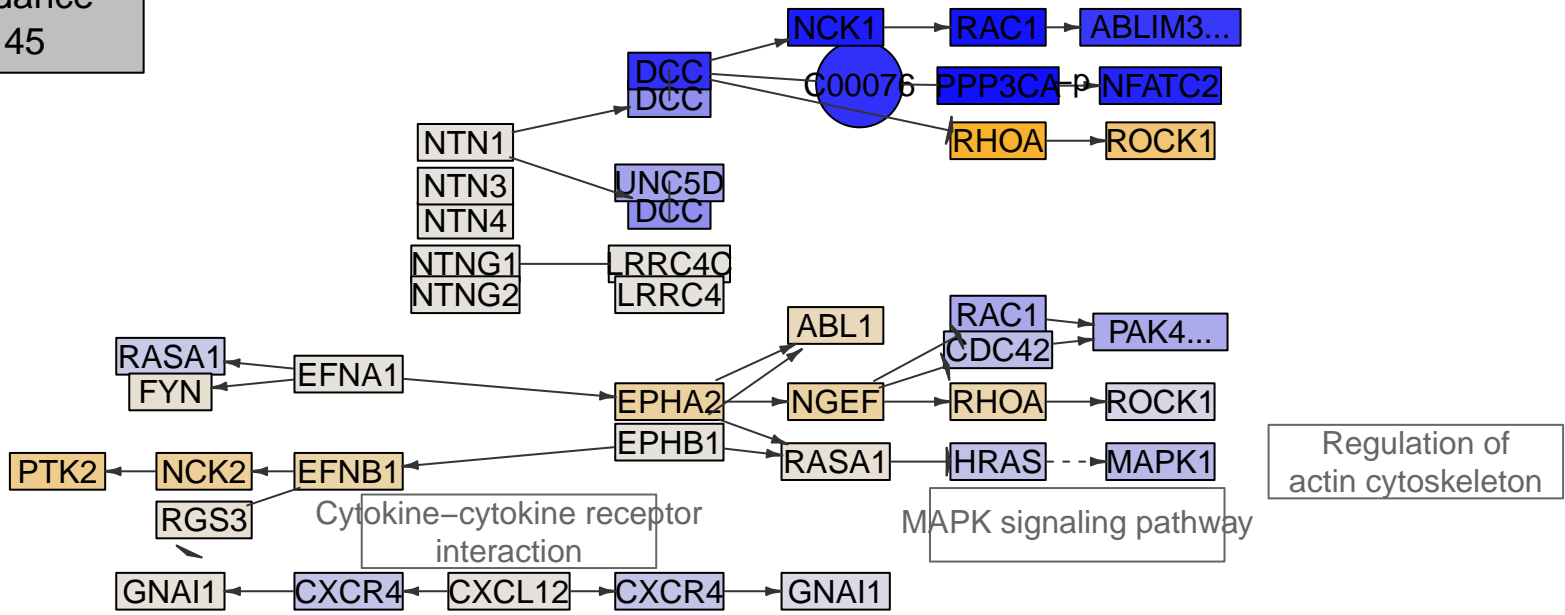

Regulation of actin cytoskeleton

MAPK signaling pathway

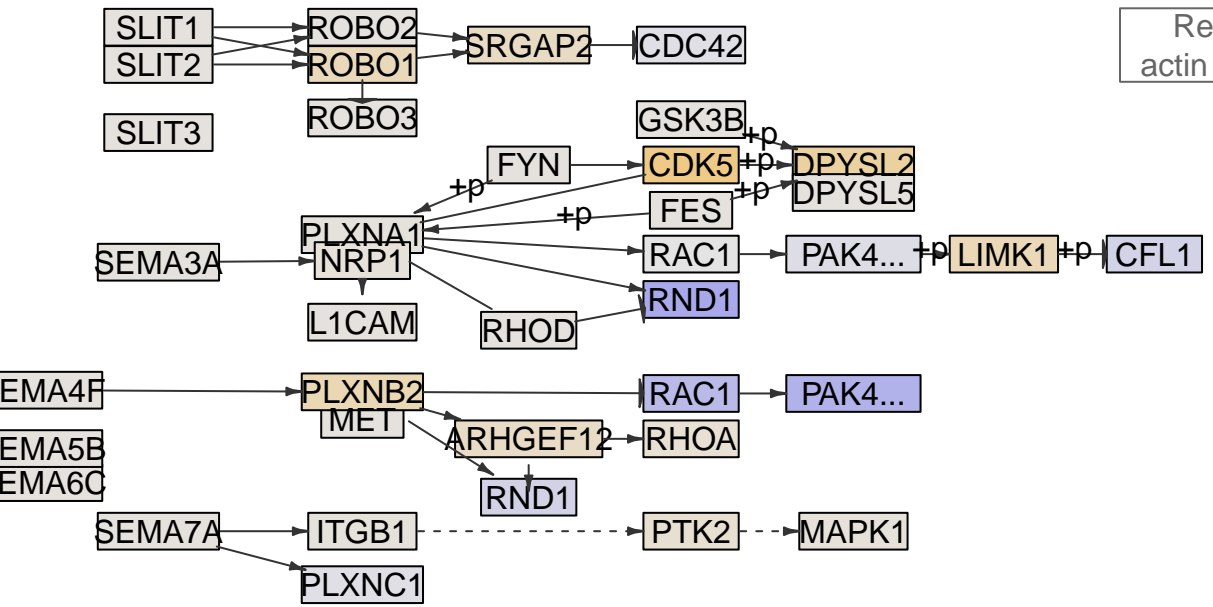

Regulation of actin cytoskeleton

Regulation of actin cytoskeleton

Axon guidance
MPI-146

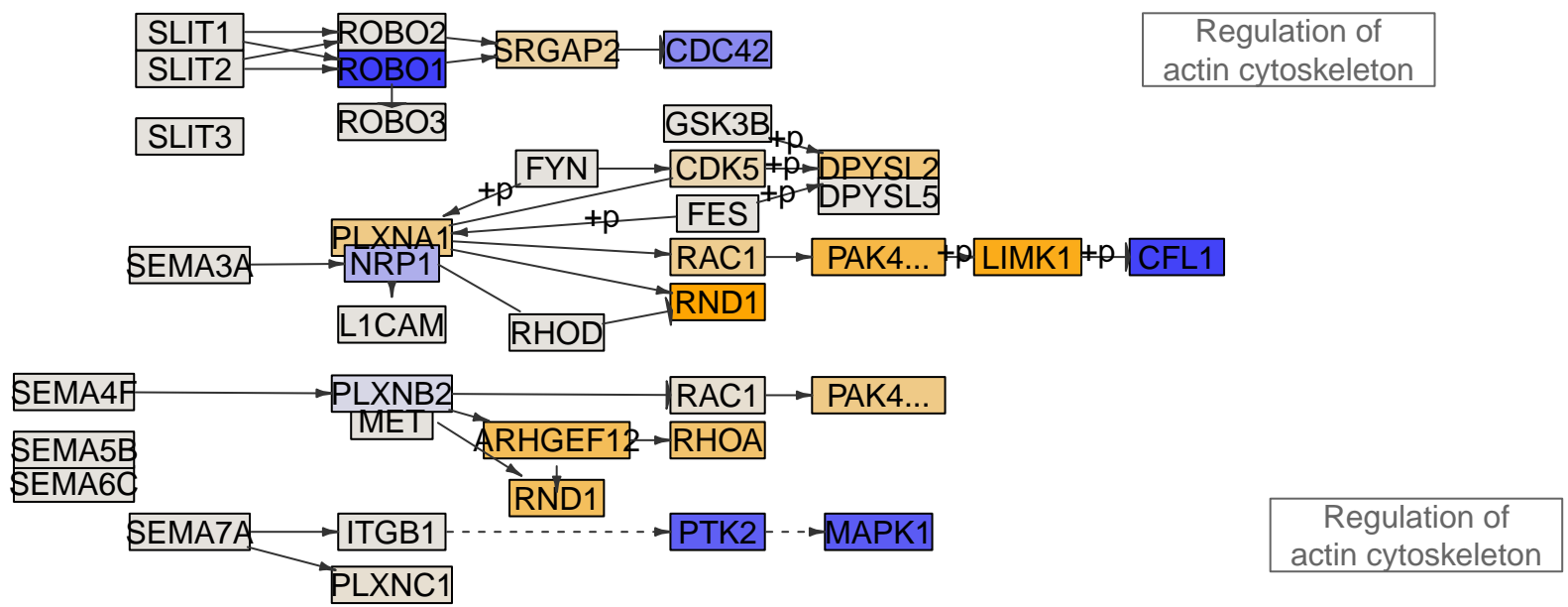
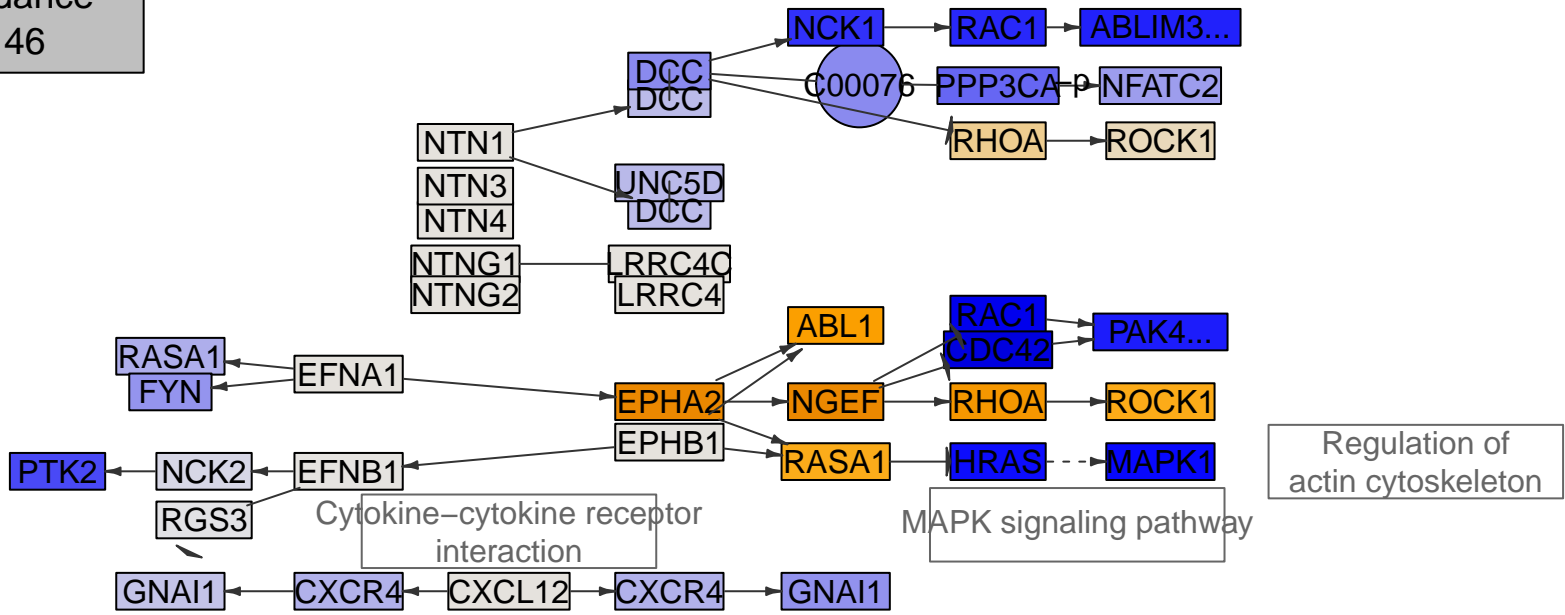

Axon guidance
MPI-149

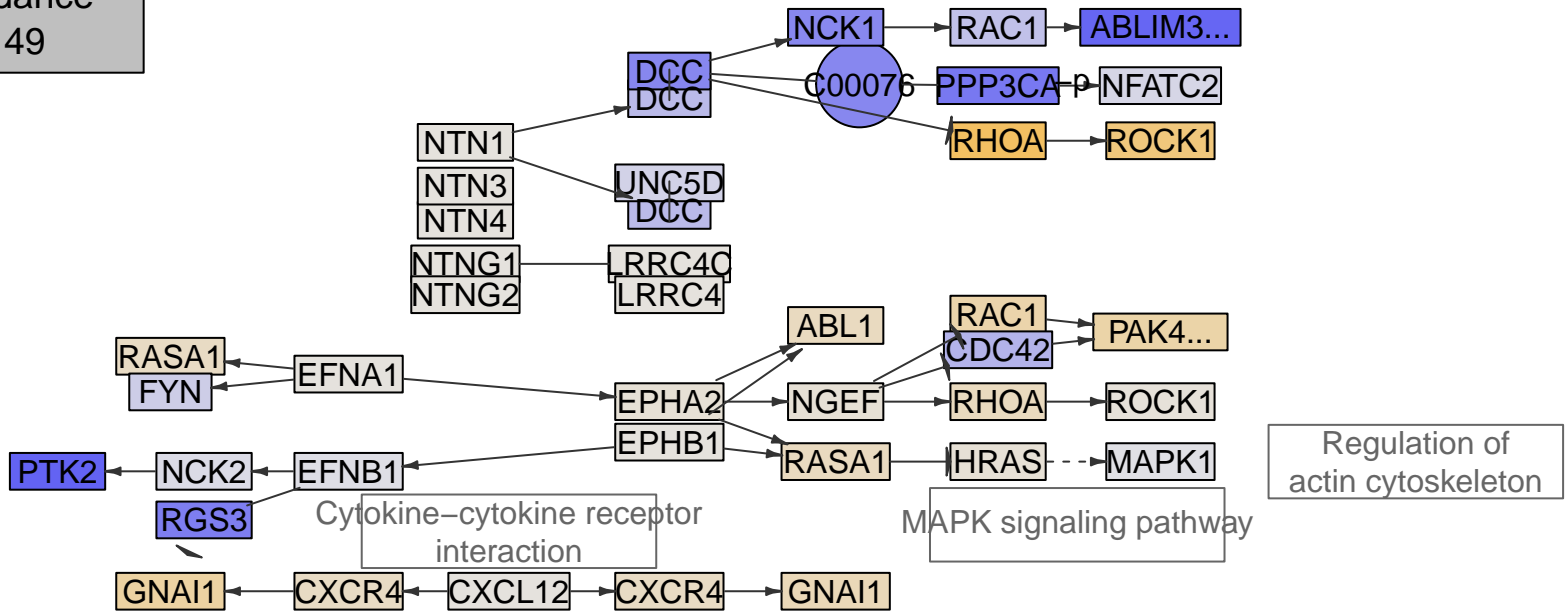

Regulation of actin cytoskeleton

MAPK signaling pathway

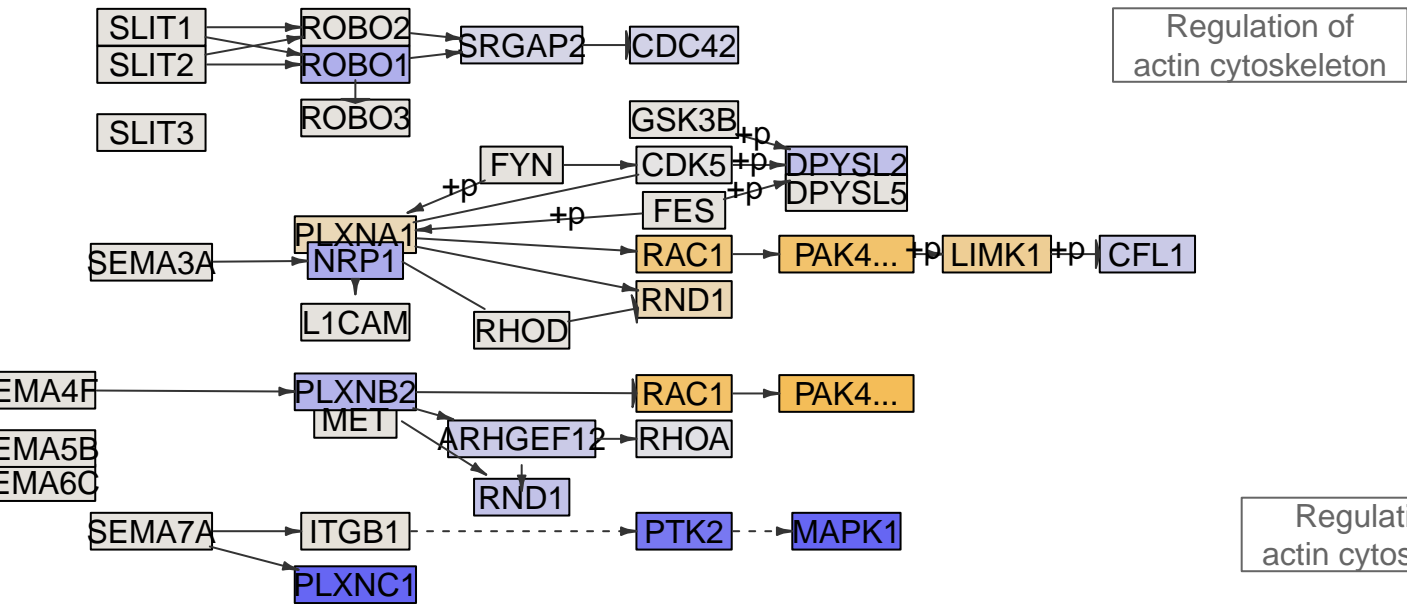

Regulation of actin cytoskeleton

Regulation of actin cytoskeleton

Axon guidance
MPI-150

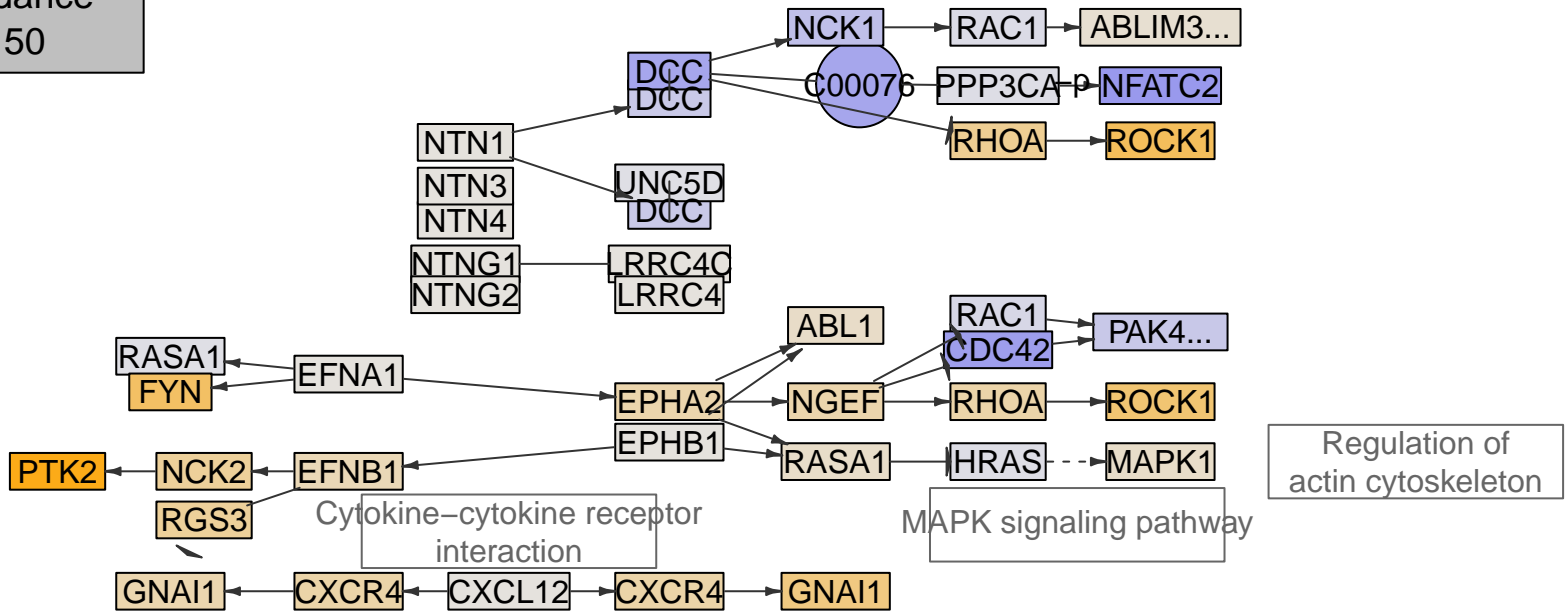

Regulation of actin cytoskeleton

MAPK signaling pathway

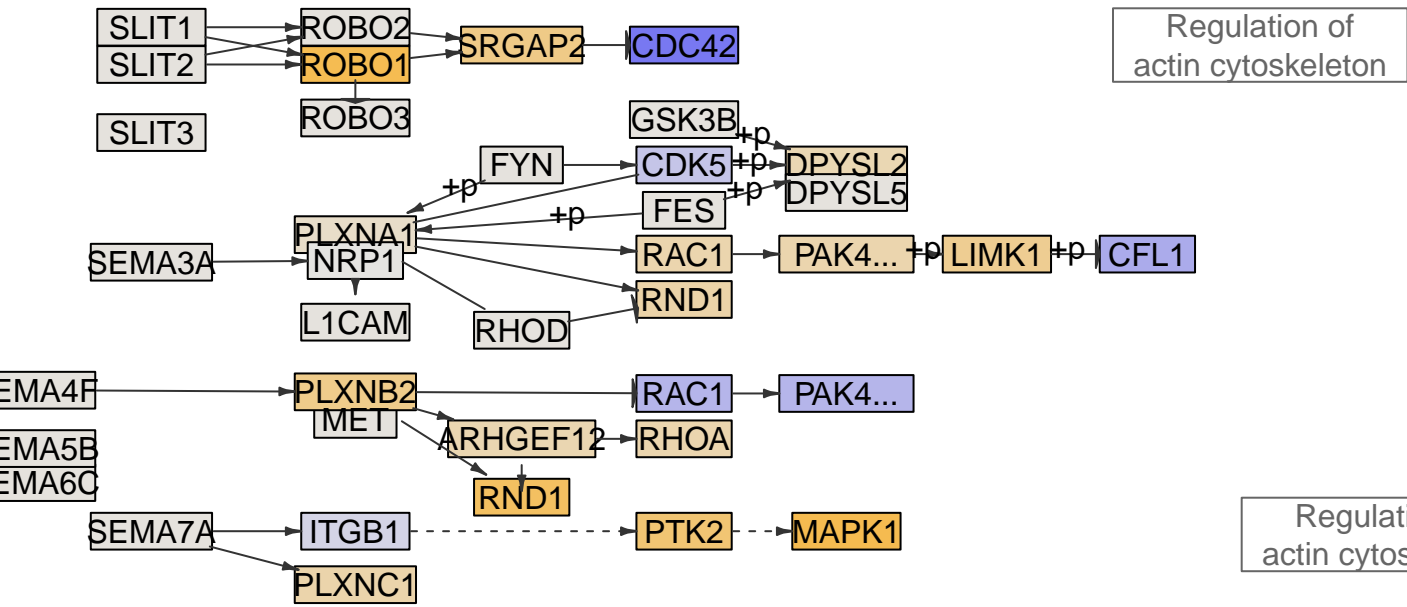

Regulation of actin cytoskeleton

Regulation of actin cytoskeleton

Axon guidance
MPI-151

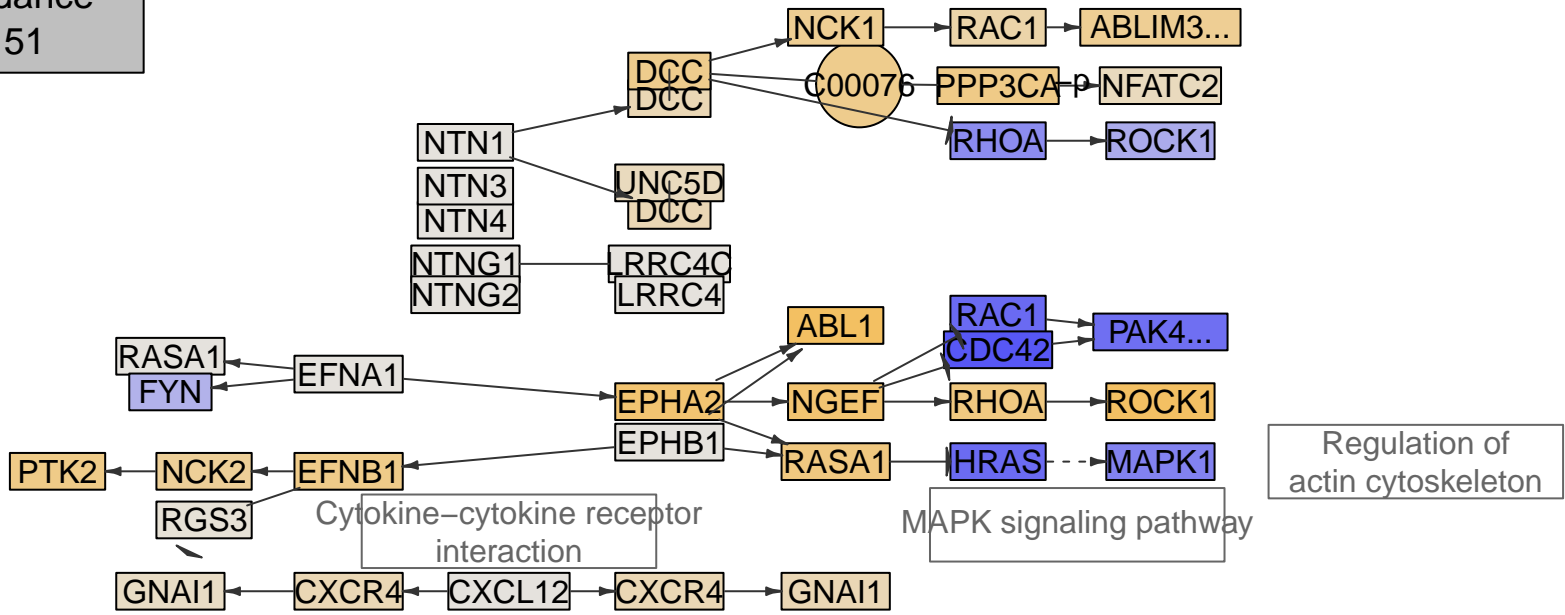

Regulation of actin cytoskeleton

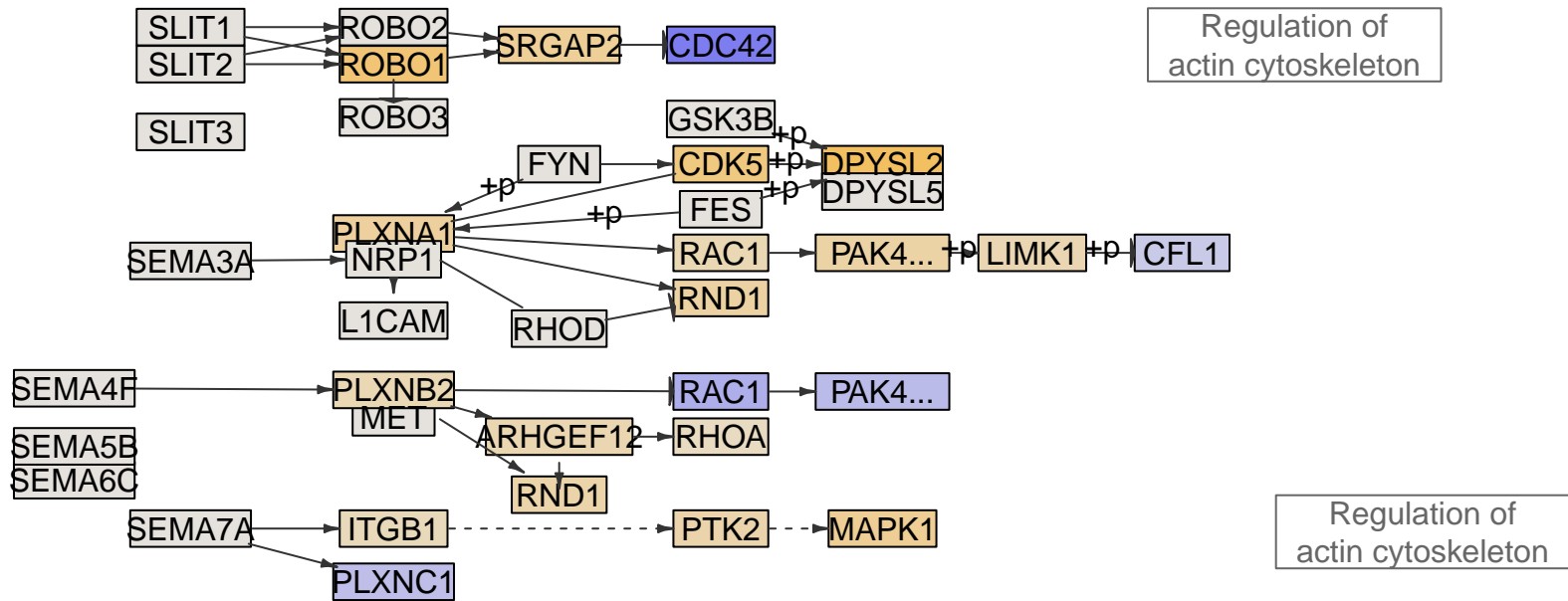

Regulation of actin cytoskeleton

Regulation of actin cytoskeleton

Axon guidance
MPI-152

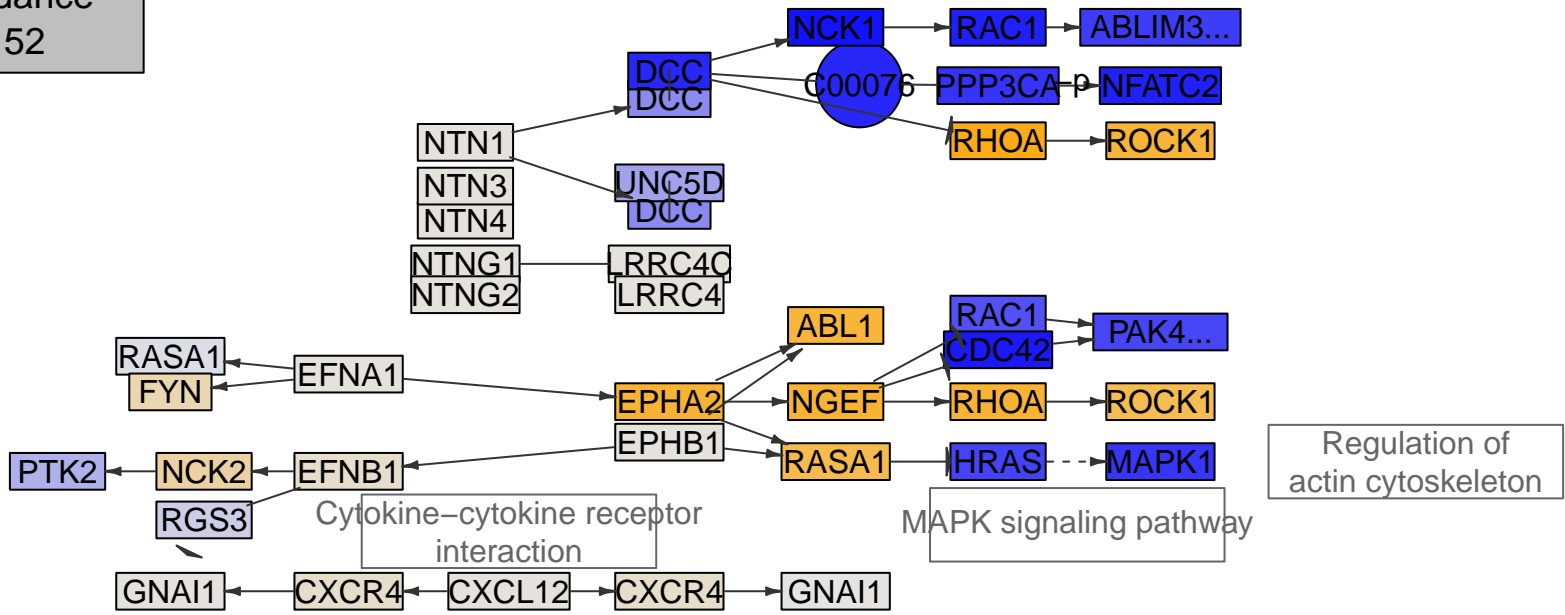

Regulation of actin cytoskeleton

MAPK signaling pathway

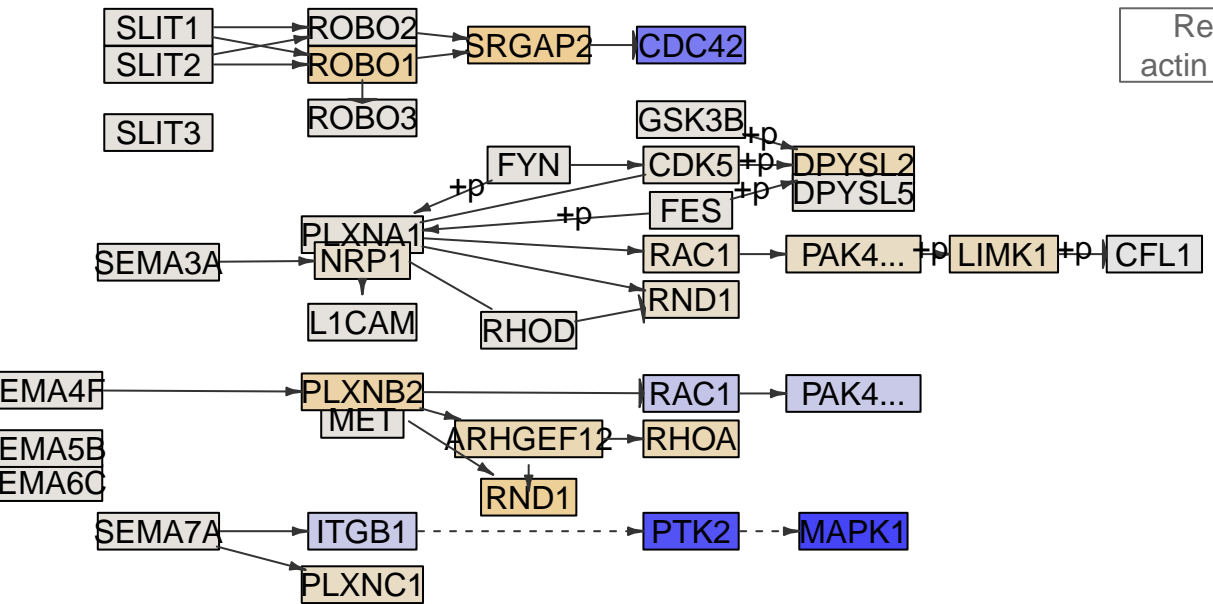

Regulation of actin cytoskeleton

Regulation of actin cytoskeleton

Axon guidance
MPI-153

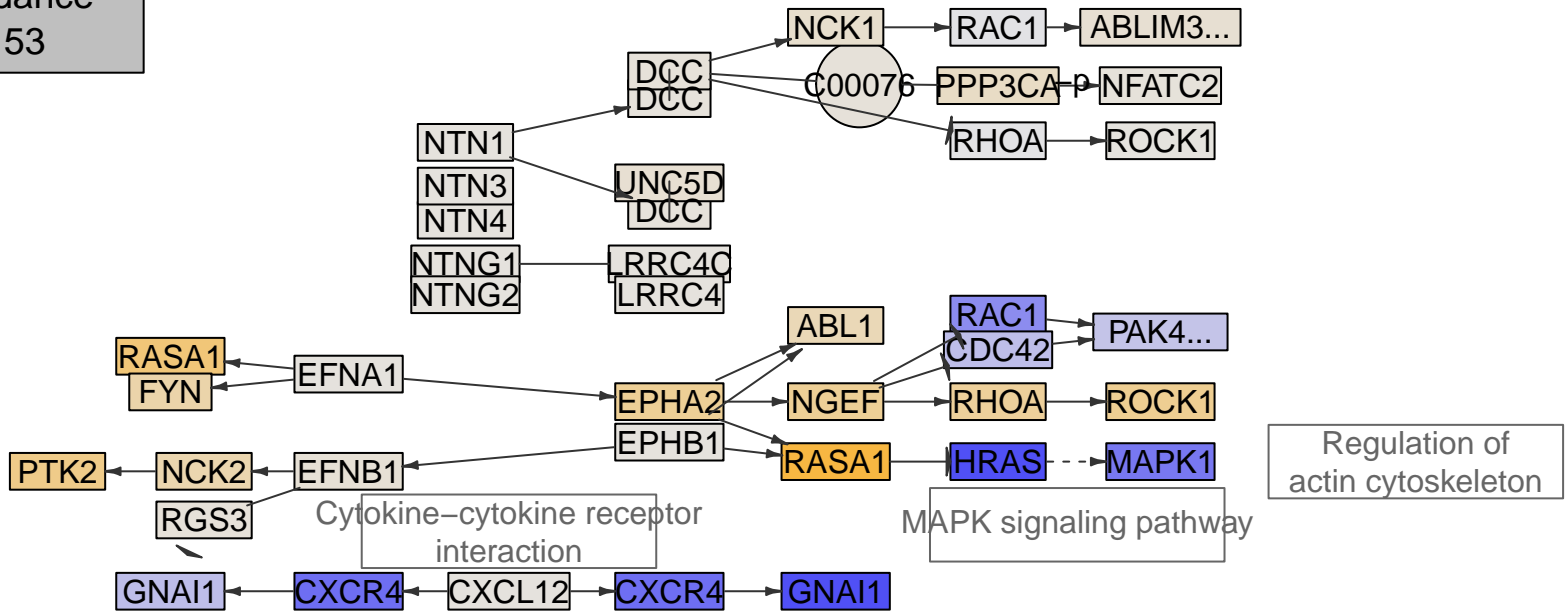

Regulation of actin cytoskeleton

MAPK signaling pathway

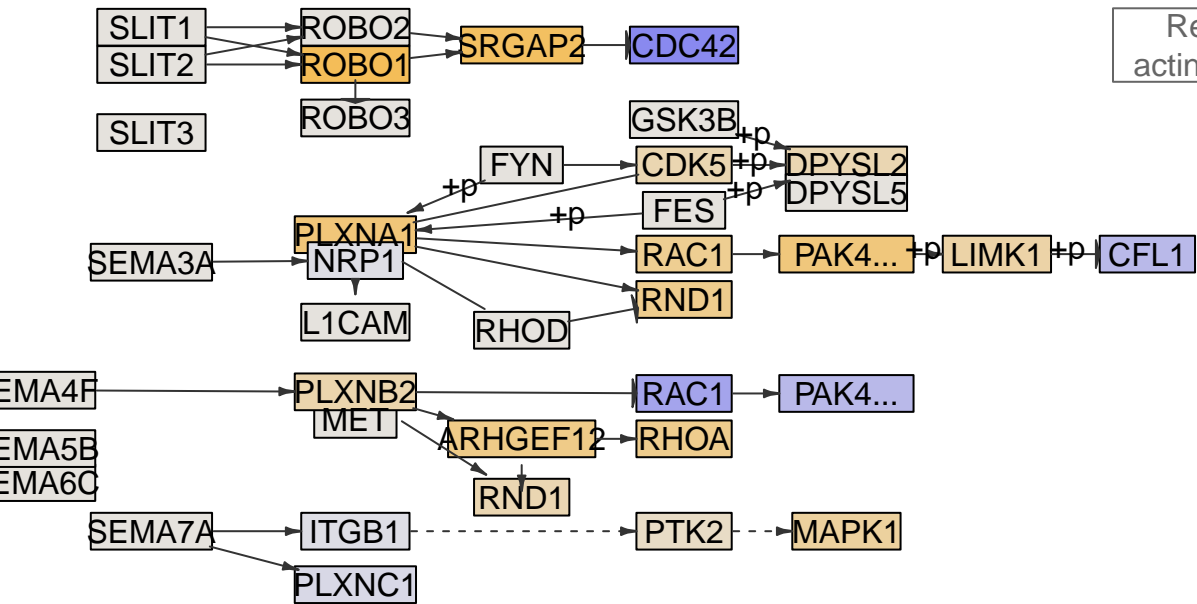

Regulation of actin cytoskeleton

Regulation of actin cytoskeleton

Axon guidance
MPI-154

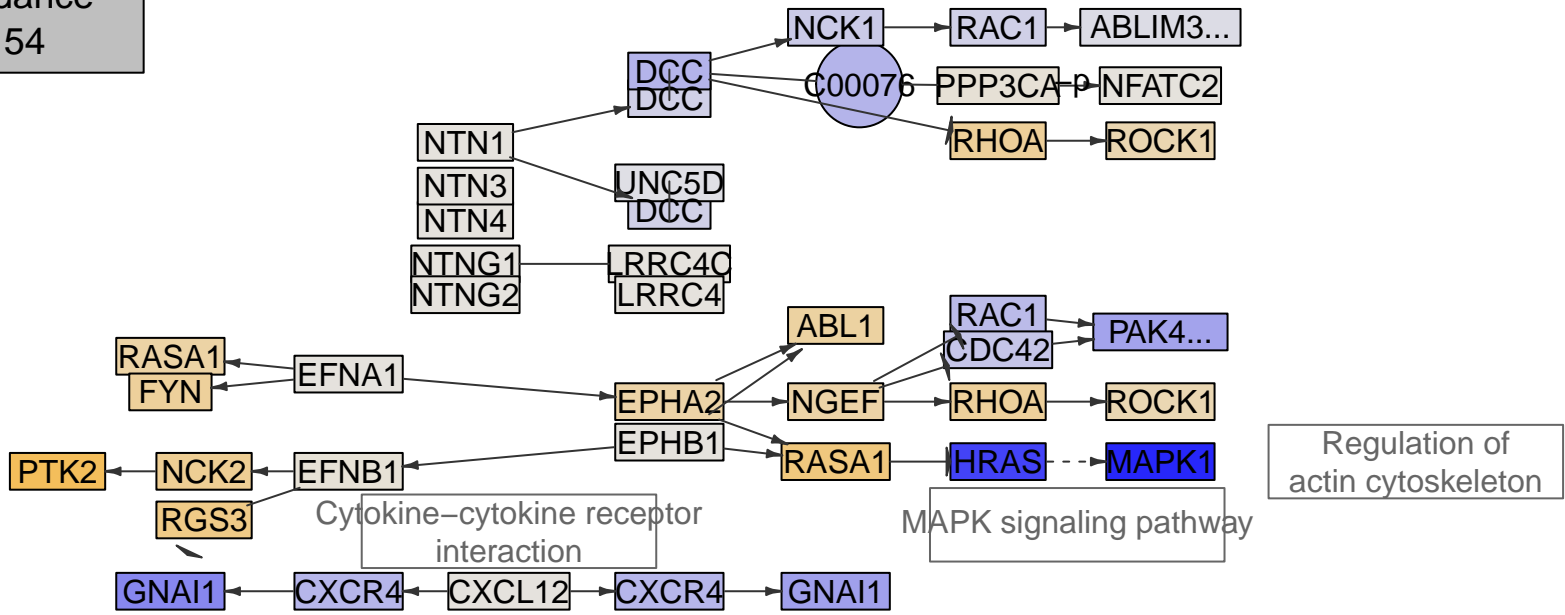

Regulation of actin cytoskeleton

MAPK signaling pathway

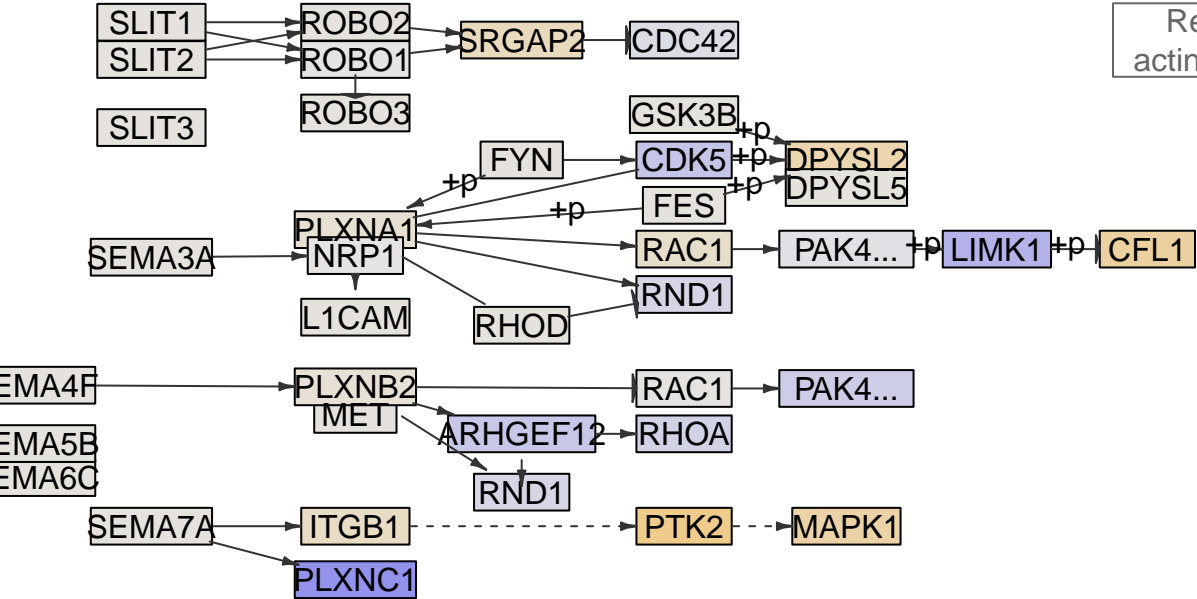

Regulation of actin cytoskeleton

Regulation of actin cytoskeleton

Axon guidance
MPI-155

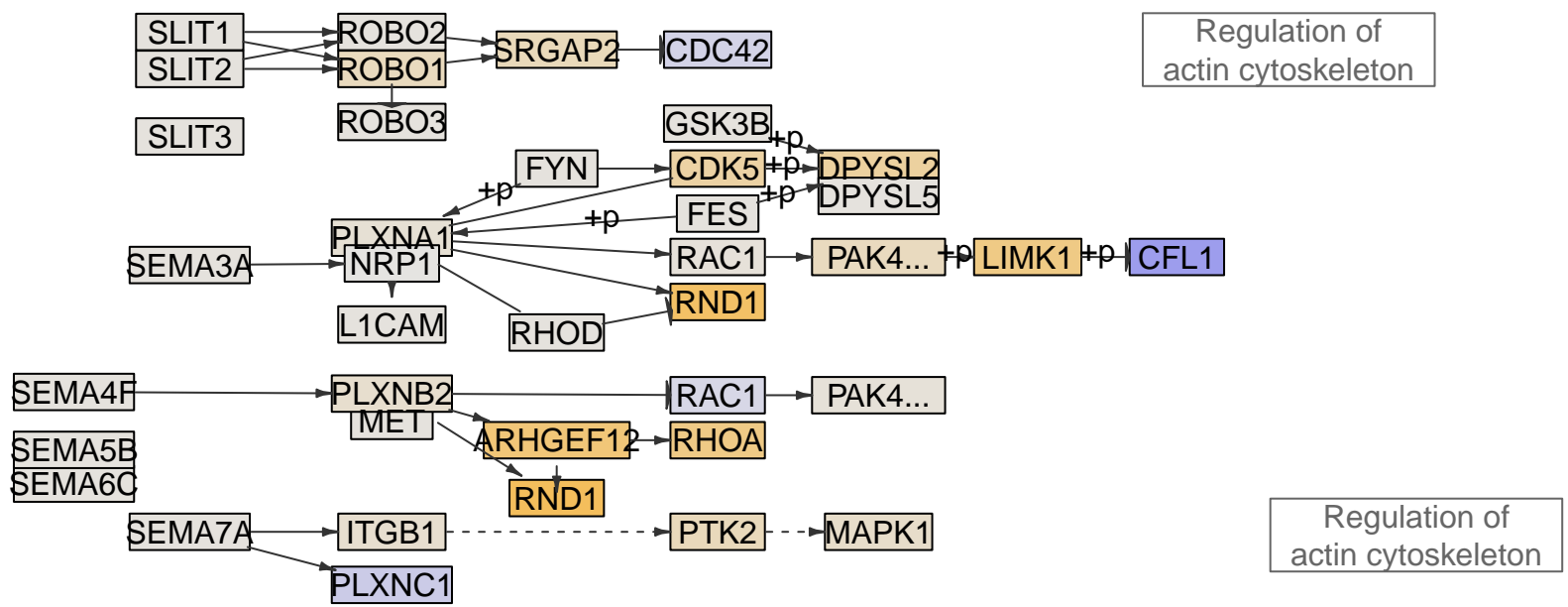
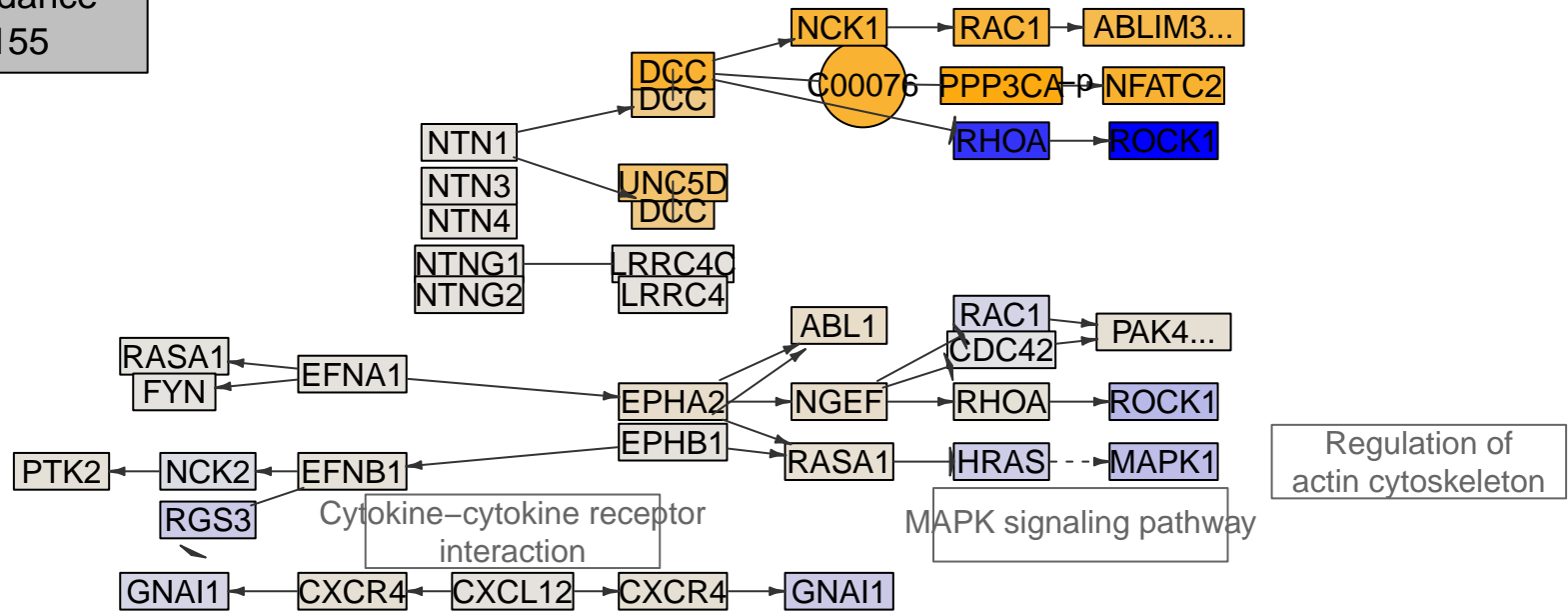

Axon guidance
MPI-159

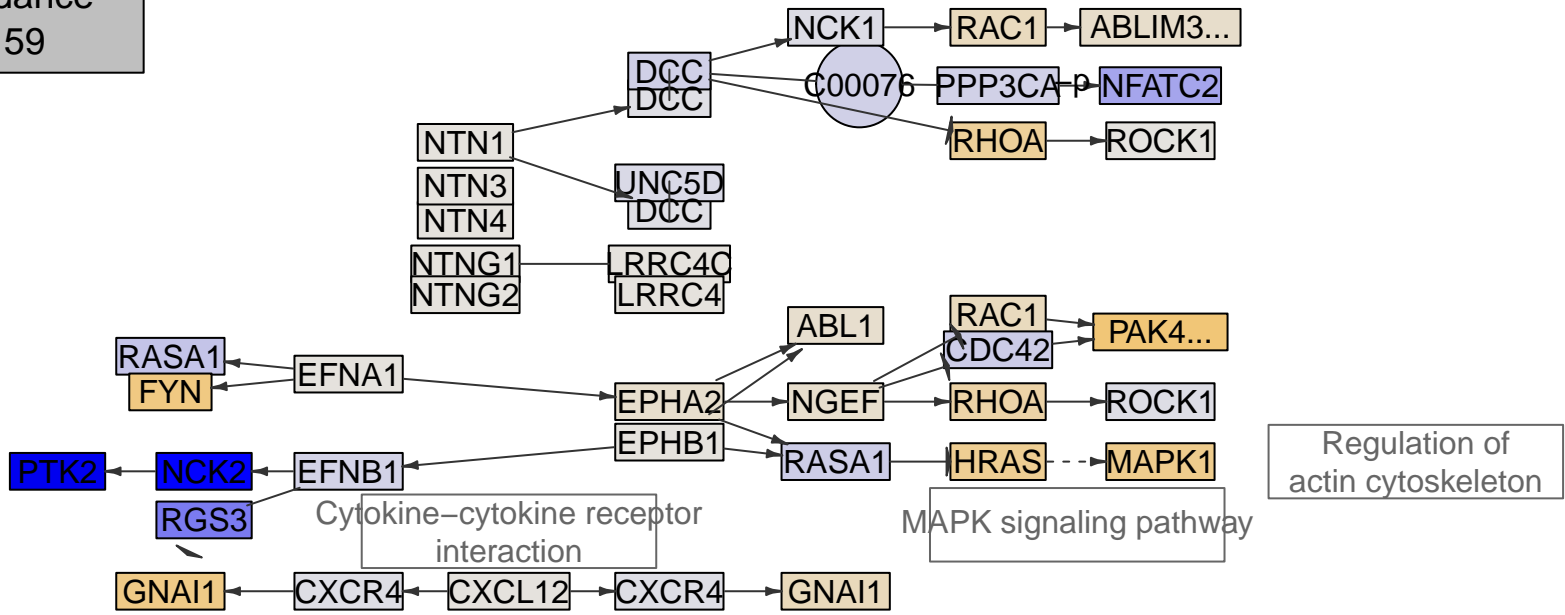

Regulation of actin cytoskeleton

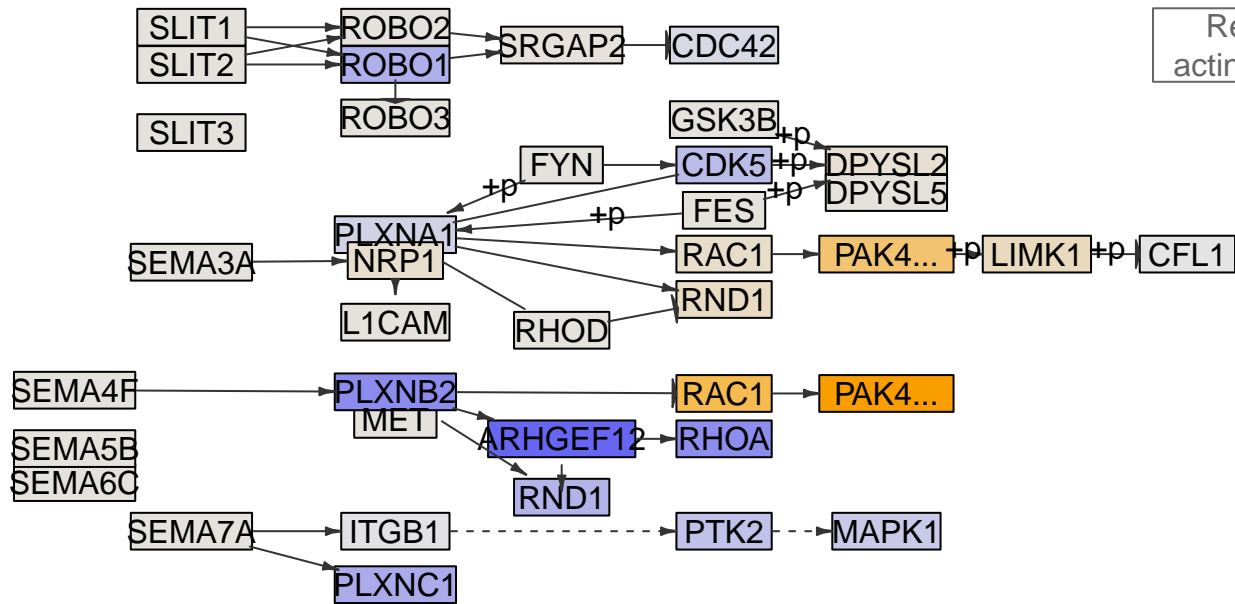

Regulation of actin cytoskeleton

Regulation of actin cytoskeleton

Axon guidance
MPI-163

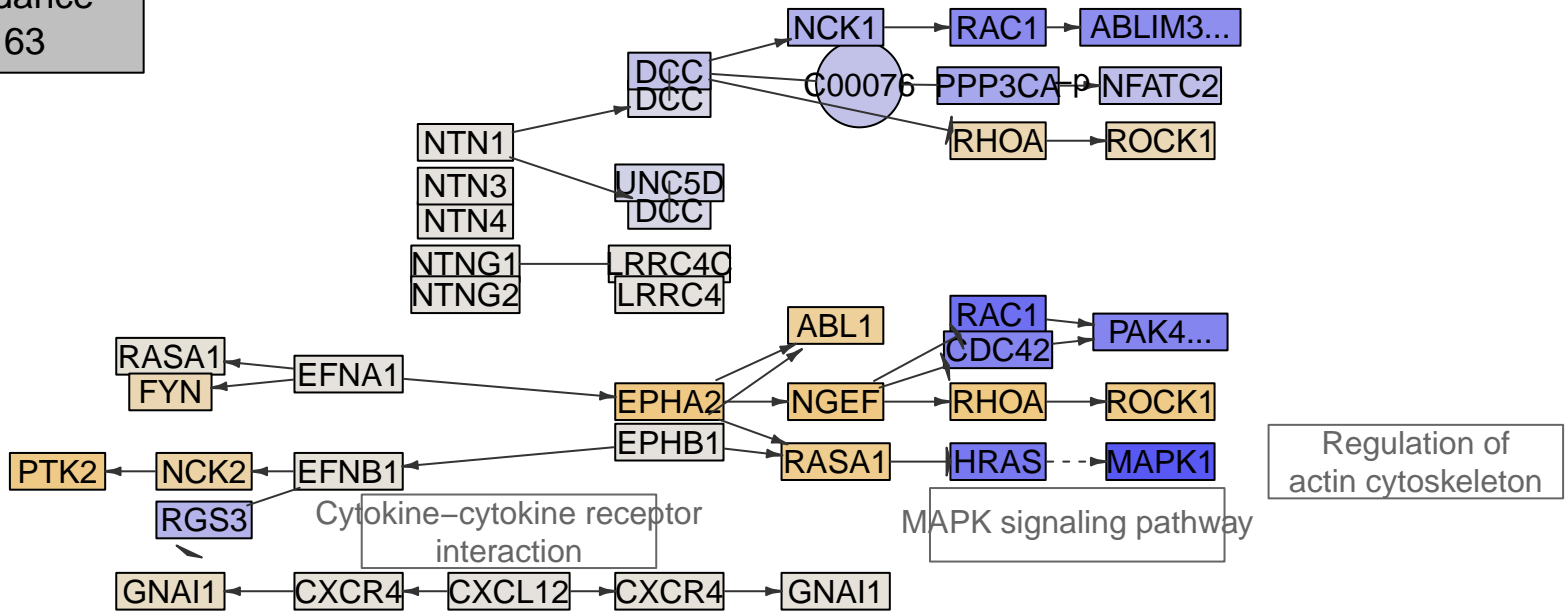

Regulation of actin cytoskeleton

MAPK signaling pathway

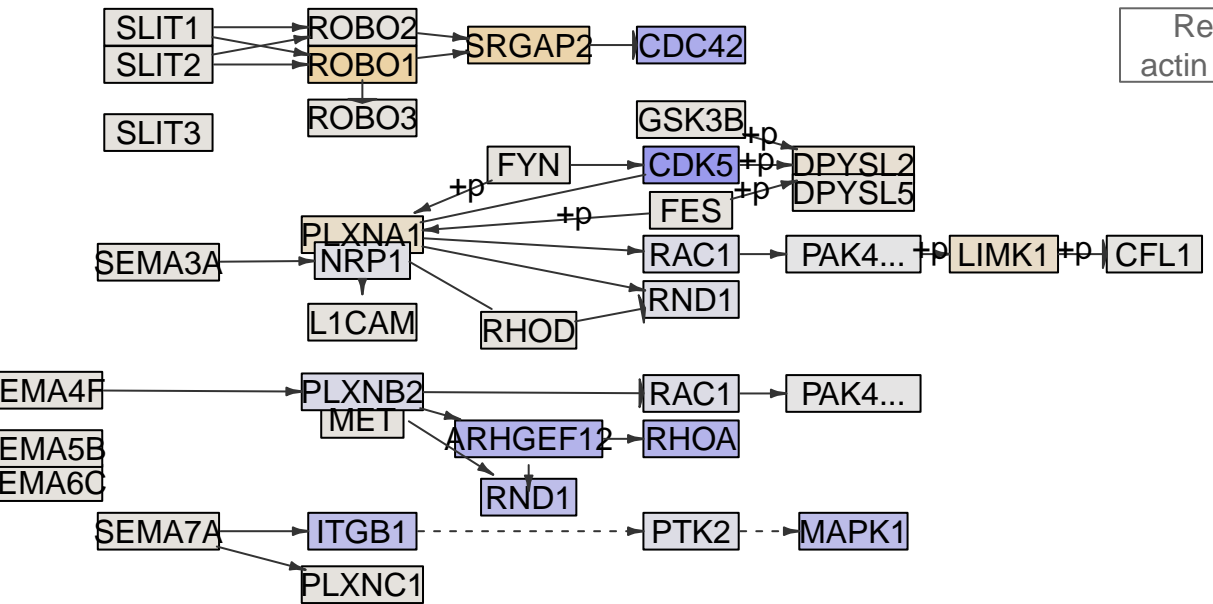

Regulation of actin cytoskeleton

Regulation of actin cytoskeleton

Axon guidance
MPI-164

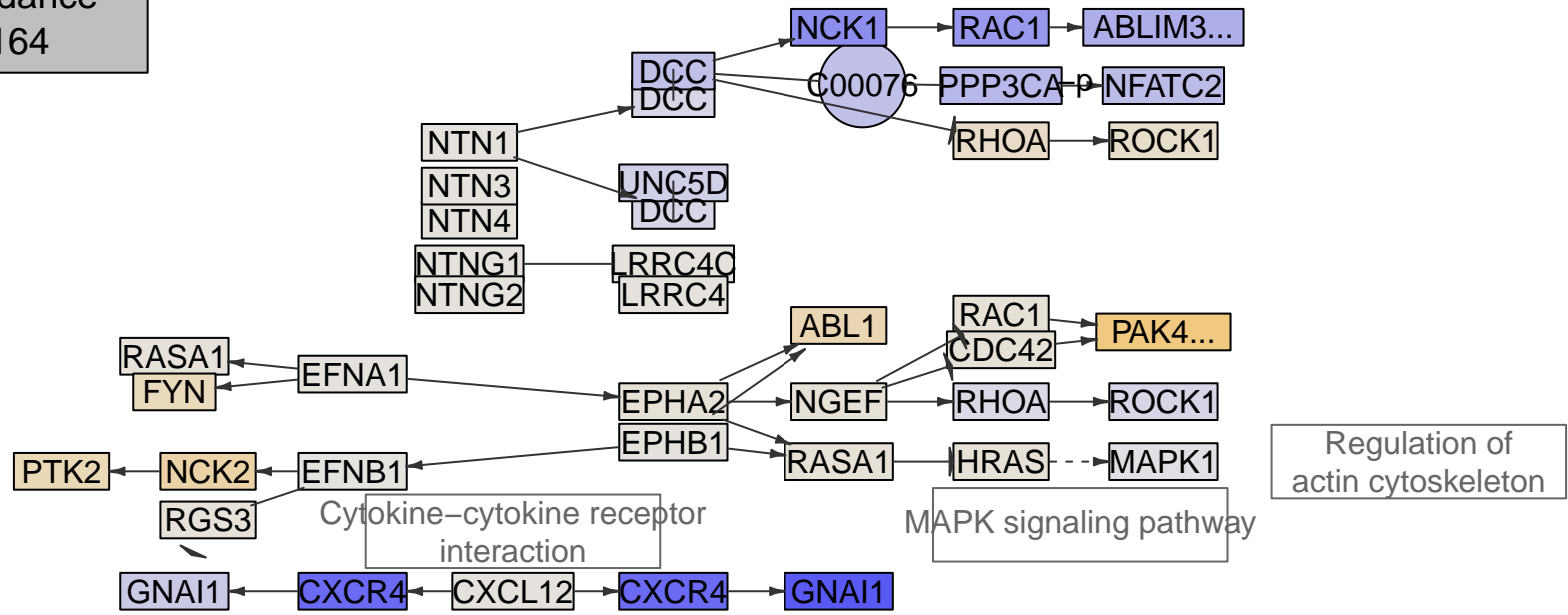

Regulation of actin cytoskeleton

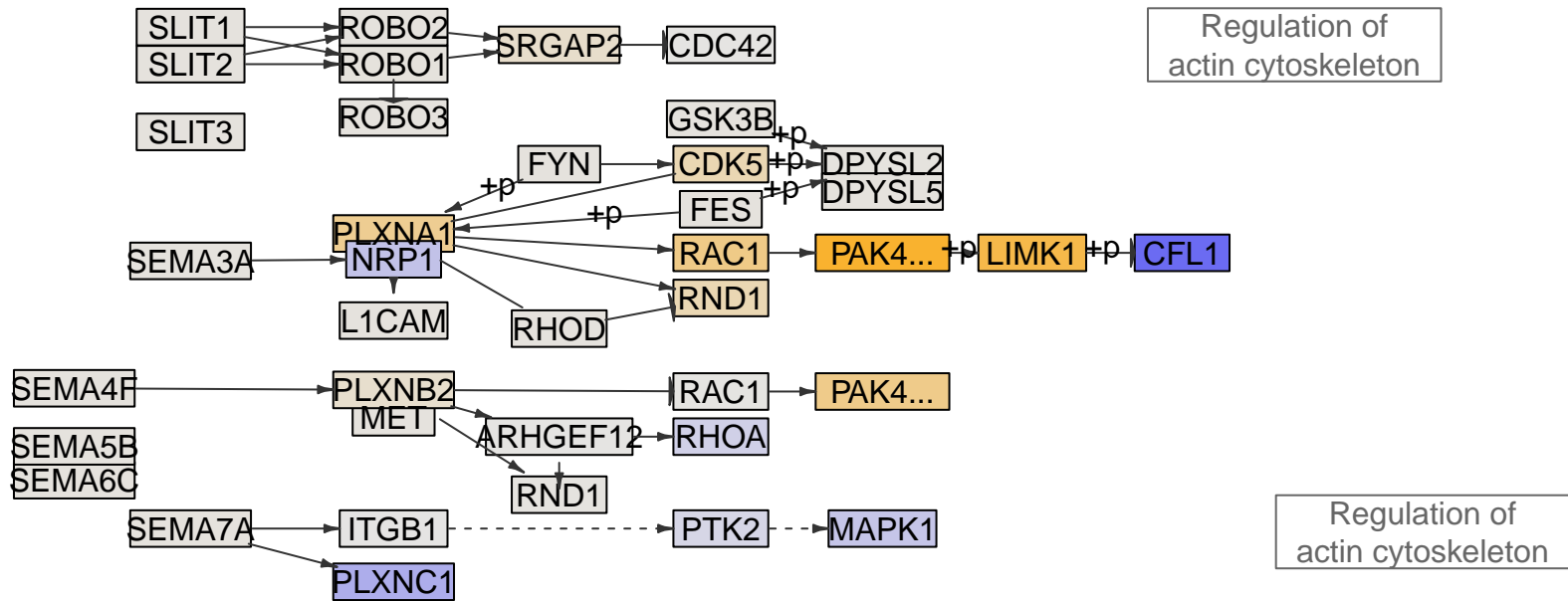

Regulation of actin cytoskeleton

Regulation of actin cytoskeleton

Axon guidance
MPI-166

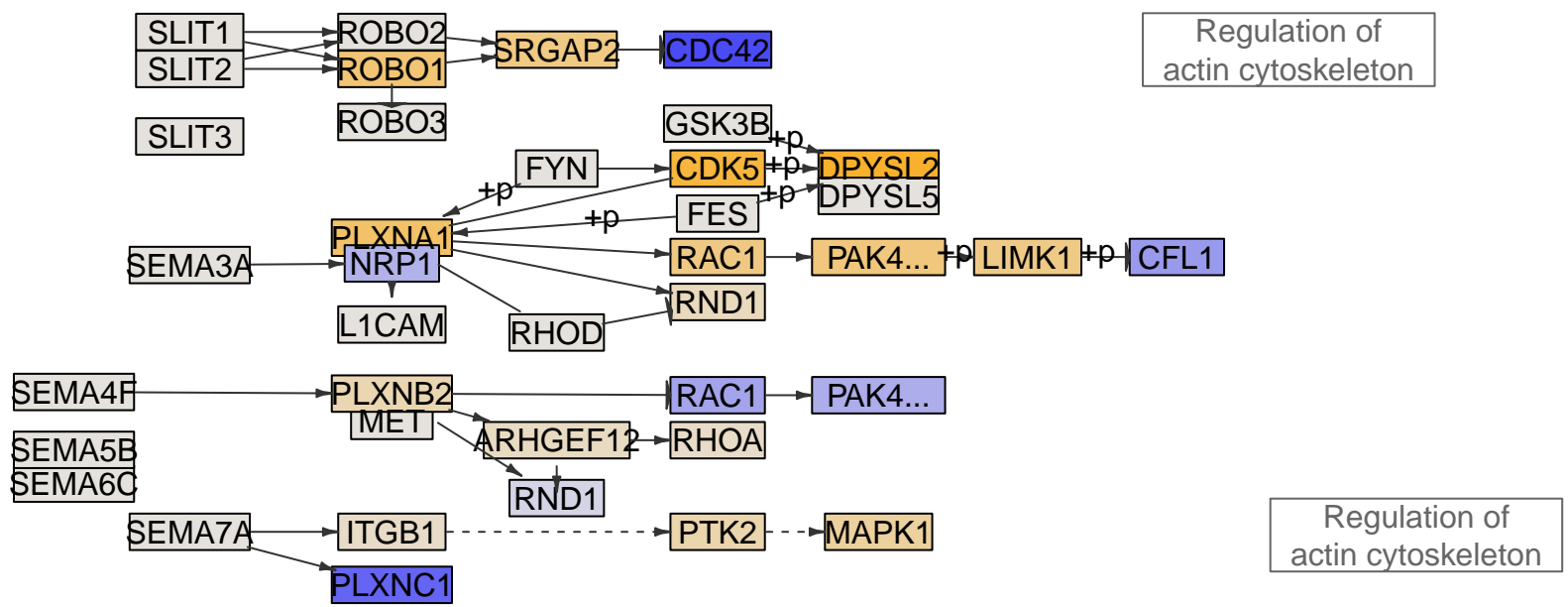
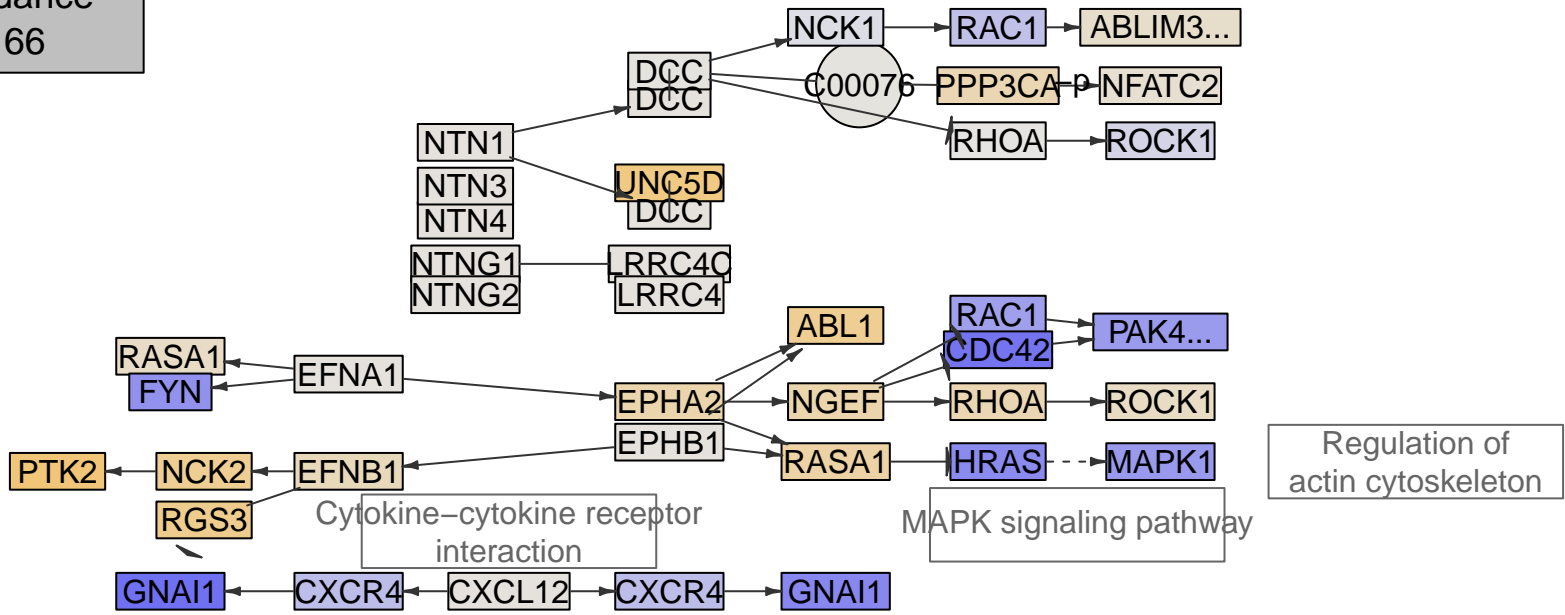

Axon guidance
MPI-167

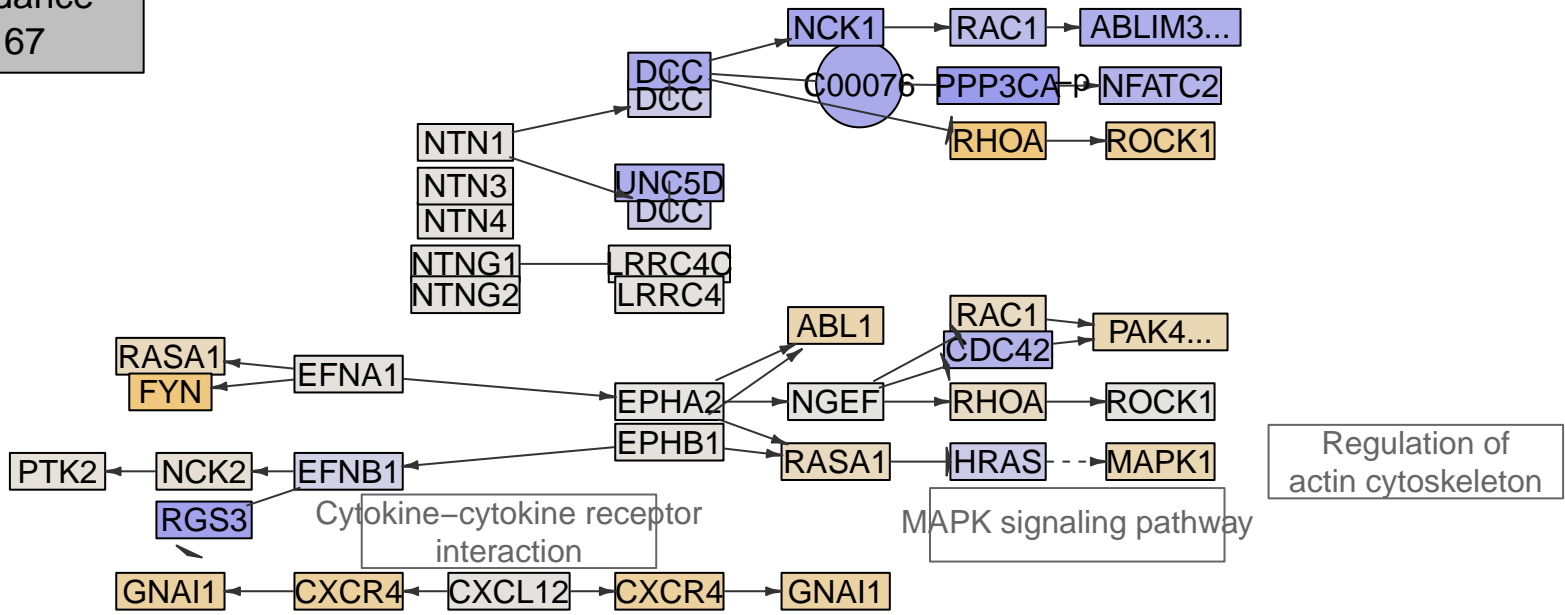

Regulation of actin cytoskeleton

MAPK signaling pathway

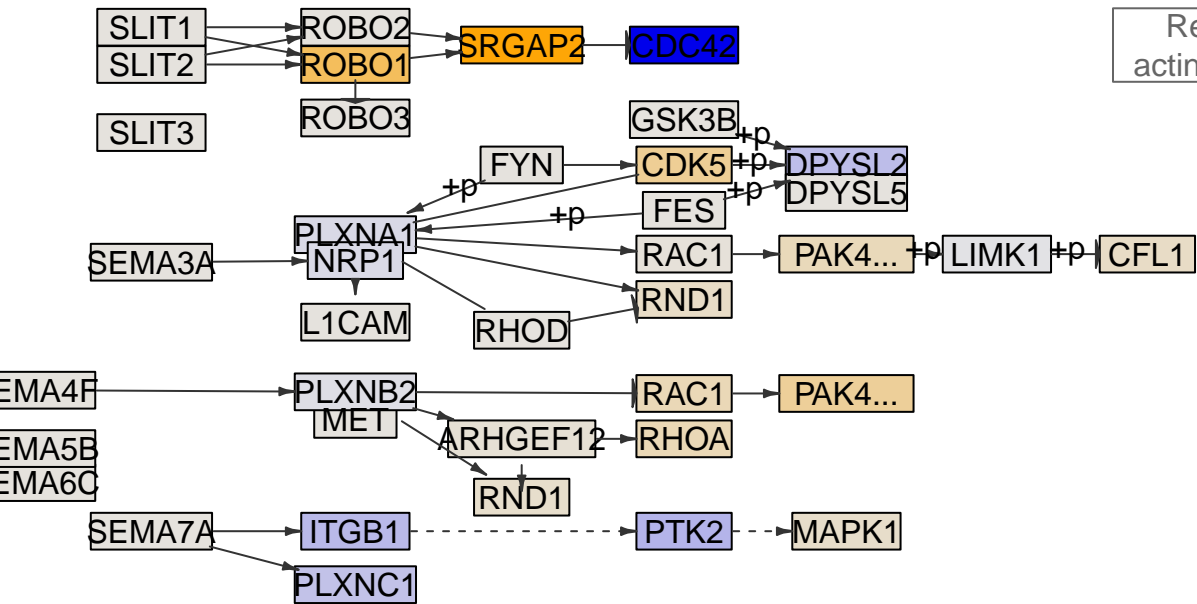

Regulation of actin cytoskeleton

Regulation of actin cytoskeleton

Axon guidance
MPI-168

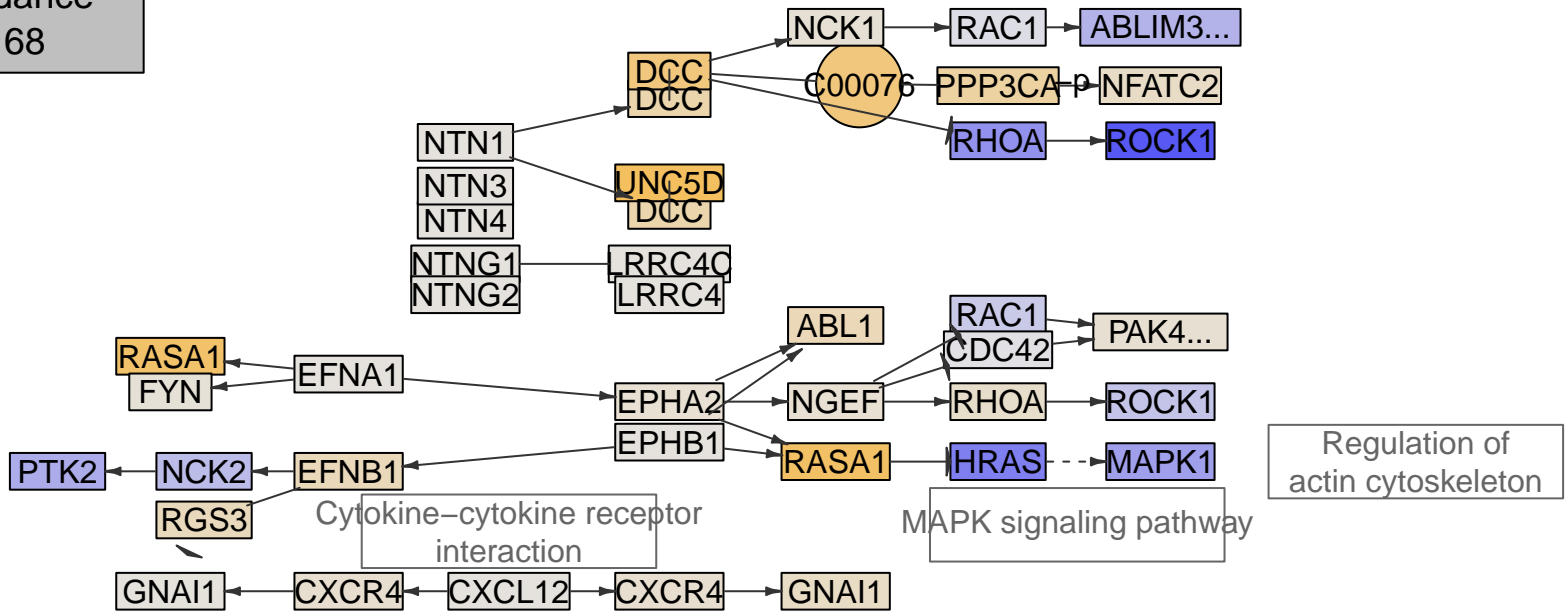

Regulation of actin cytoskeleton

MAPK signaling pathway

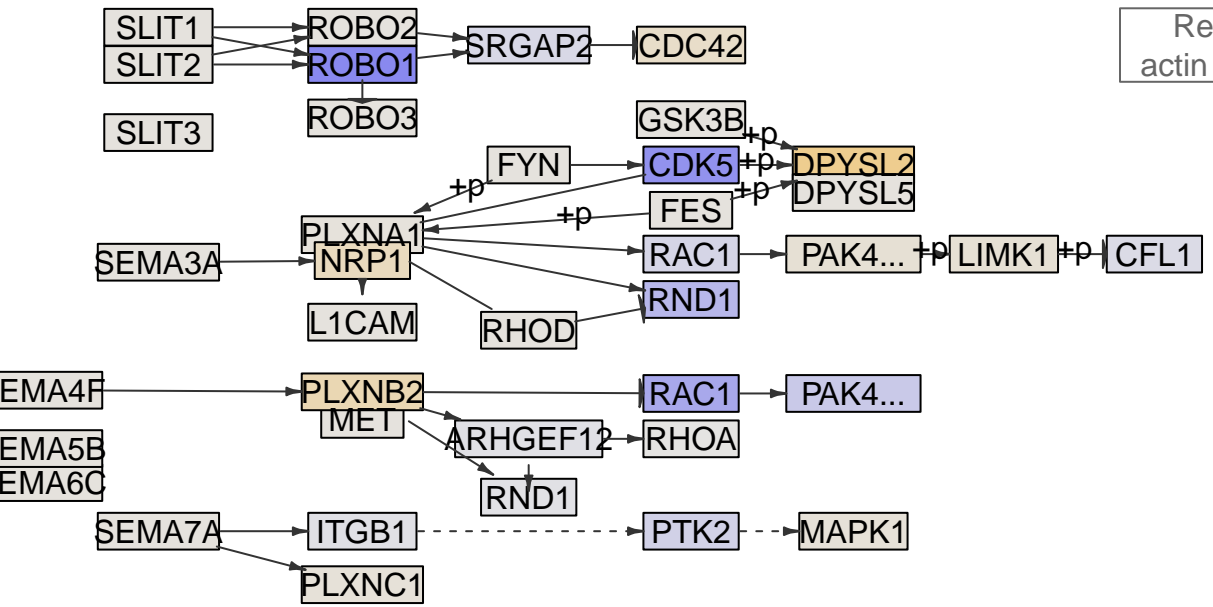

Regulation of actin cytoskeleton

Regulation of actin cytoskeleton

Axon guidance
MPI-170

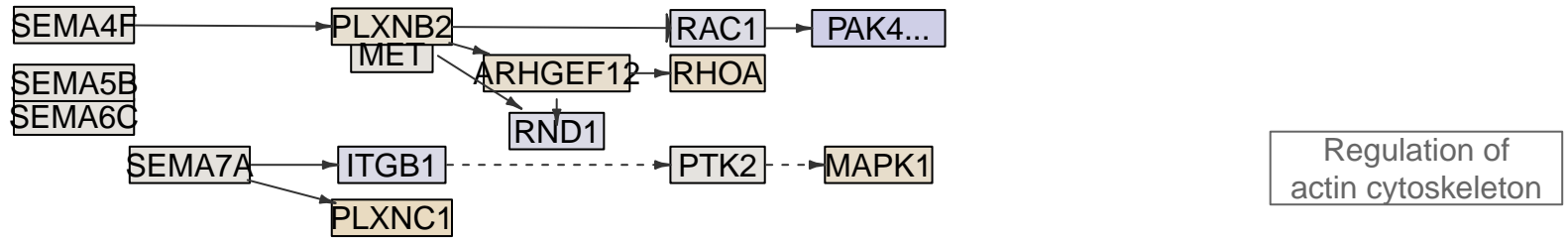
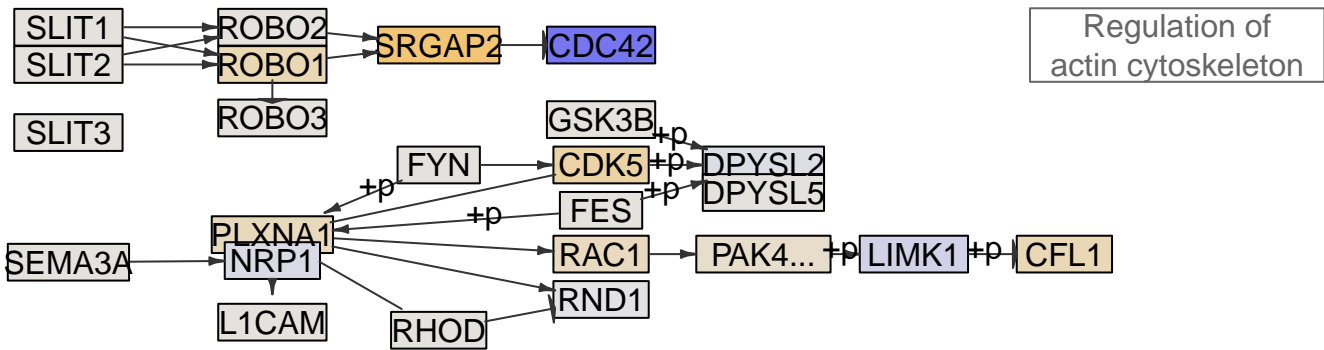
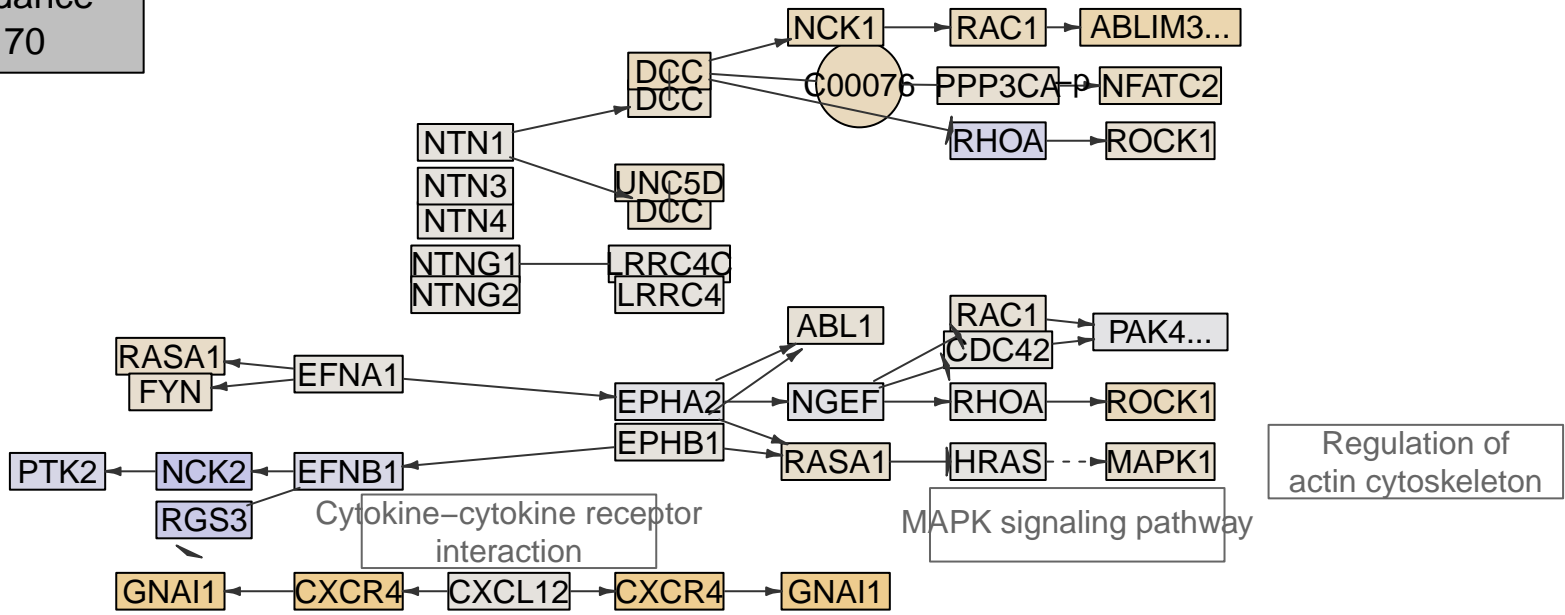

Axon guidance
MPI-173

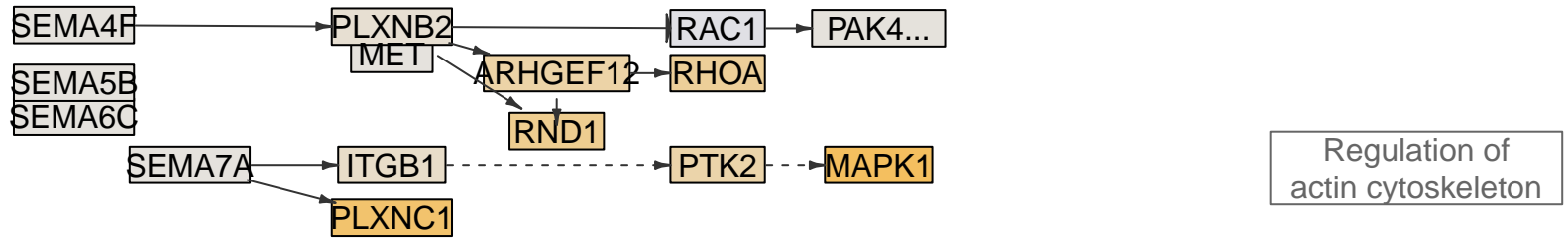
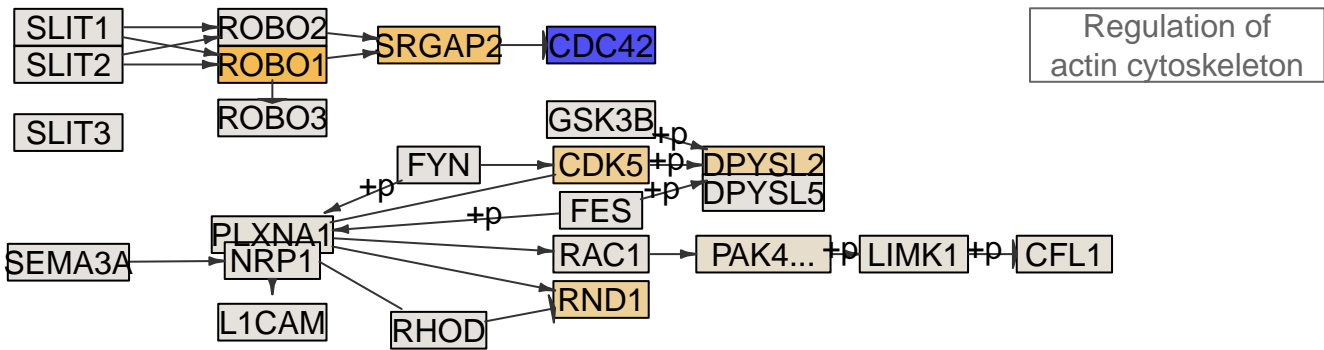
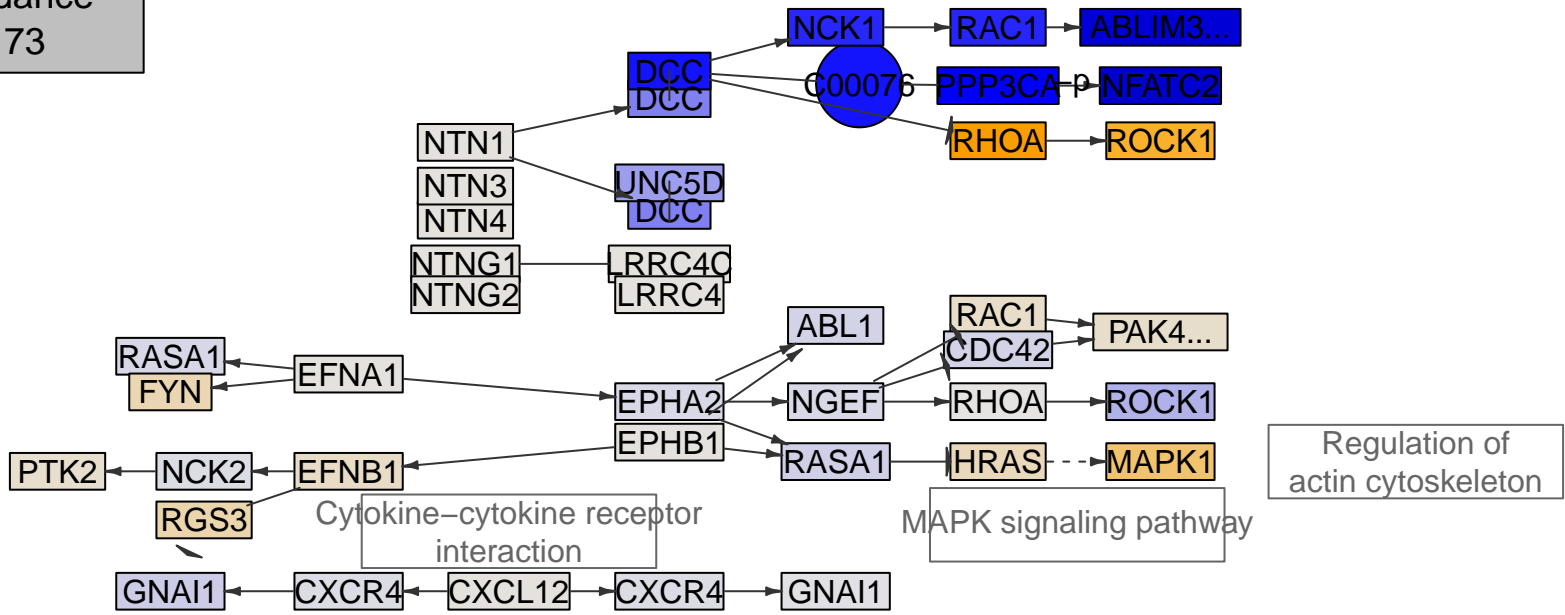

Axon guidance
MPI-174

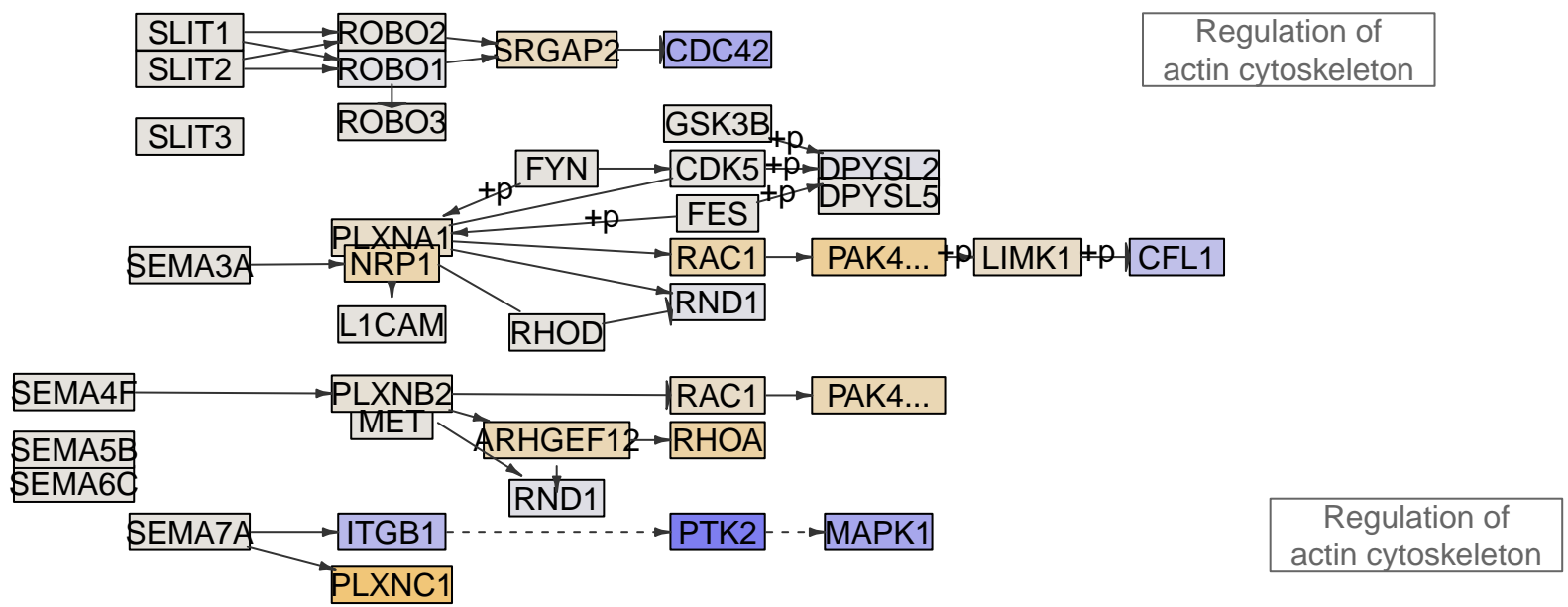
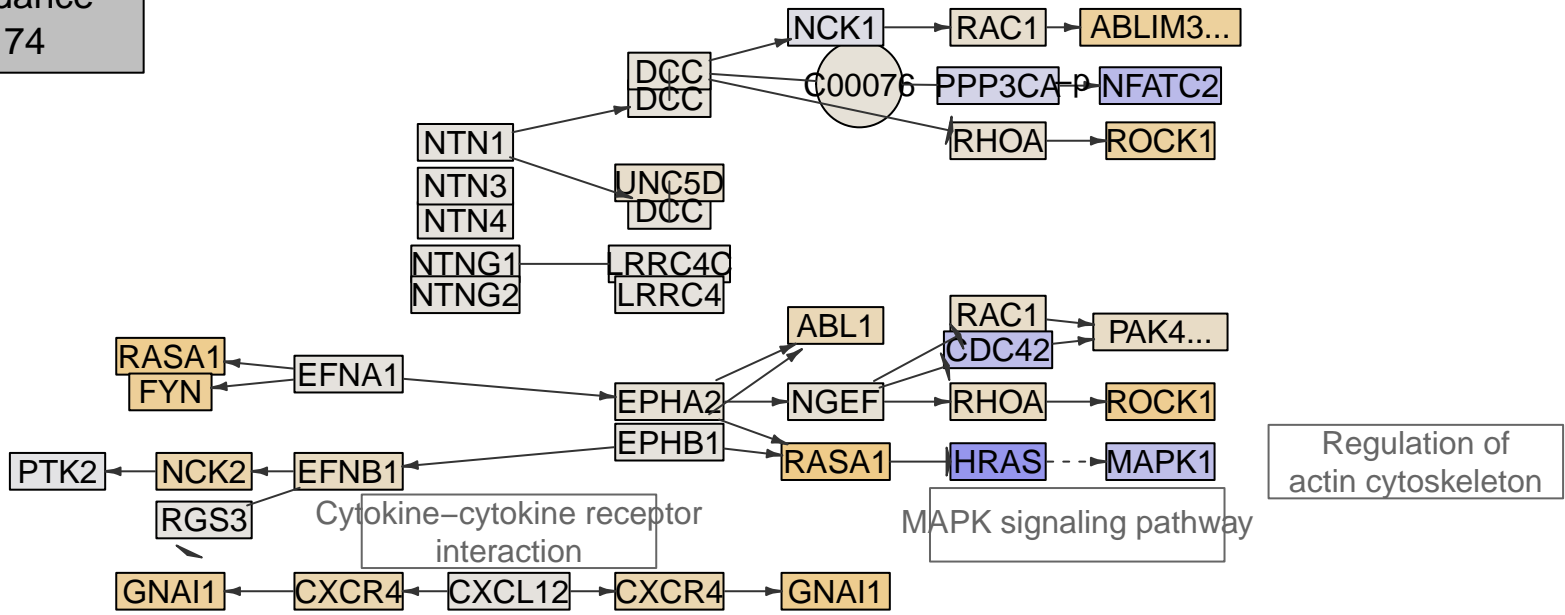

Axon guidance
MPI-176

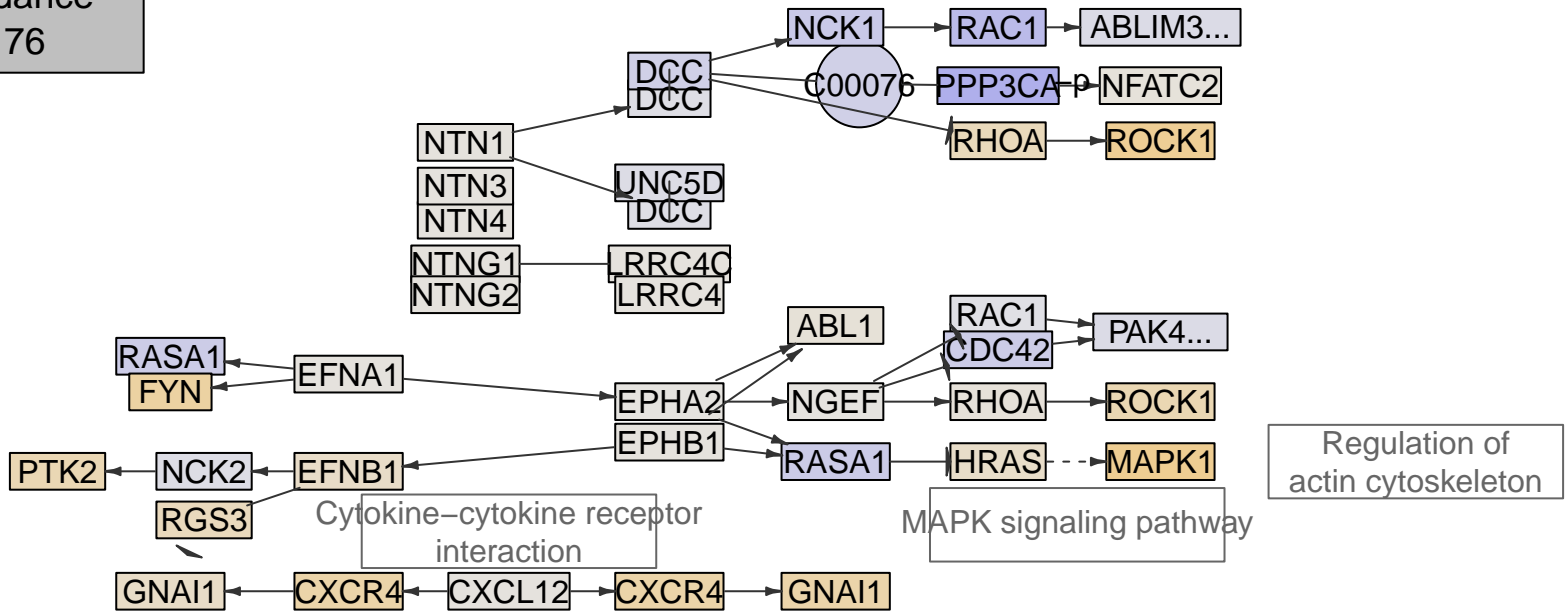

Regulation of actin cytoskeleton

MAPK signaling pathway

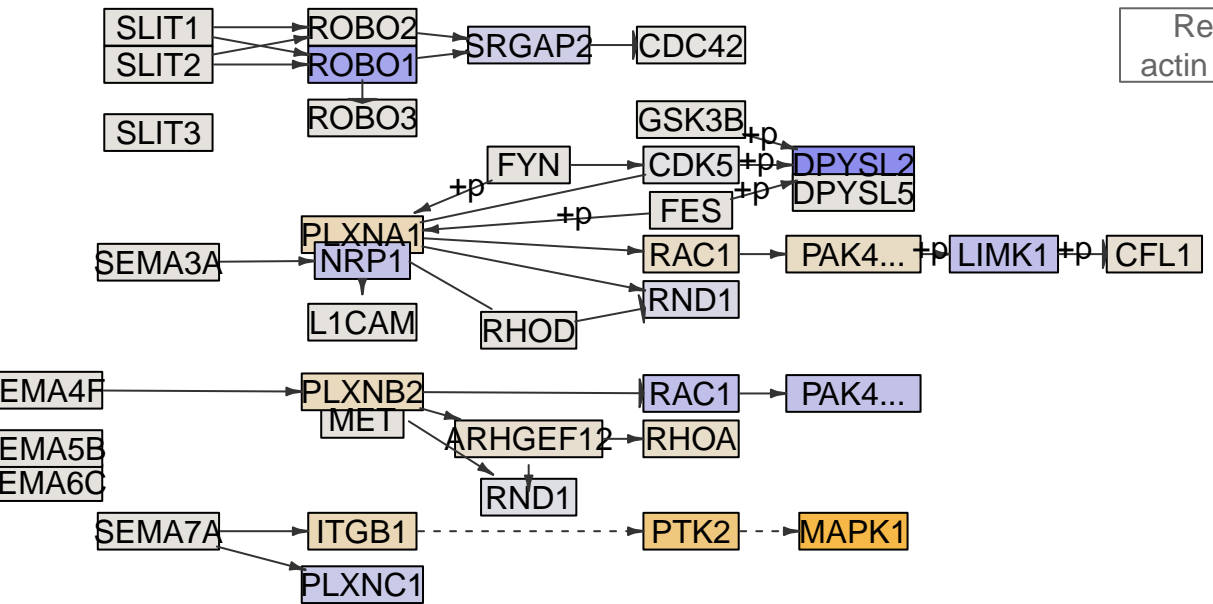

Regulation of actin cytoskeleton

Regulation of actin cytoskeleton

Axon guidance
MPI-177

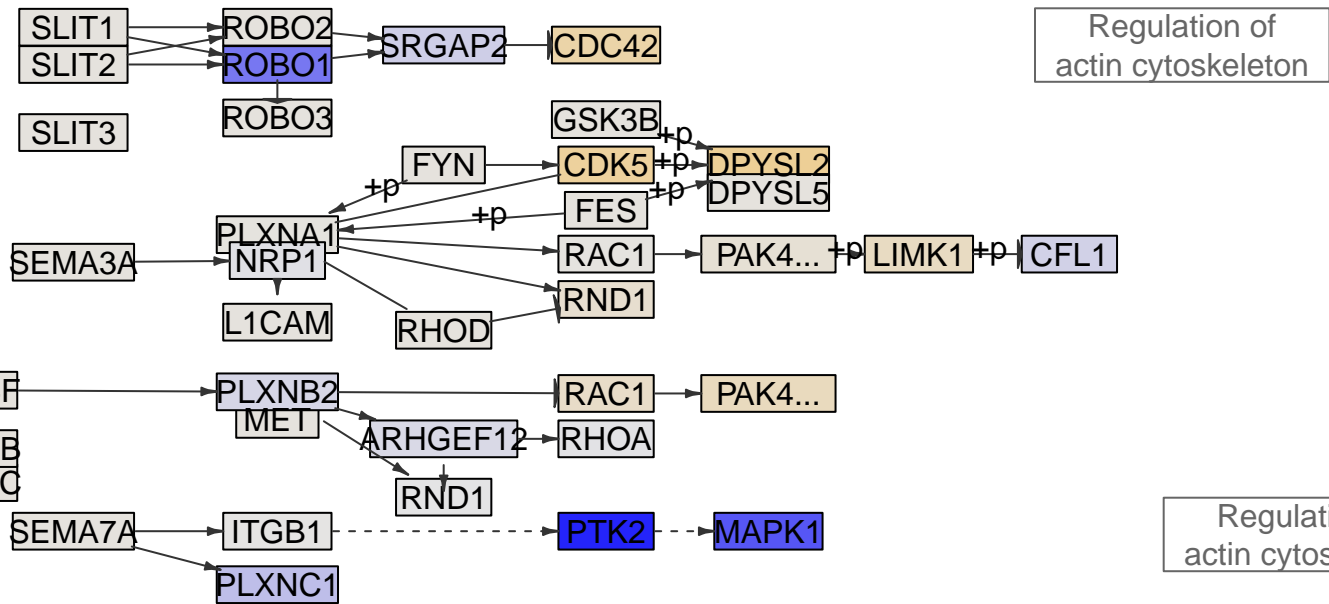
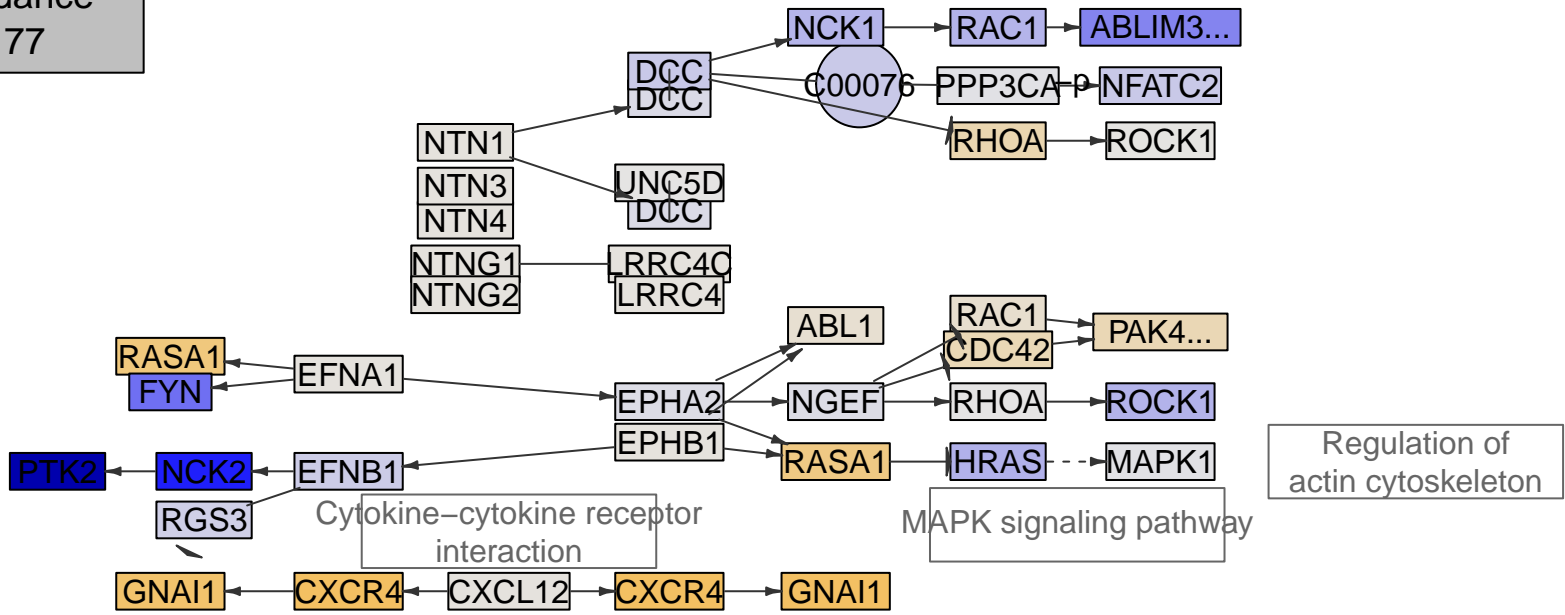

Axon guidance
MPI-178

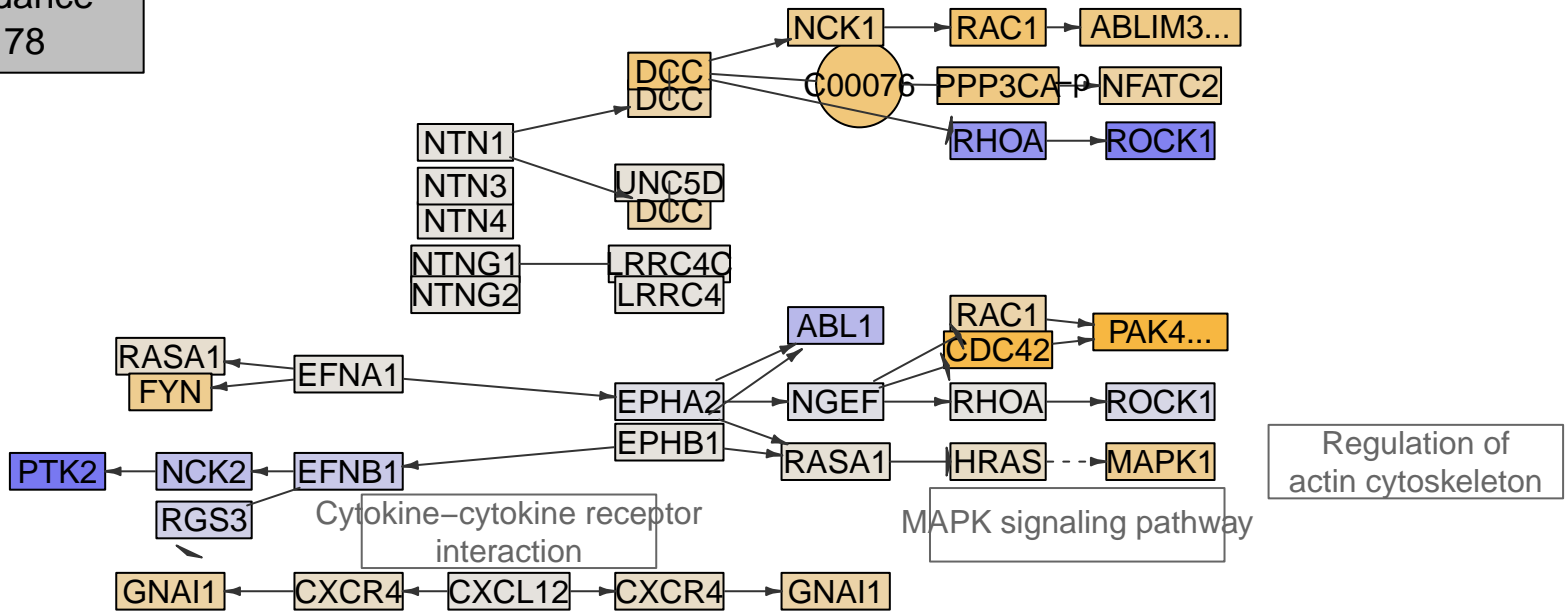

Regulation of actin cytoskeleton

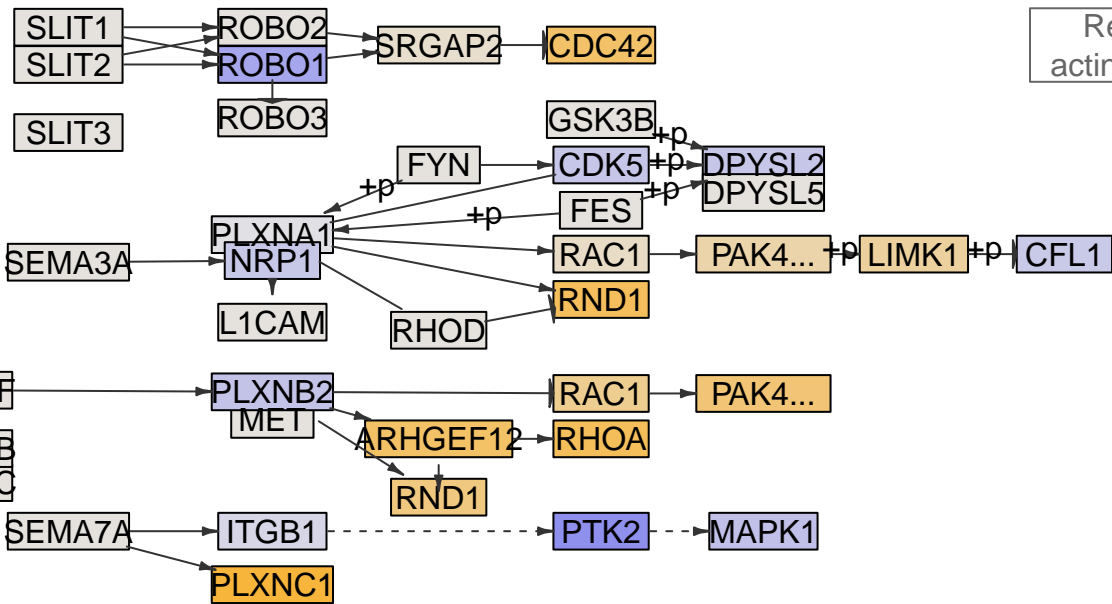

Regulation of actin cytoskeleton

Regulation of actin cytoskeleton

Axon guidance
MPI-179

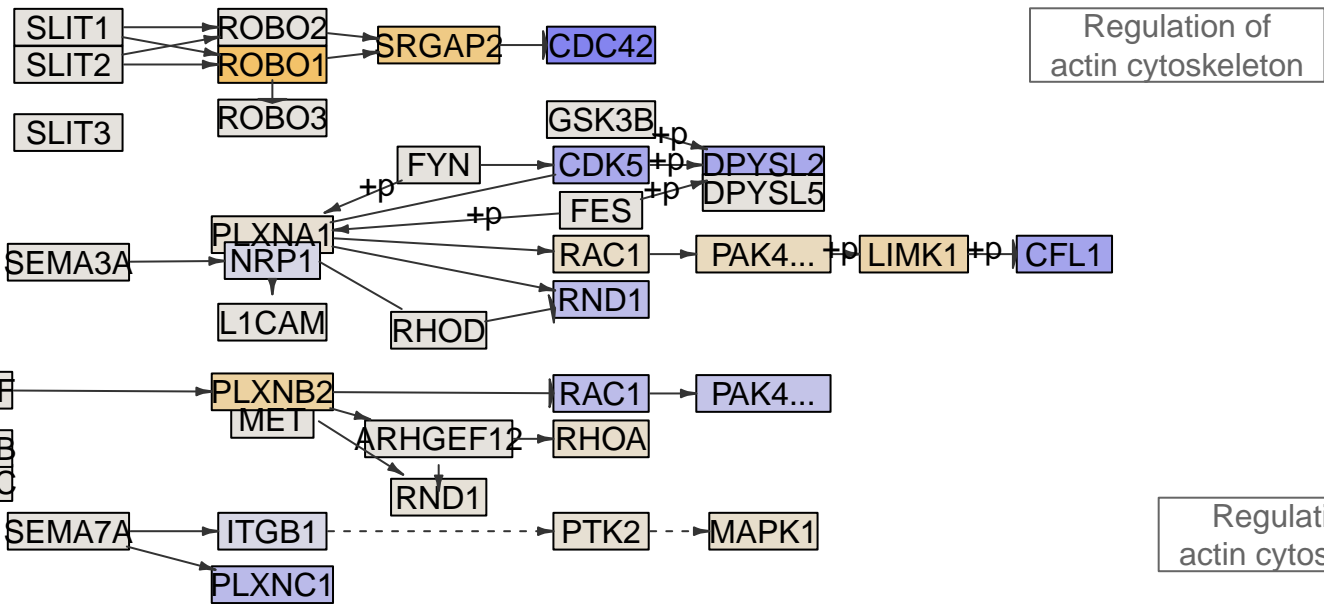
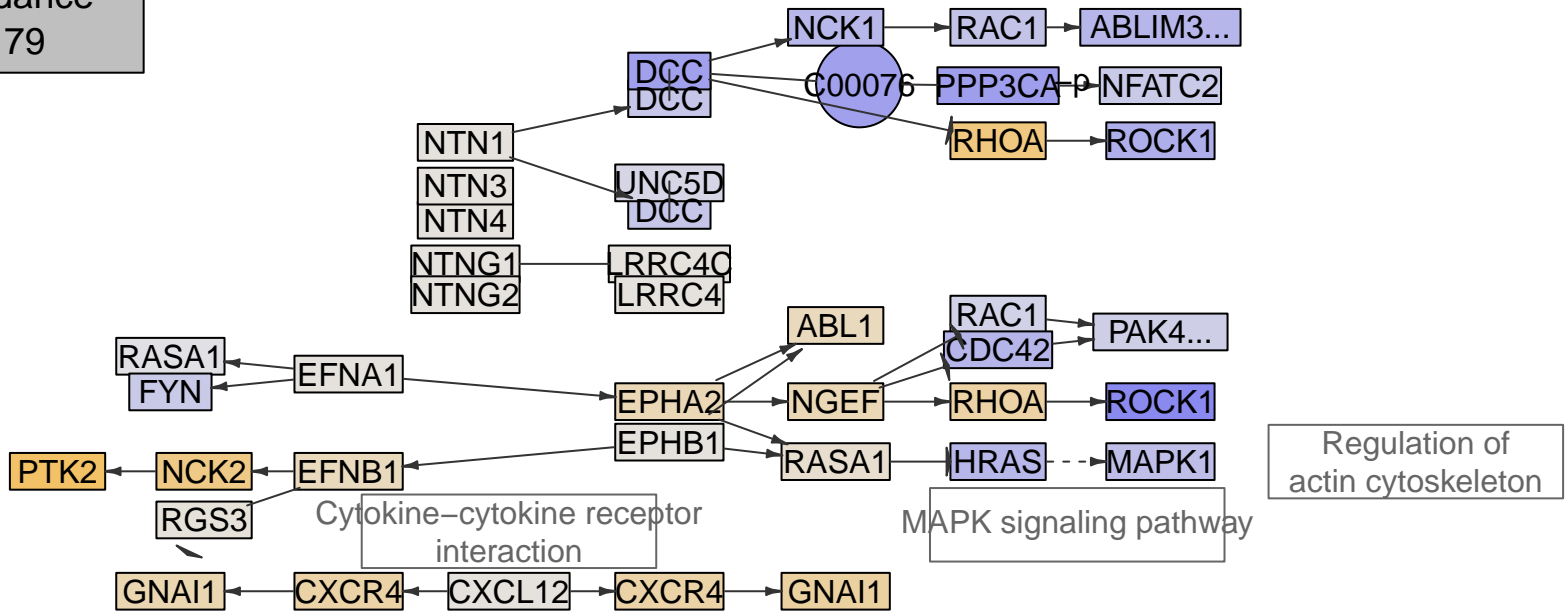

Regulation of actin cytoskeleton

Axon guidance
MPI-180

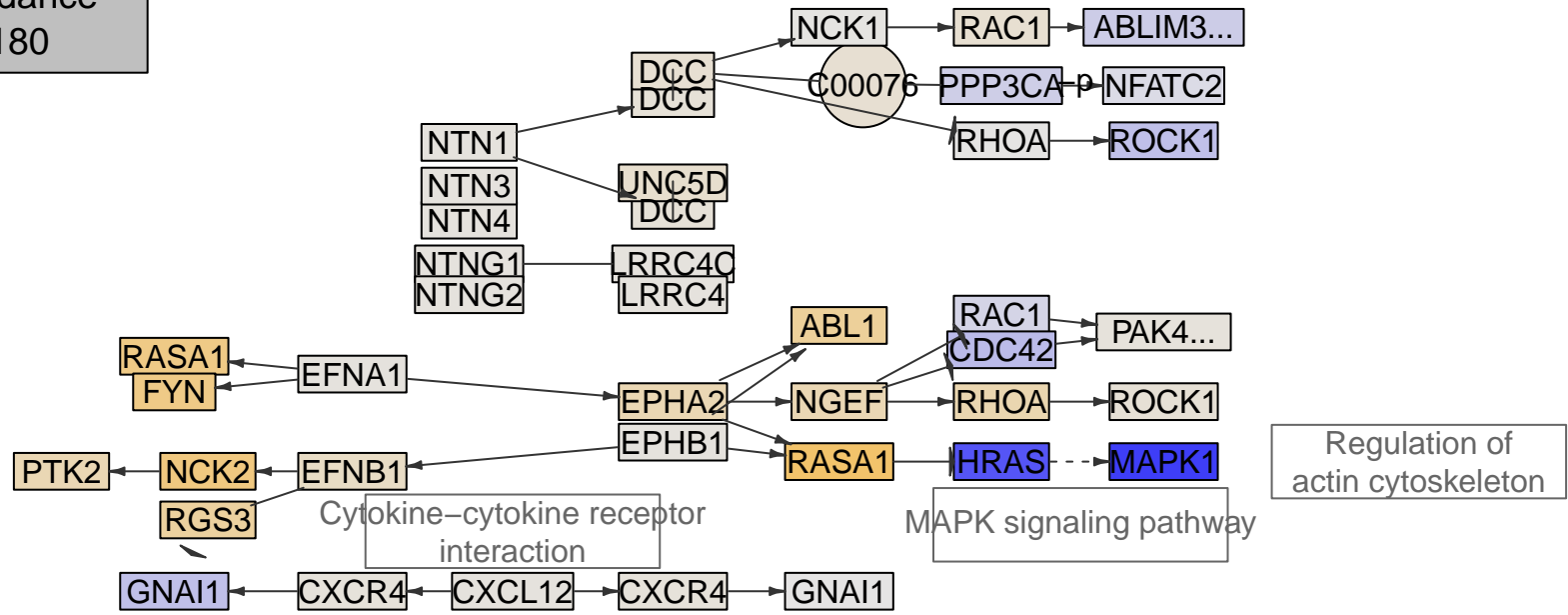

Regulation of actin cytoskeleton

MAPK signaling pathway

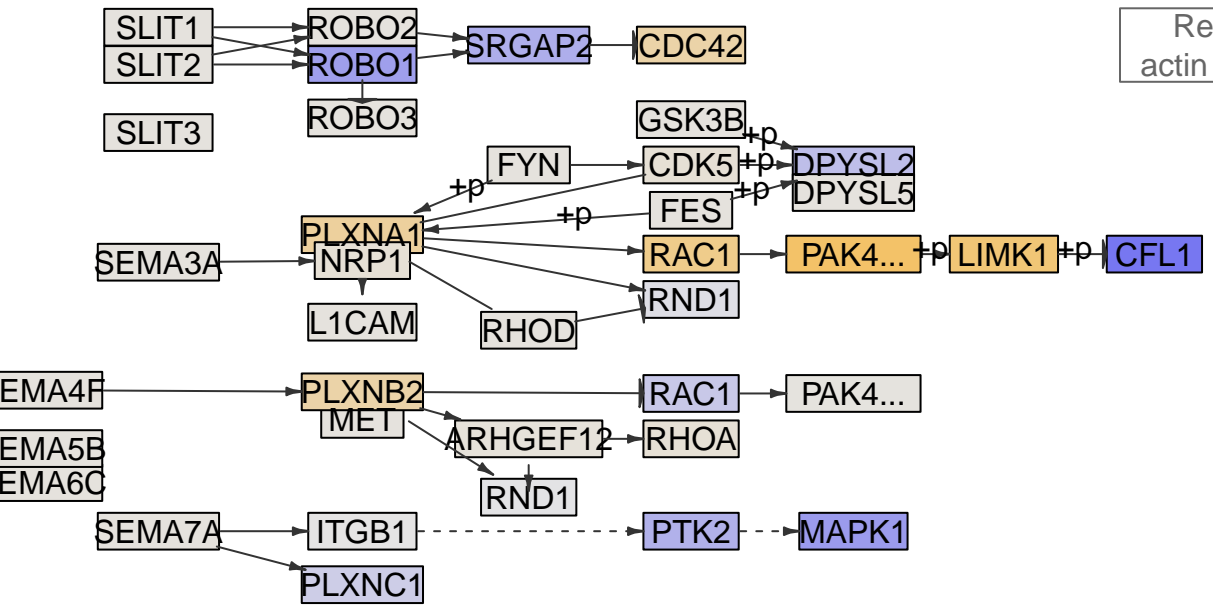

Regulation of actin cytoskeleton

Regulation of actin cytoskeleton

Axon guidance
MPI-182

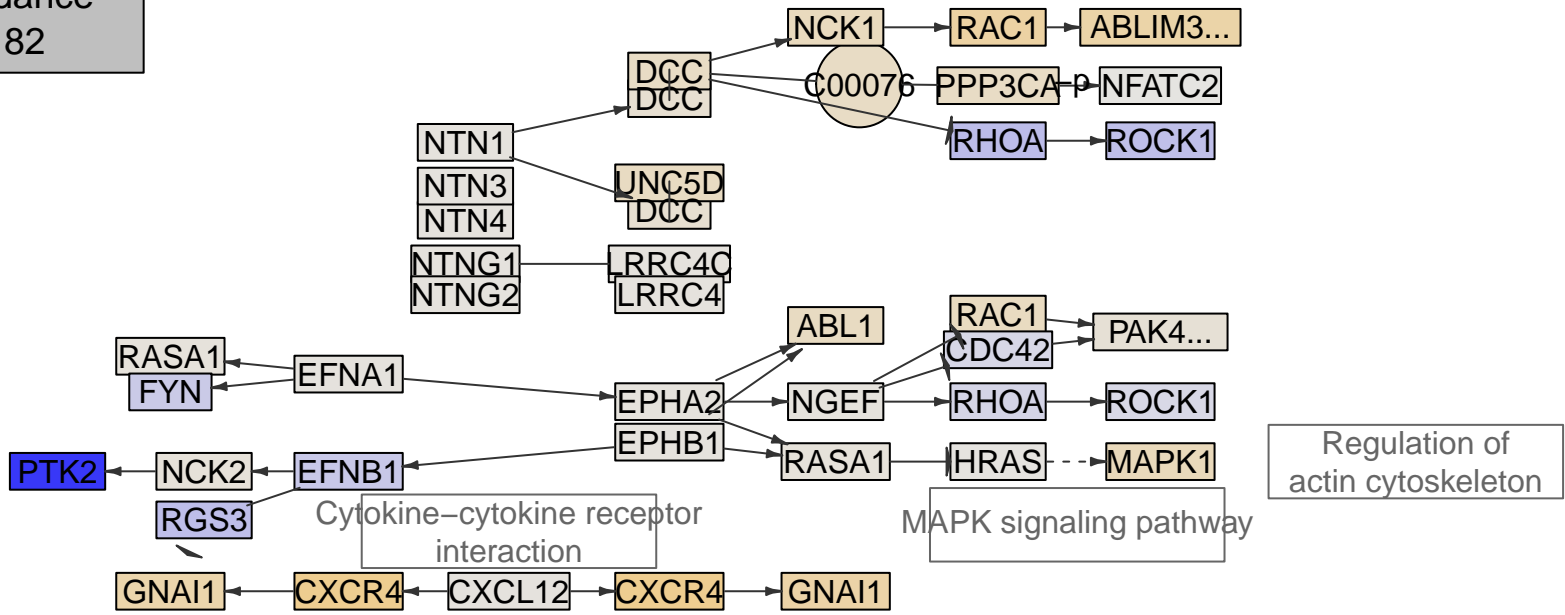

Regulation of actin cytoskeleton

MAPK signaling pathway

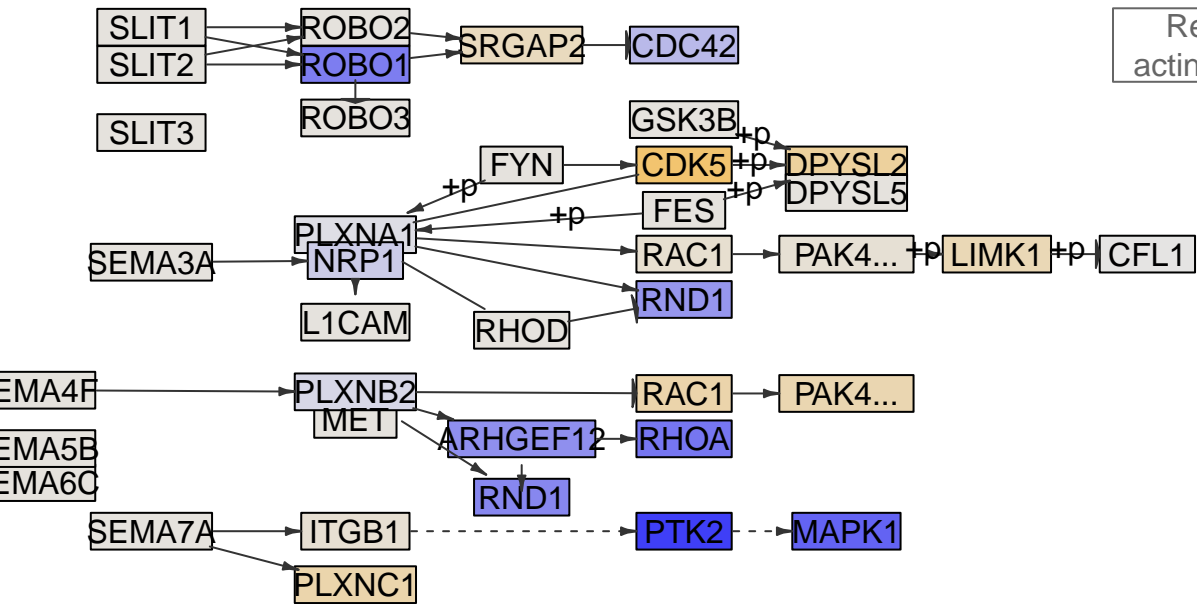

Regulation of actin cytoskeleton

Regulation of actin cytoskeleton

Axon guidance
MPI-183

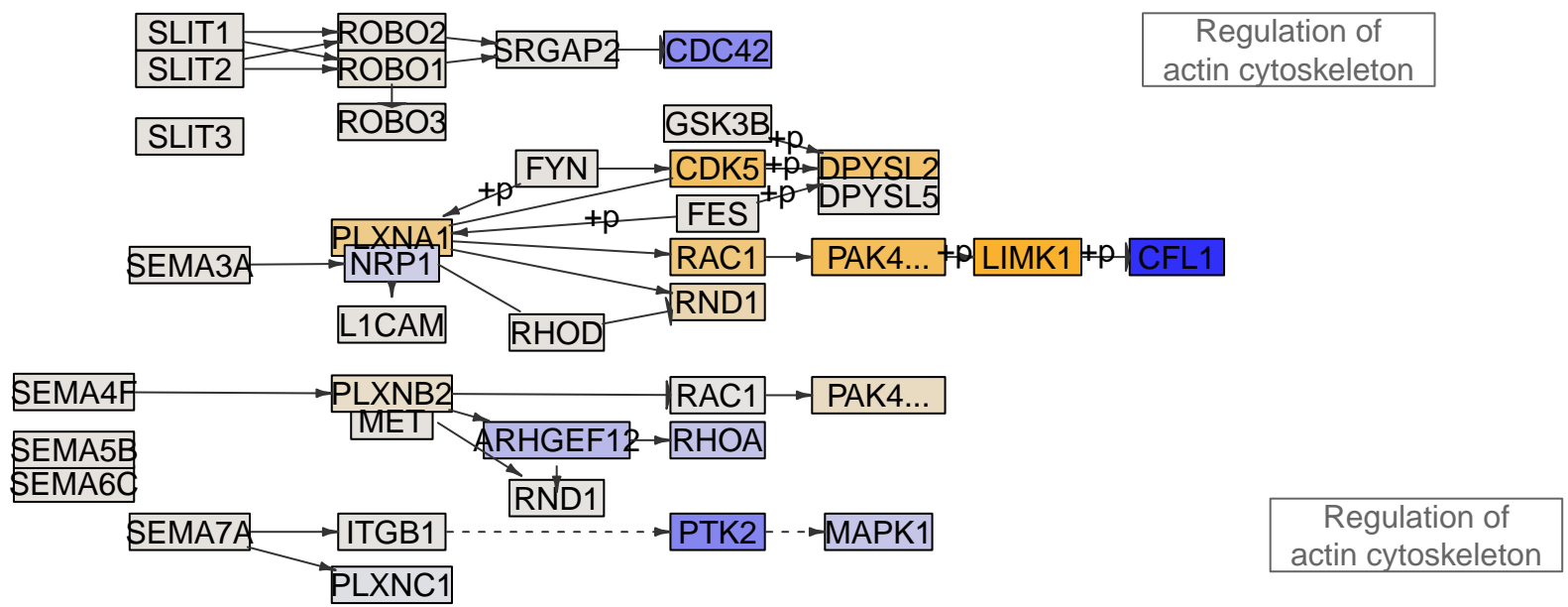
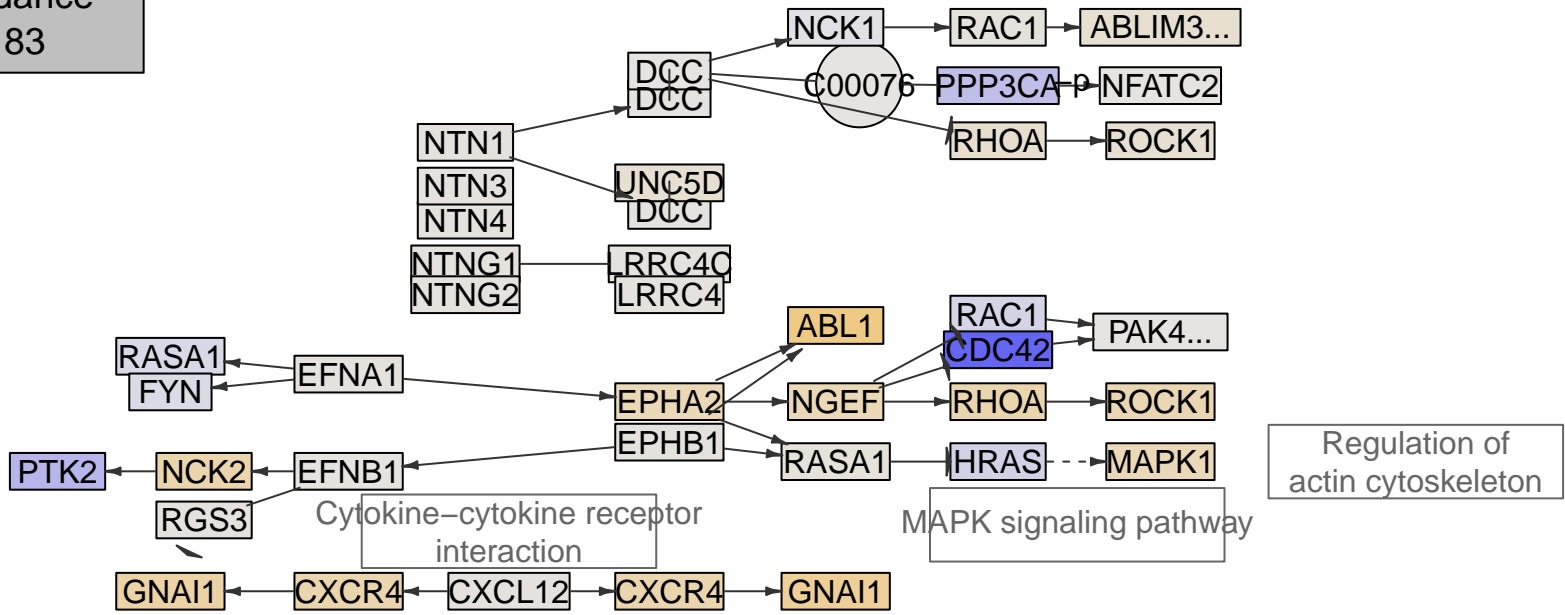

Axon guidance
MPI-184

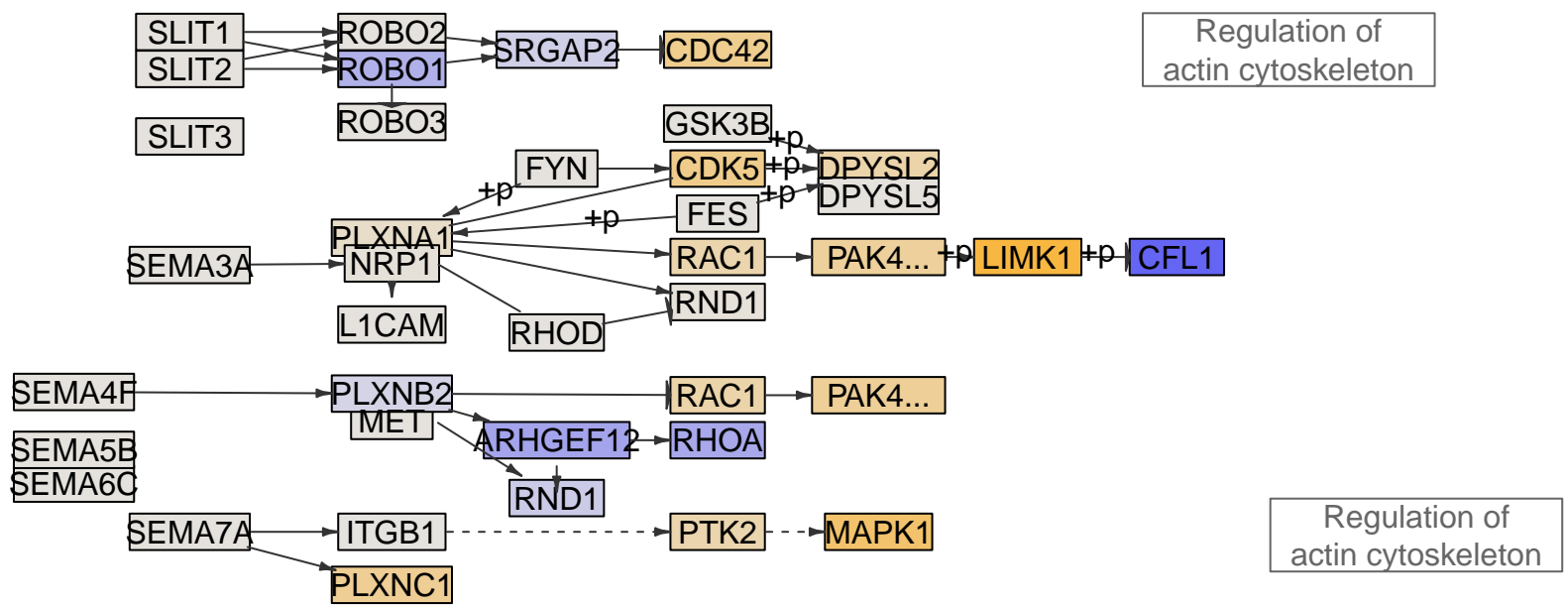
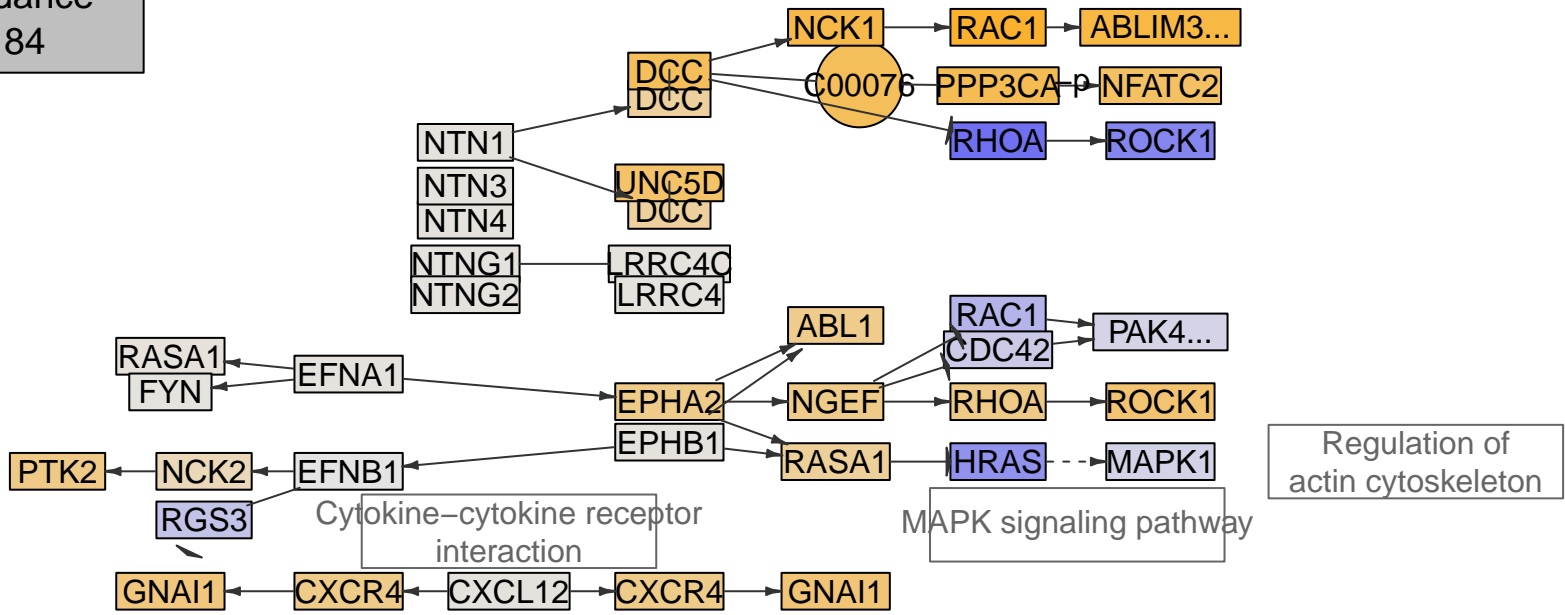

Axon guidance
MPI-185

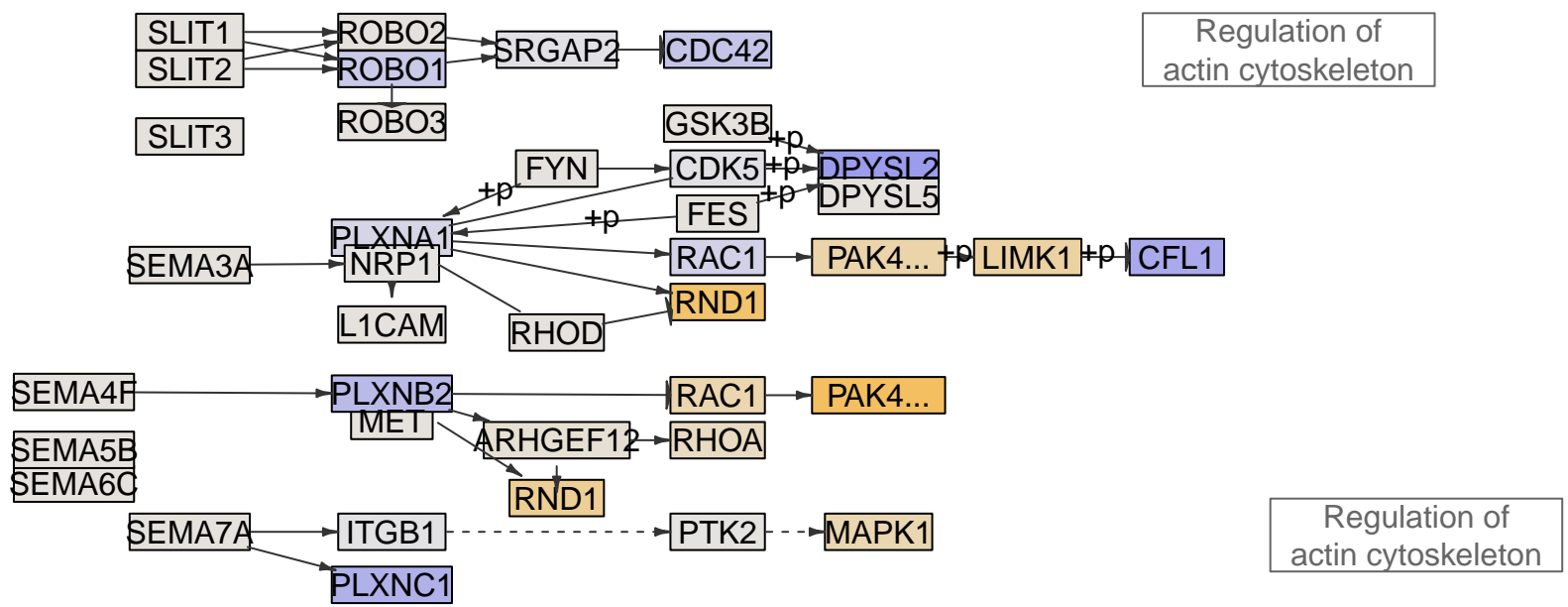
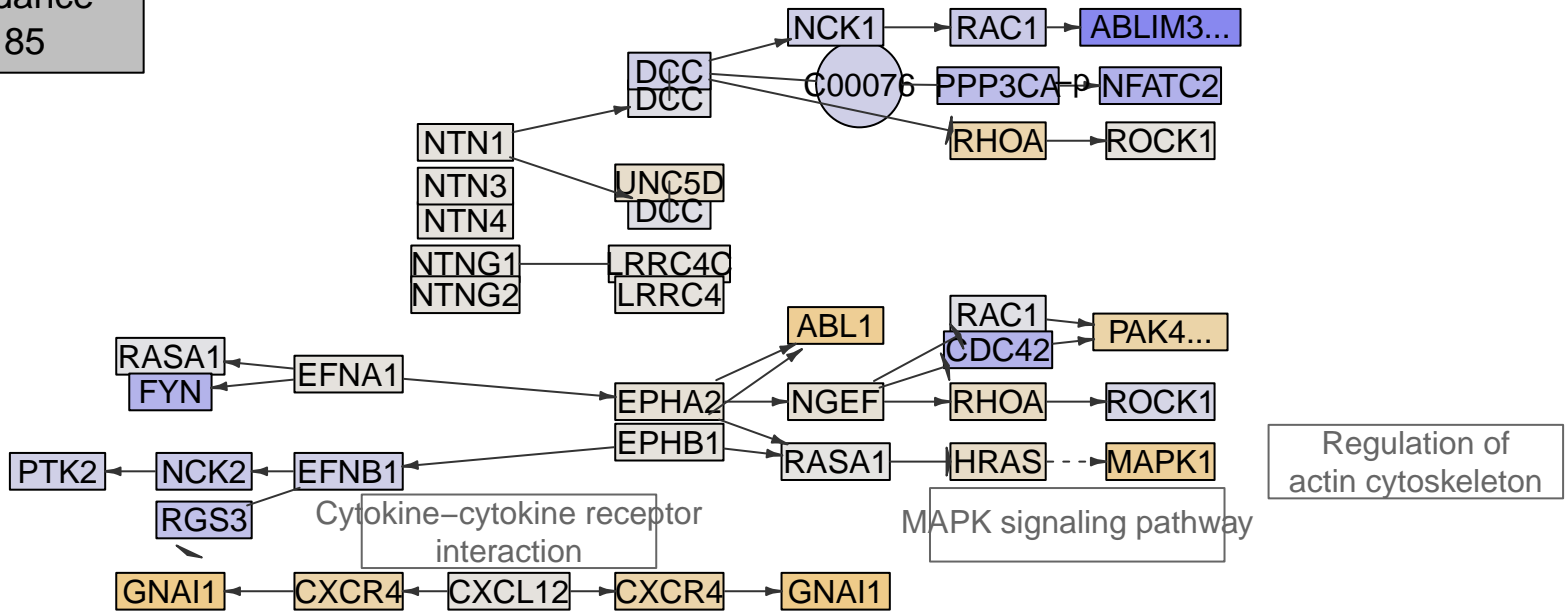

Axon guidance
MPI-186

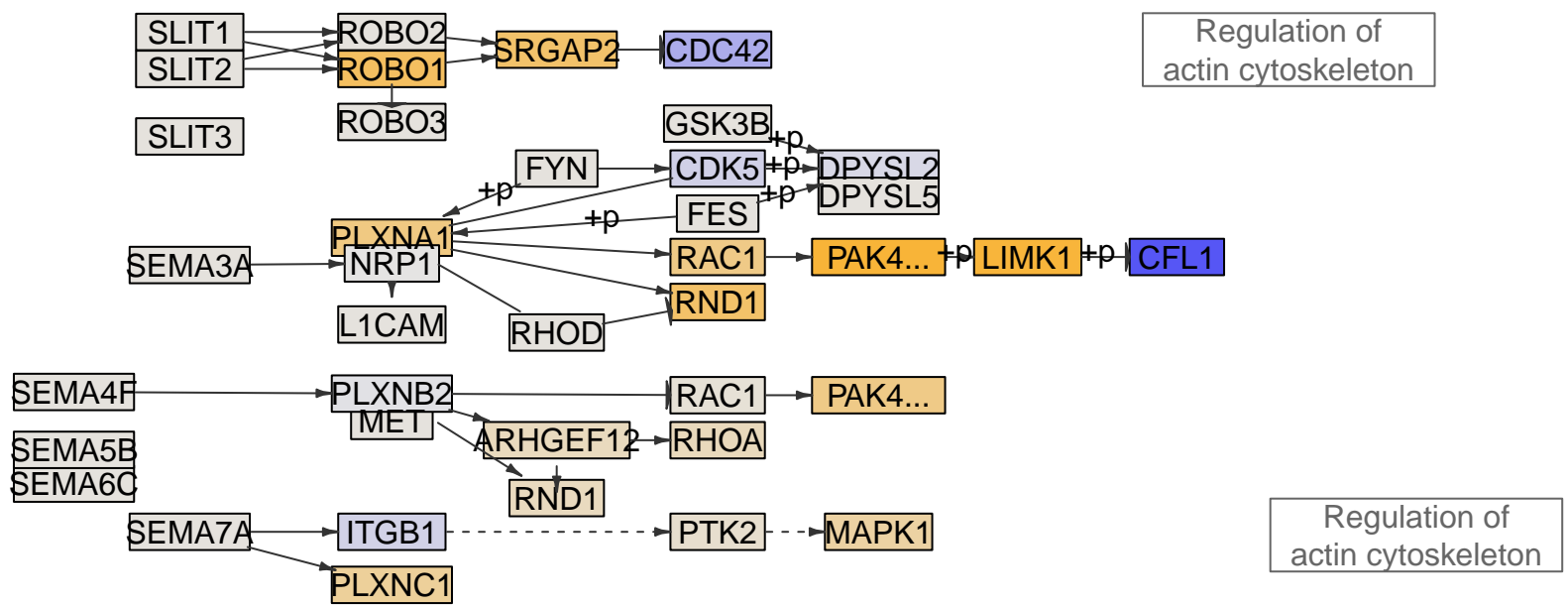
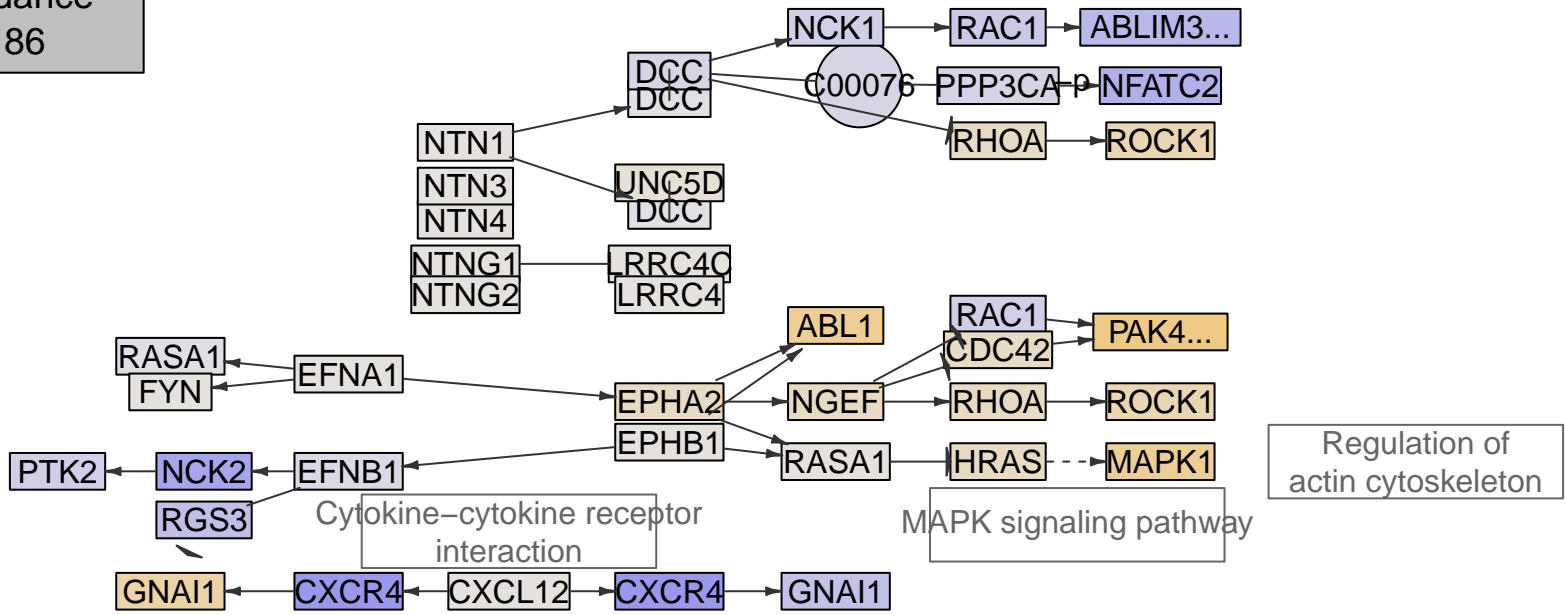

Axon guidance
MPI-188

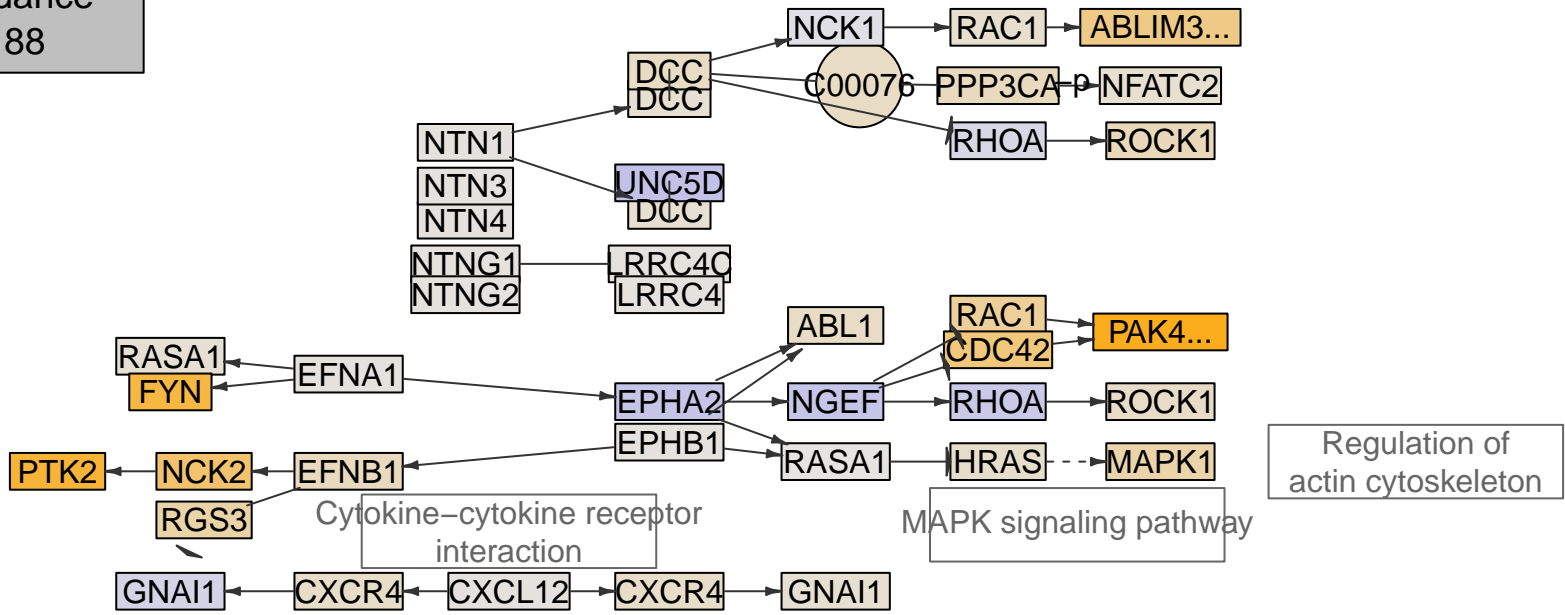

Regulation of actin cytoskeleton

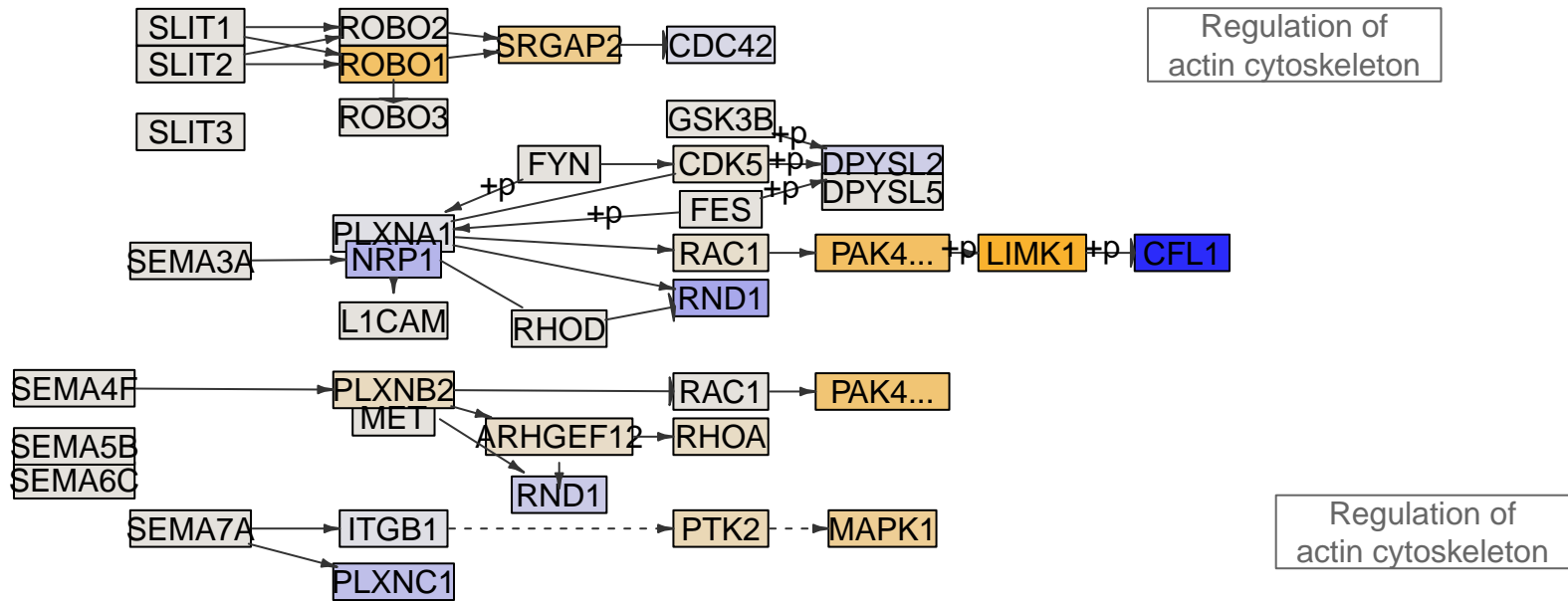

Regulation of actin cytoskeleton

Regulation of actin cytoskeleton

Axon guidance
MPI-189

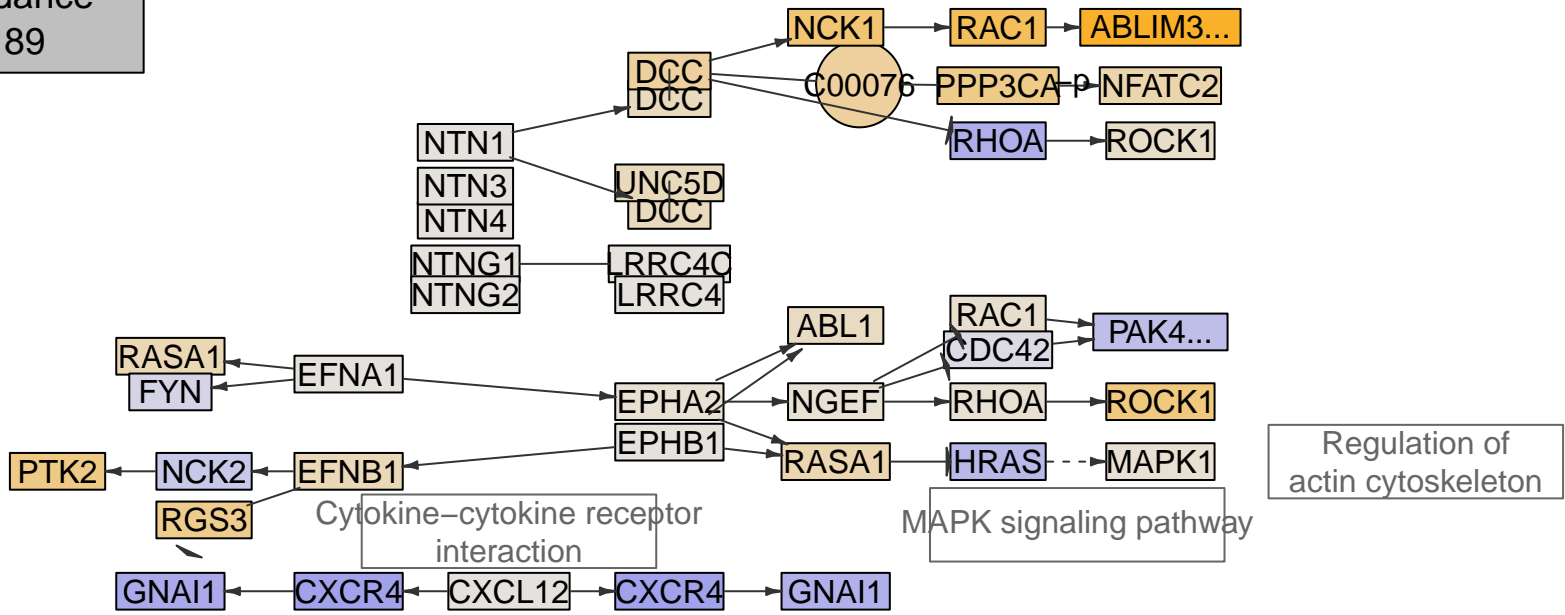

Regulation of actin cytoskeleton

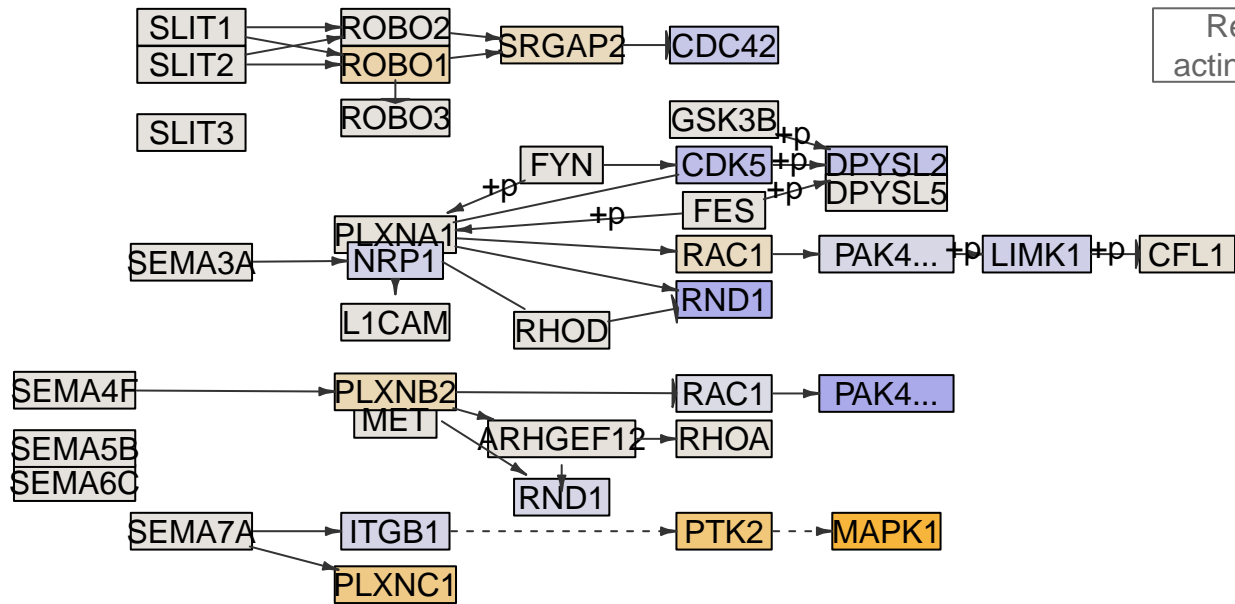

Regulation of actin cytoskeleton

Regulation of actin cytoskeleton

Axon guidance
MPI-190

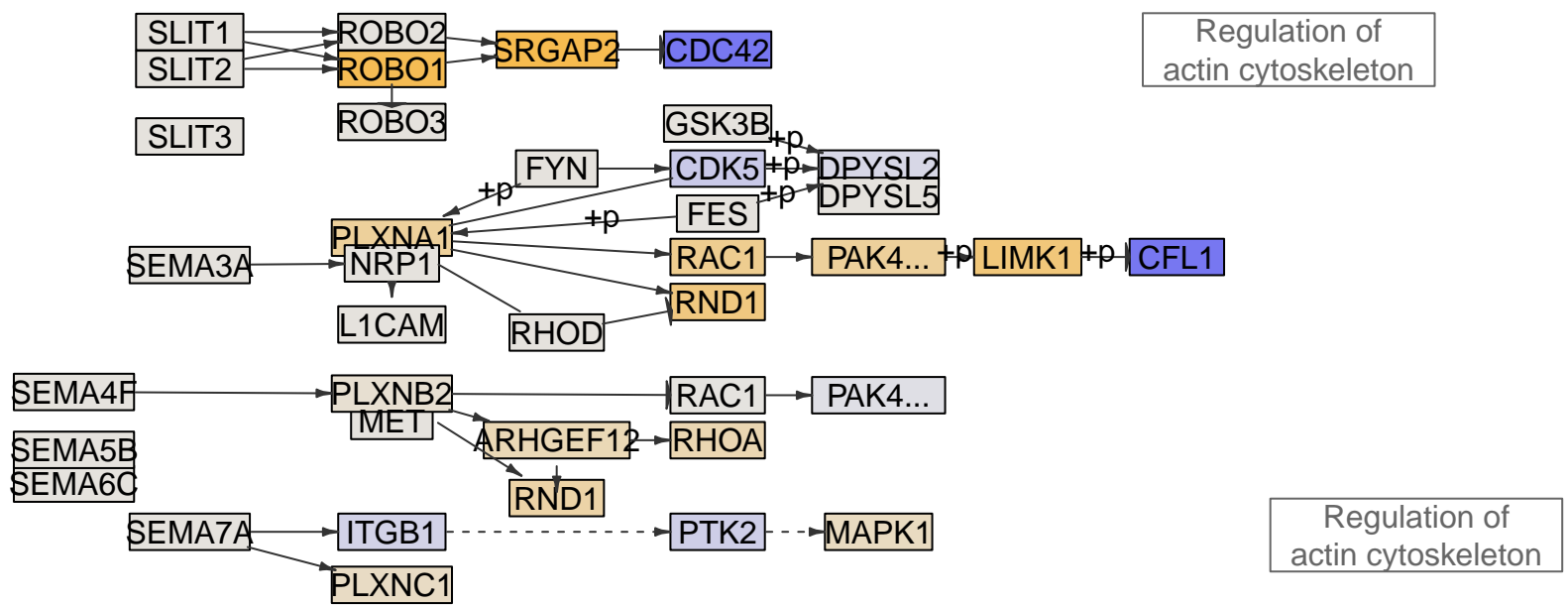
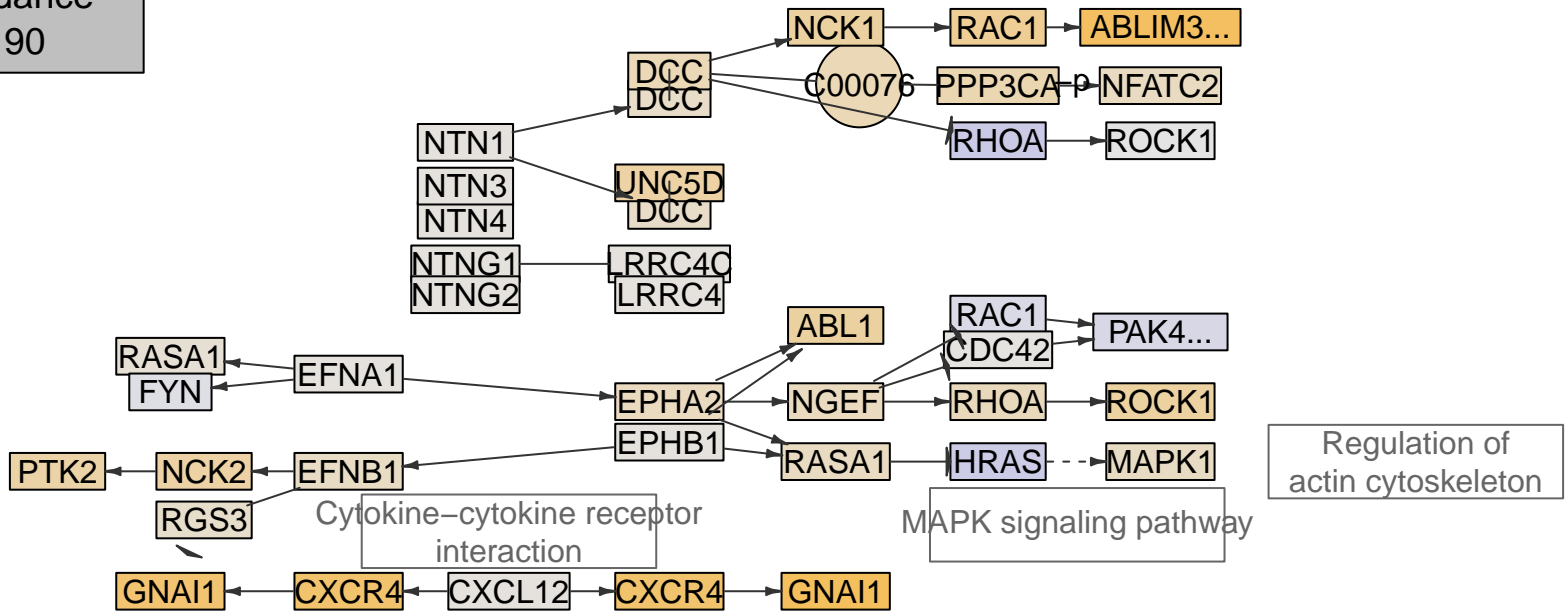

Axon guidance
MPI-191

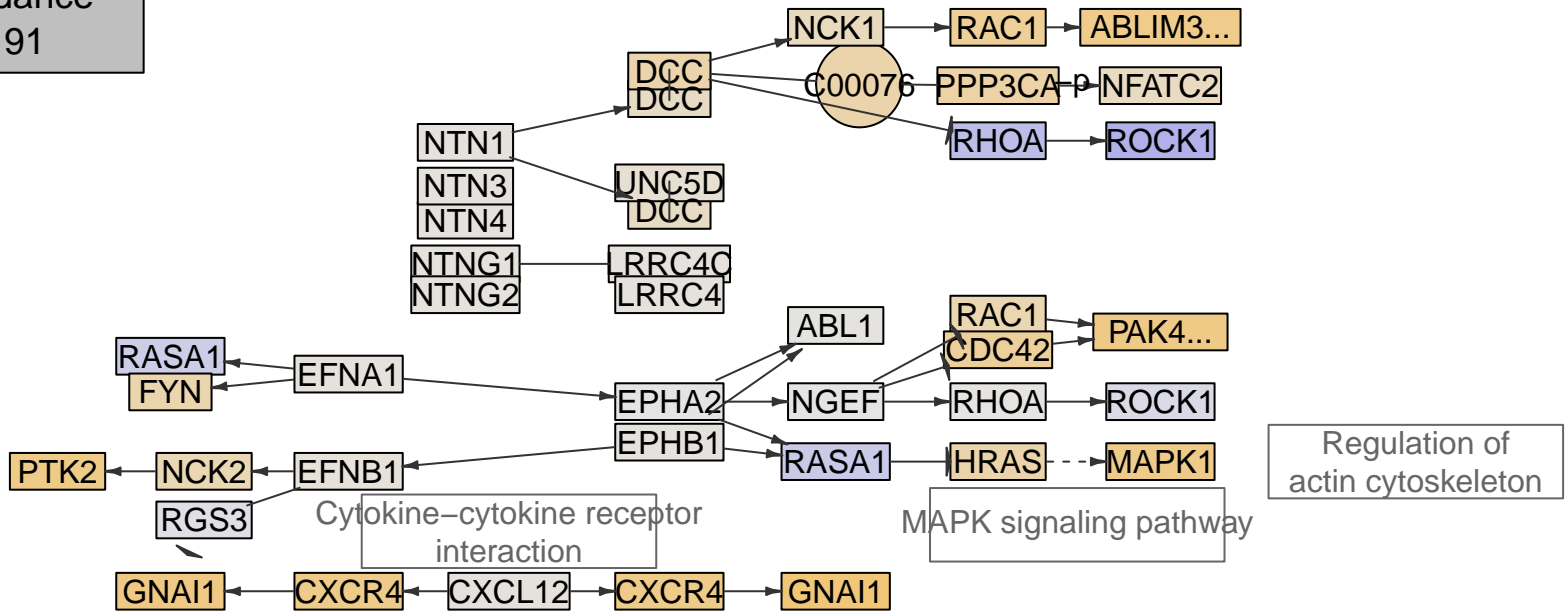

Regulation of actin cytoskeleton

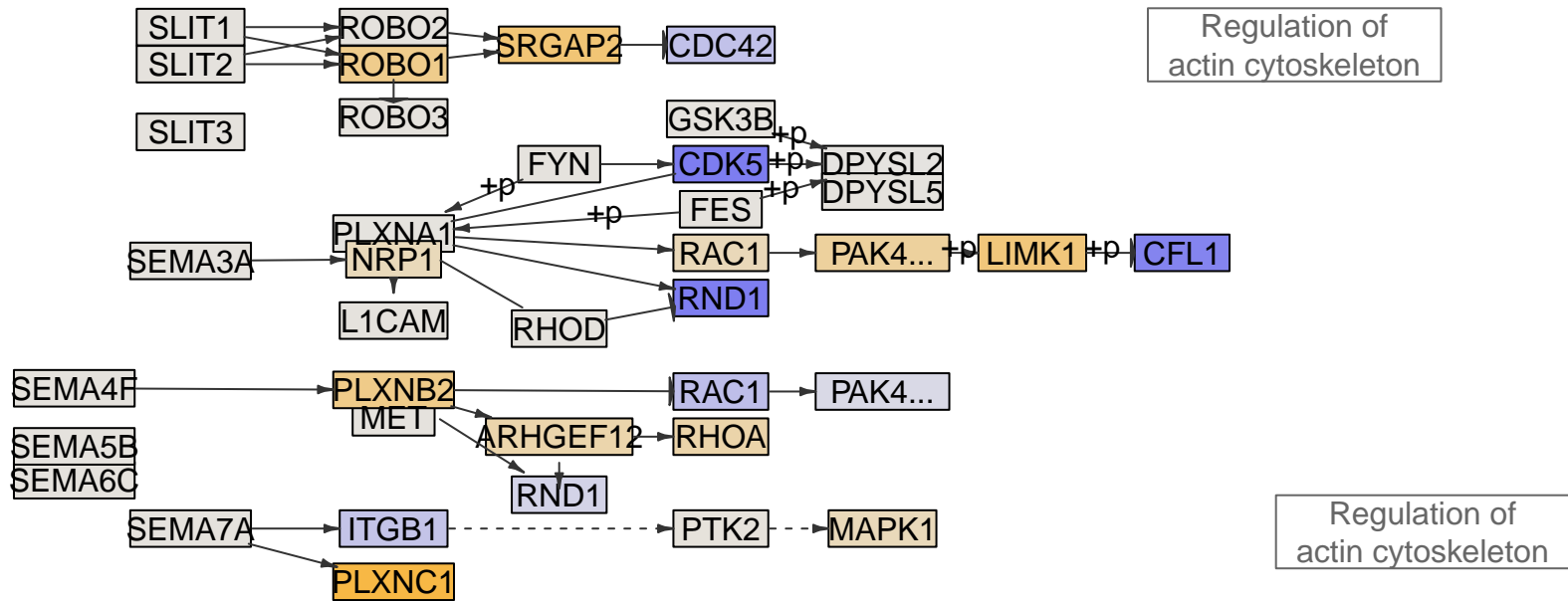

Regulation of actin cytoskeleton

Regulation of actin cytoskeleton

Axon guidance
MPI-192

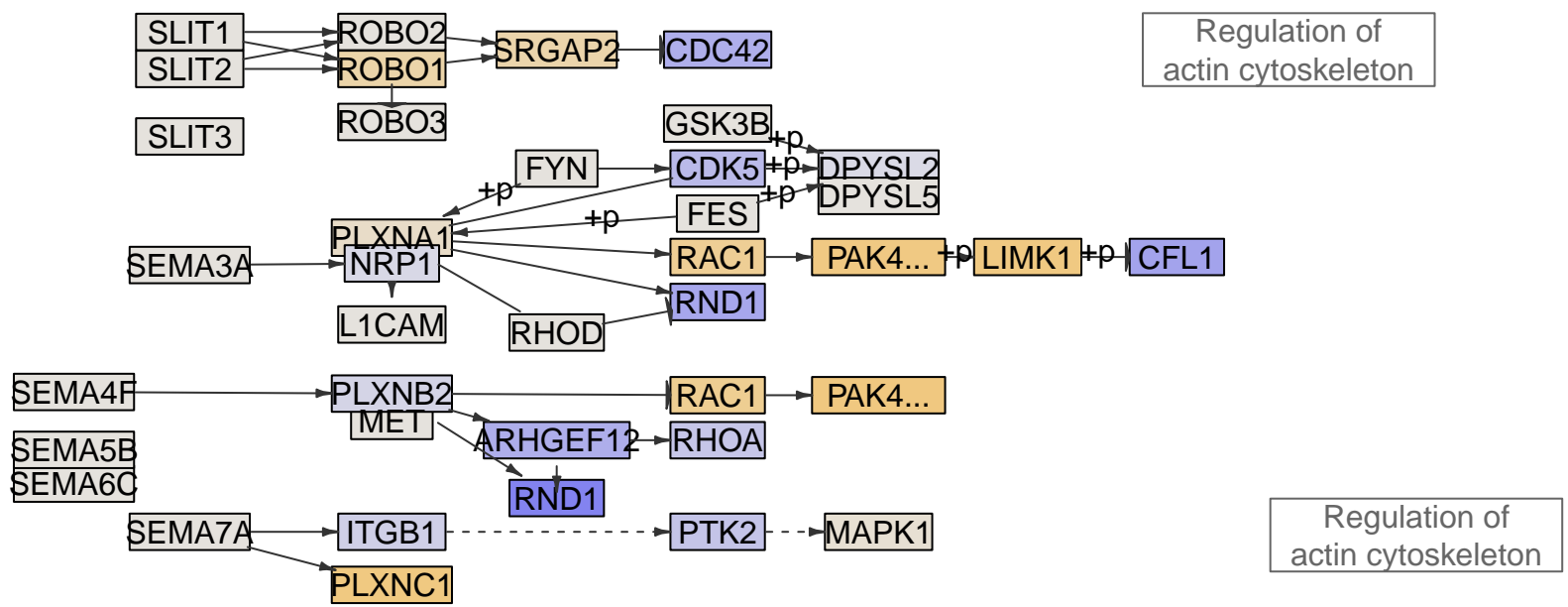
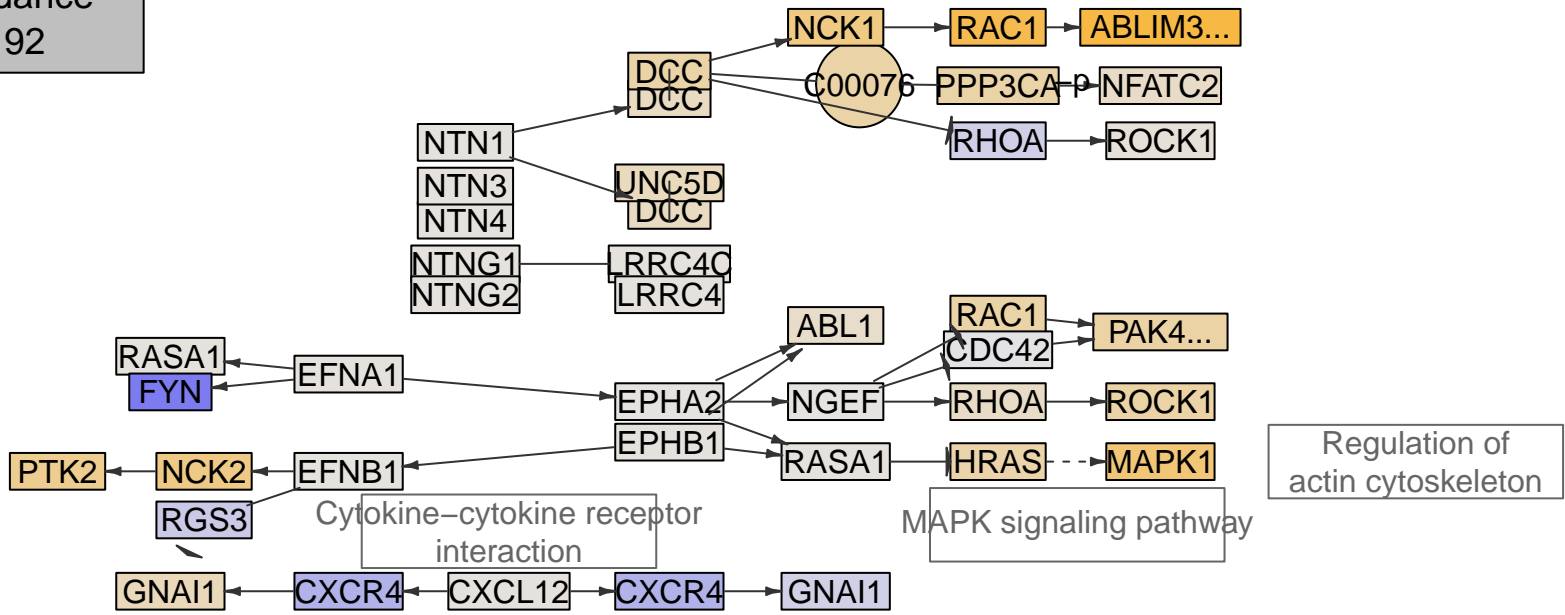

Axon guidance
MPI-194

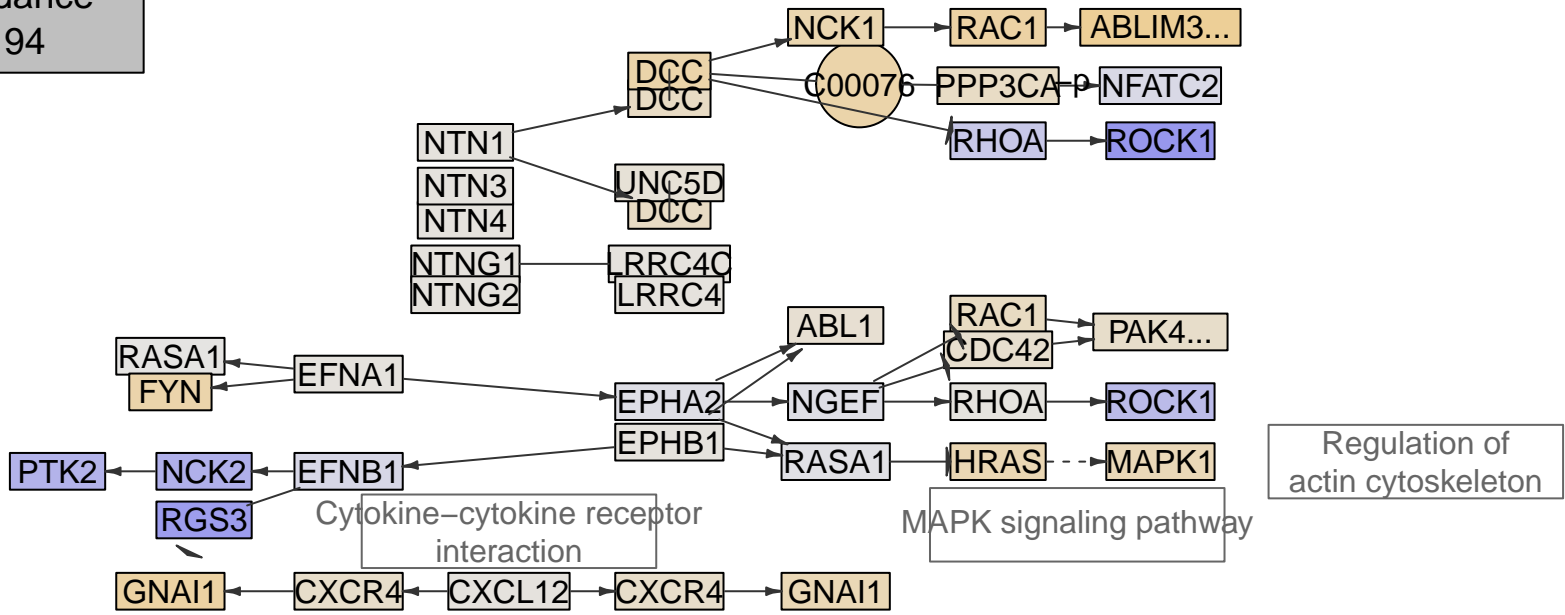

Regulation of actin cytoskeleton

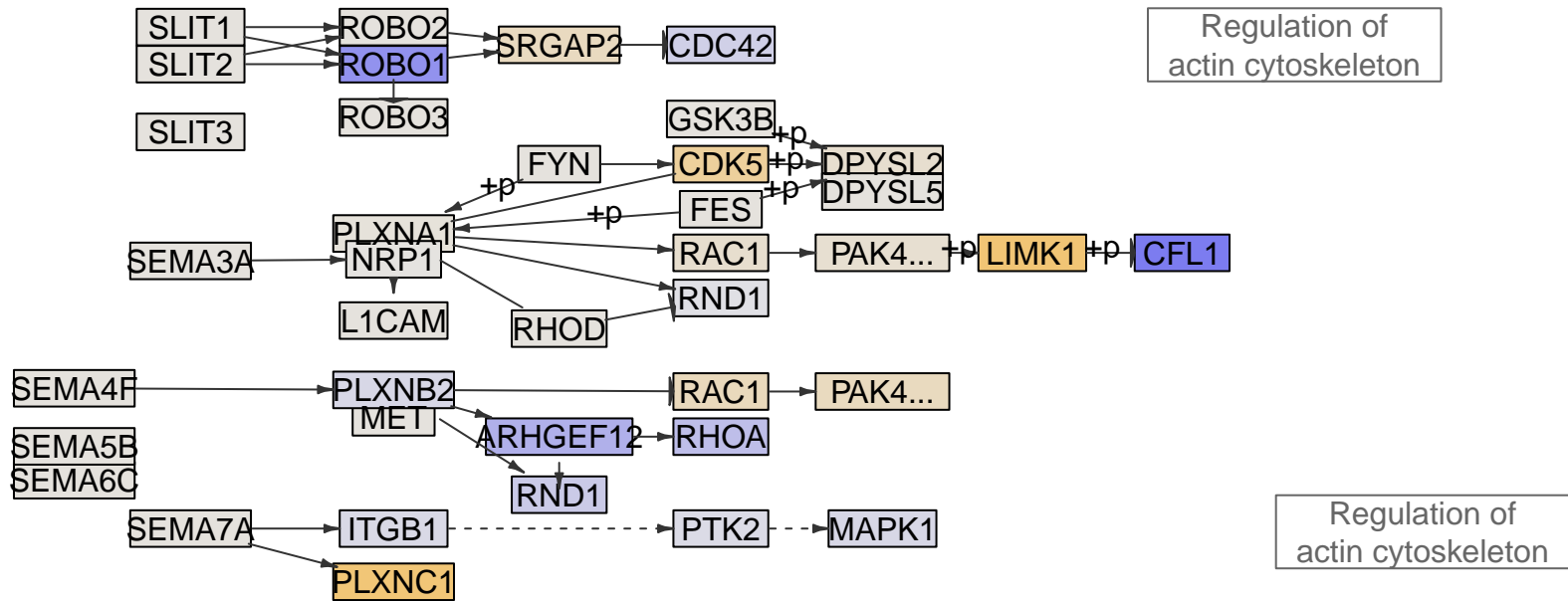

Regulation of actin cytoskeleton

Regulation of actin cytoskeleton

Axon guidance
MPI-195

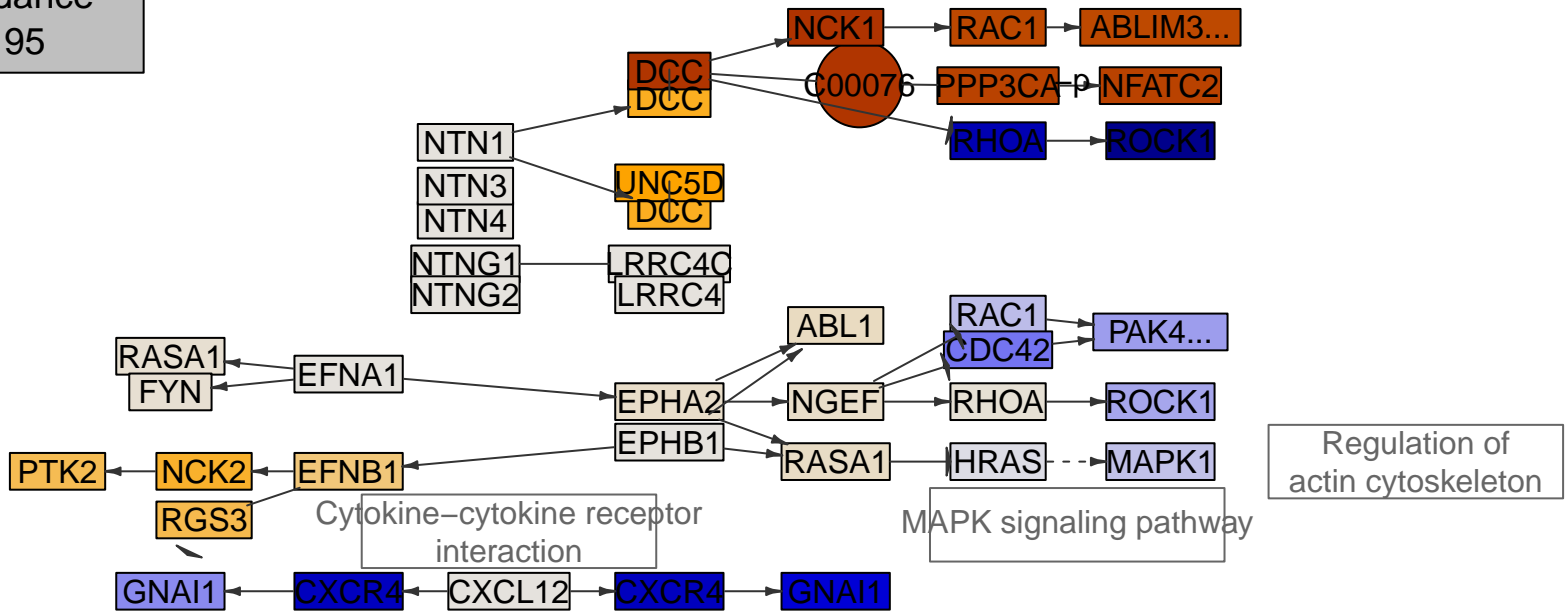

Regulation of actin cytoskeleton

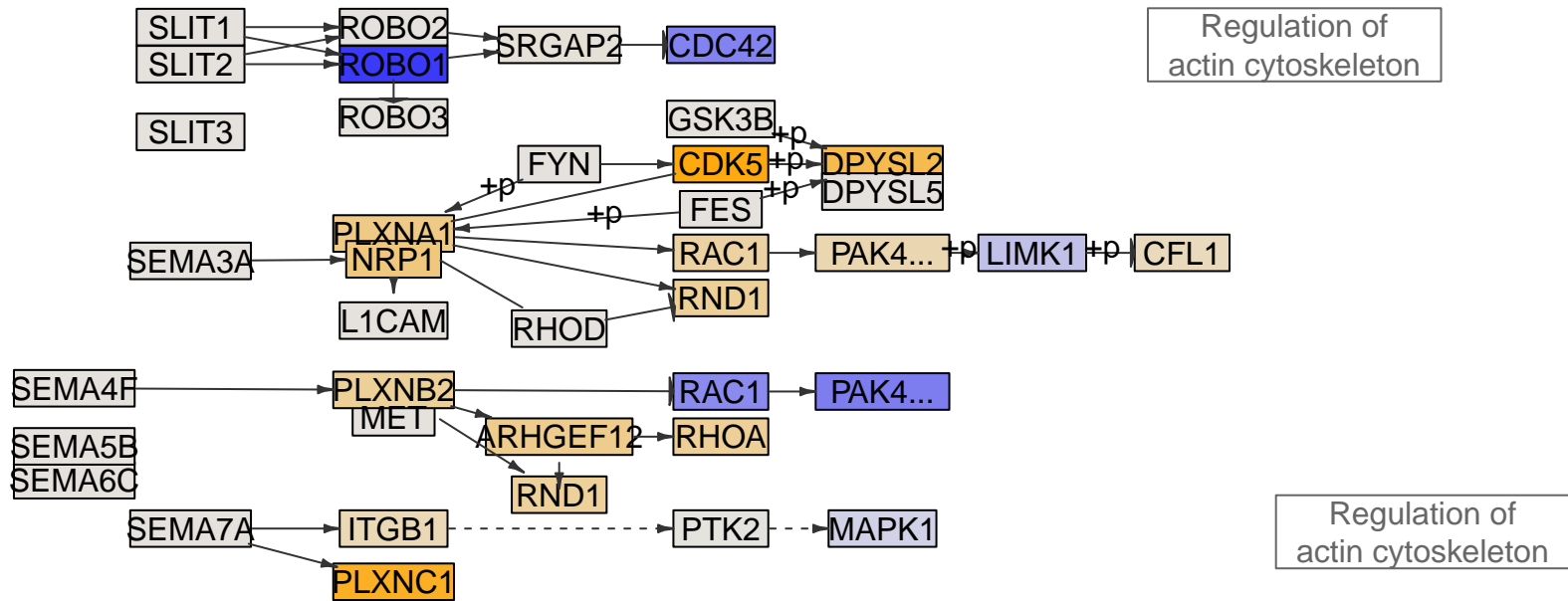

Regulation of actin cytoskeleton

Regulation of actin cytoskeleton

Axon guidance
MPI-196

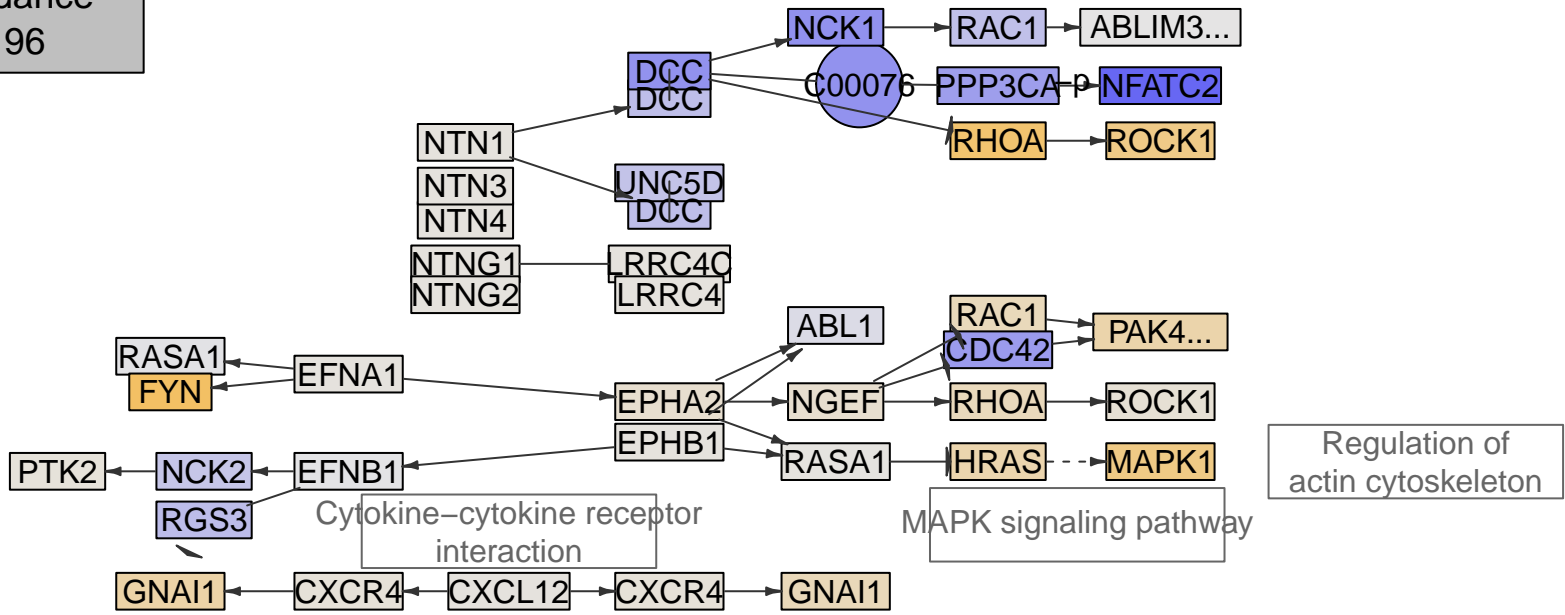

Regulation of actin cytoskeleton

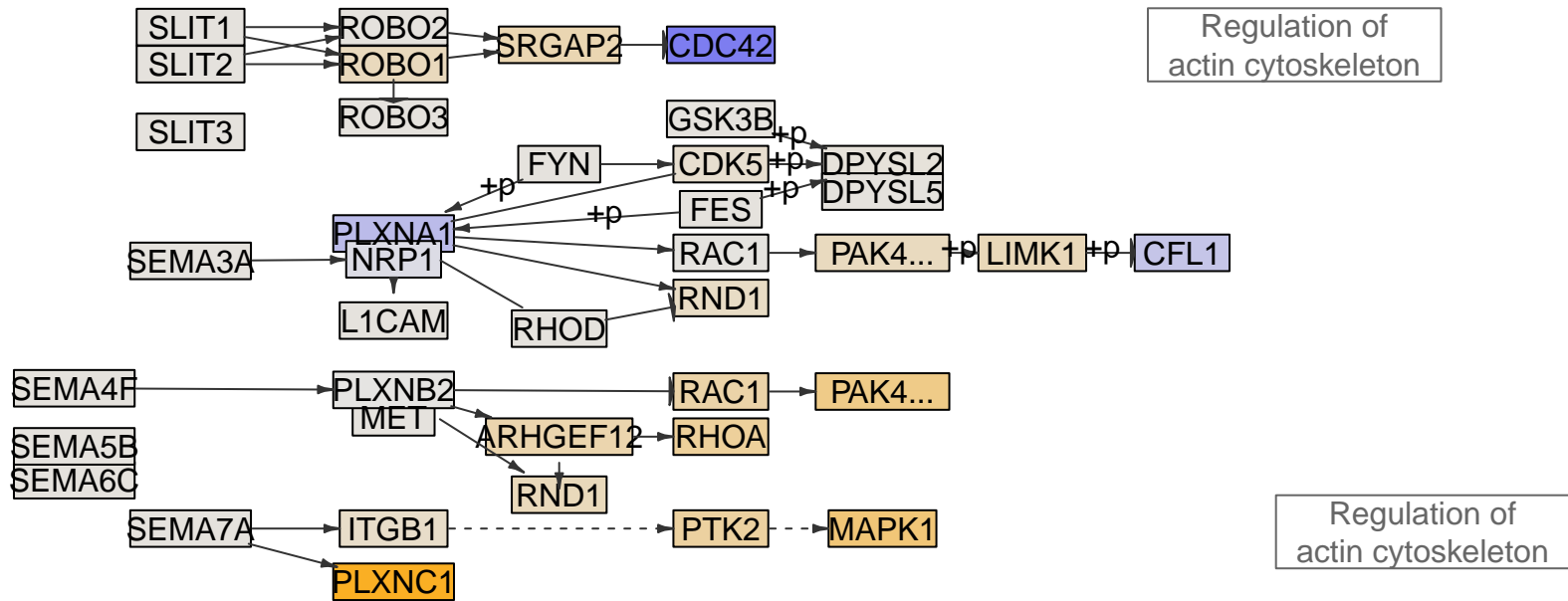

Regulation of actin cytoskeleton

Regulation of actin cytoskeleton

Axon guidance
MPI-198

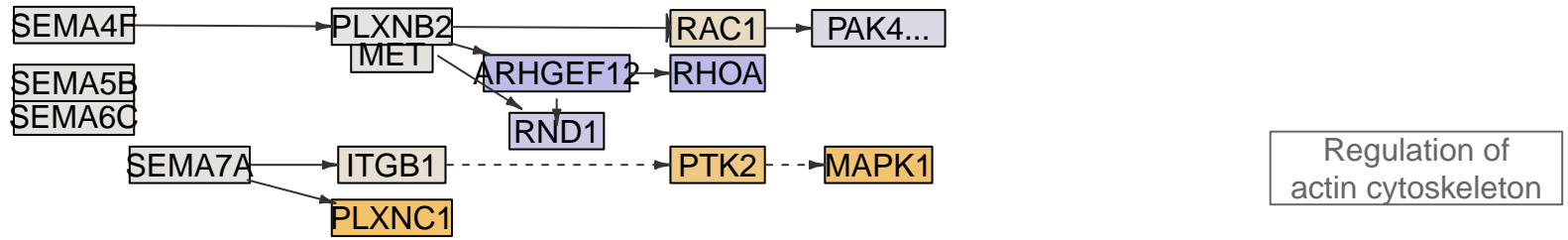
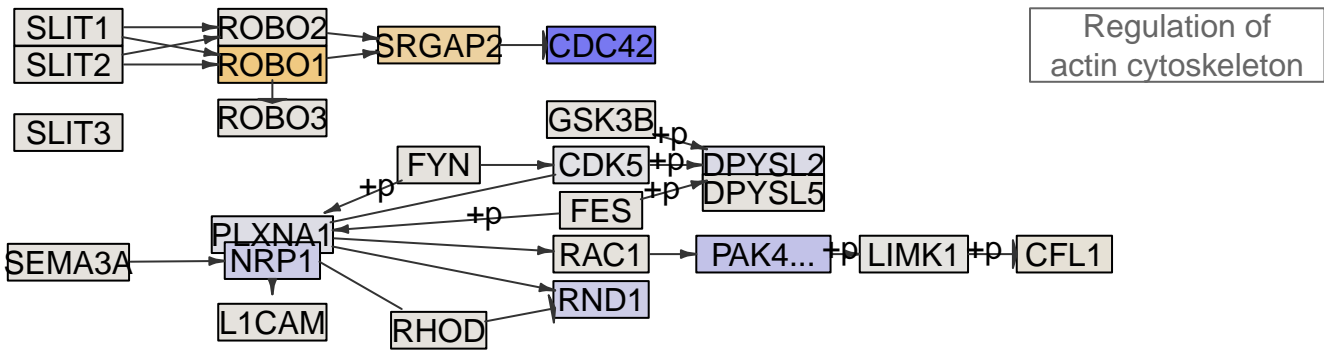
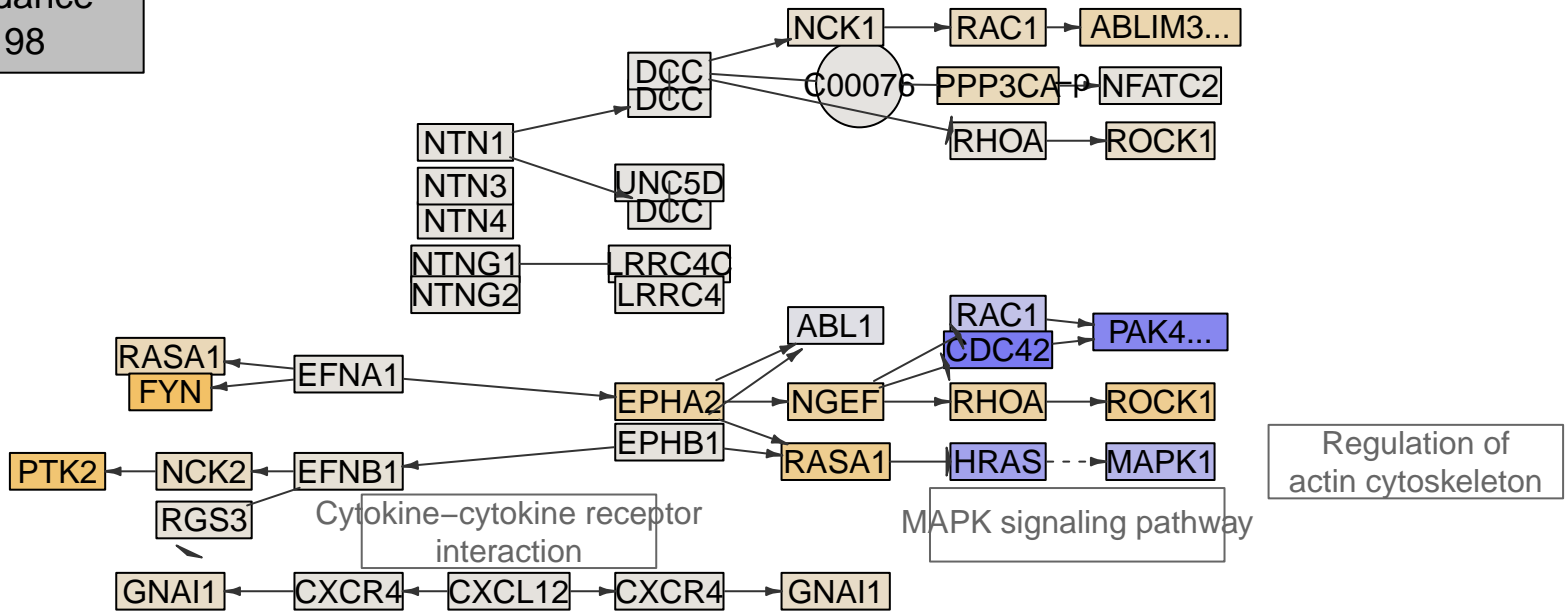

Regulation of actin cytoskeleton

Axon guidance
MPI-199

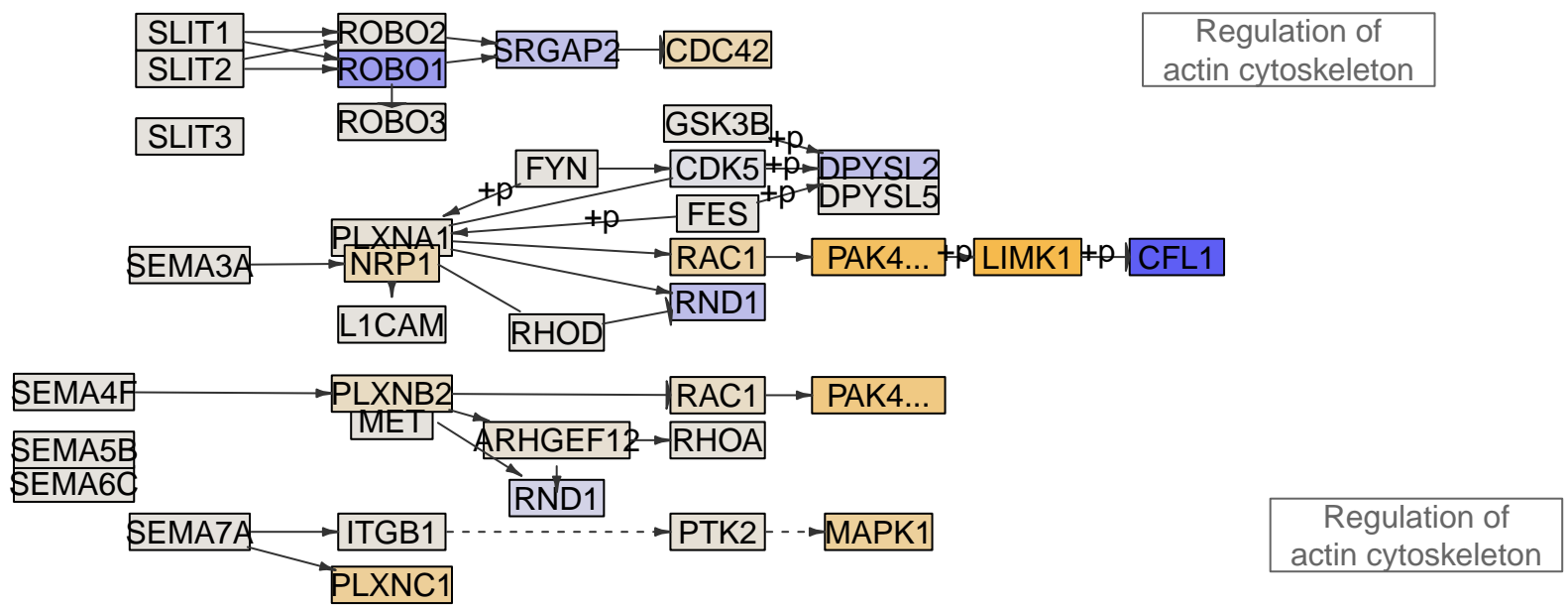
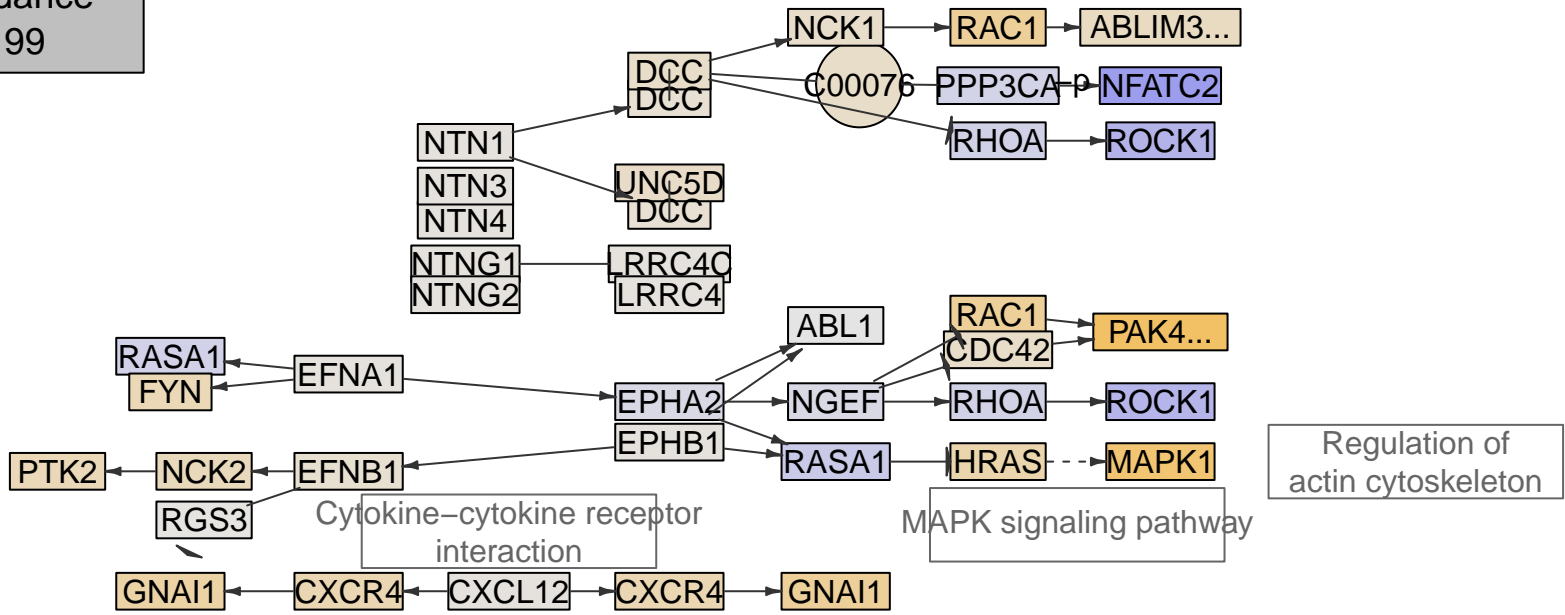

Axon guidance
MPI-200

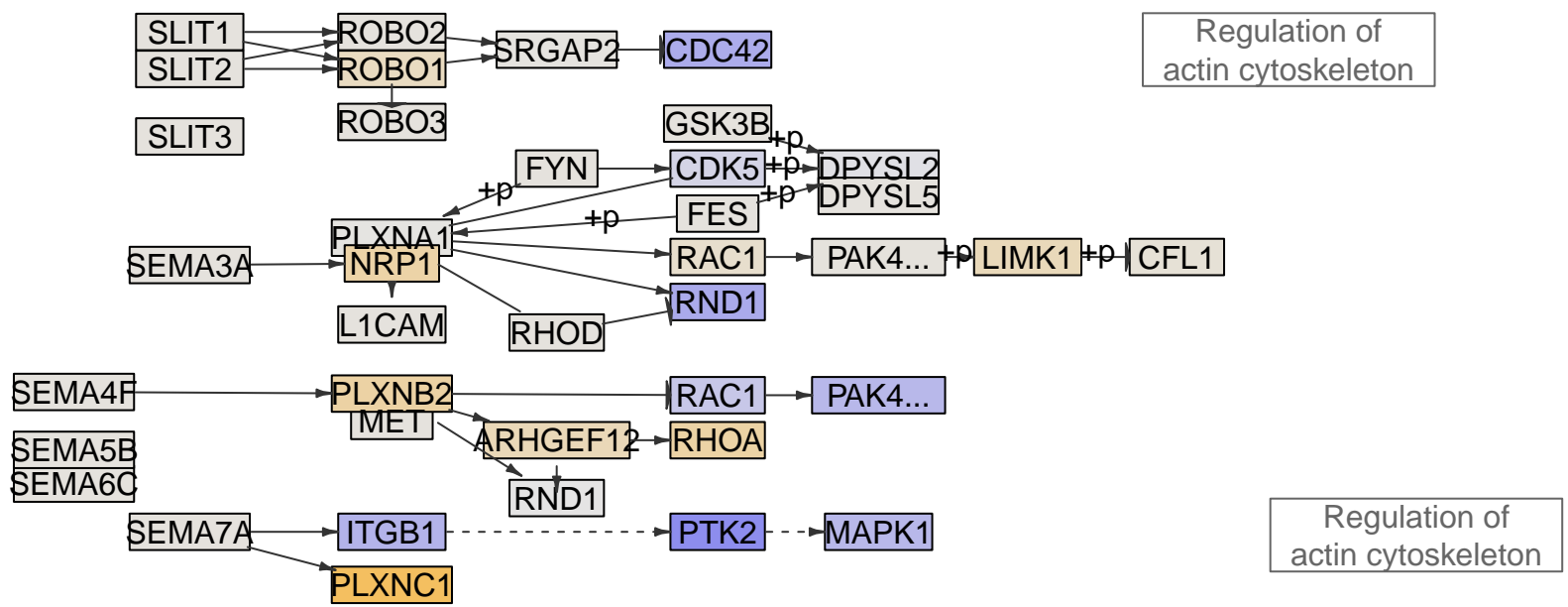
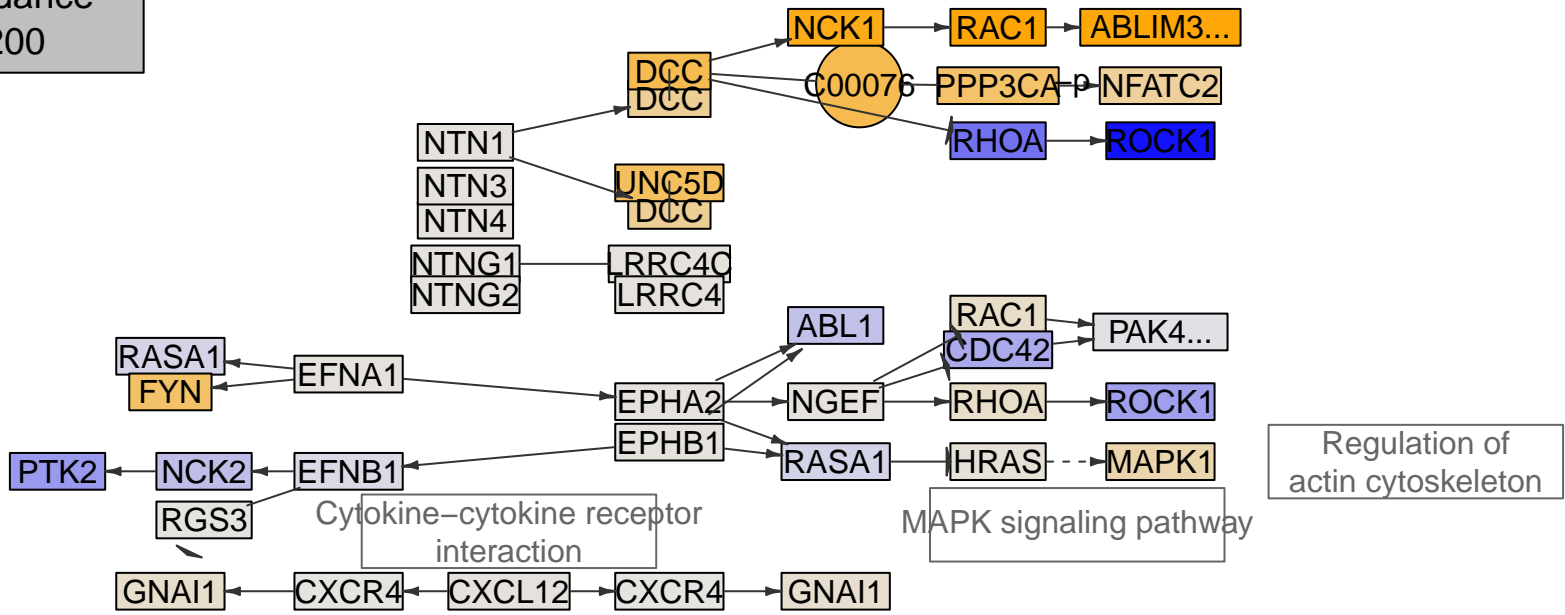

Axon guidance
MPI-201

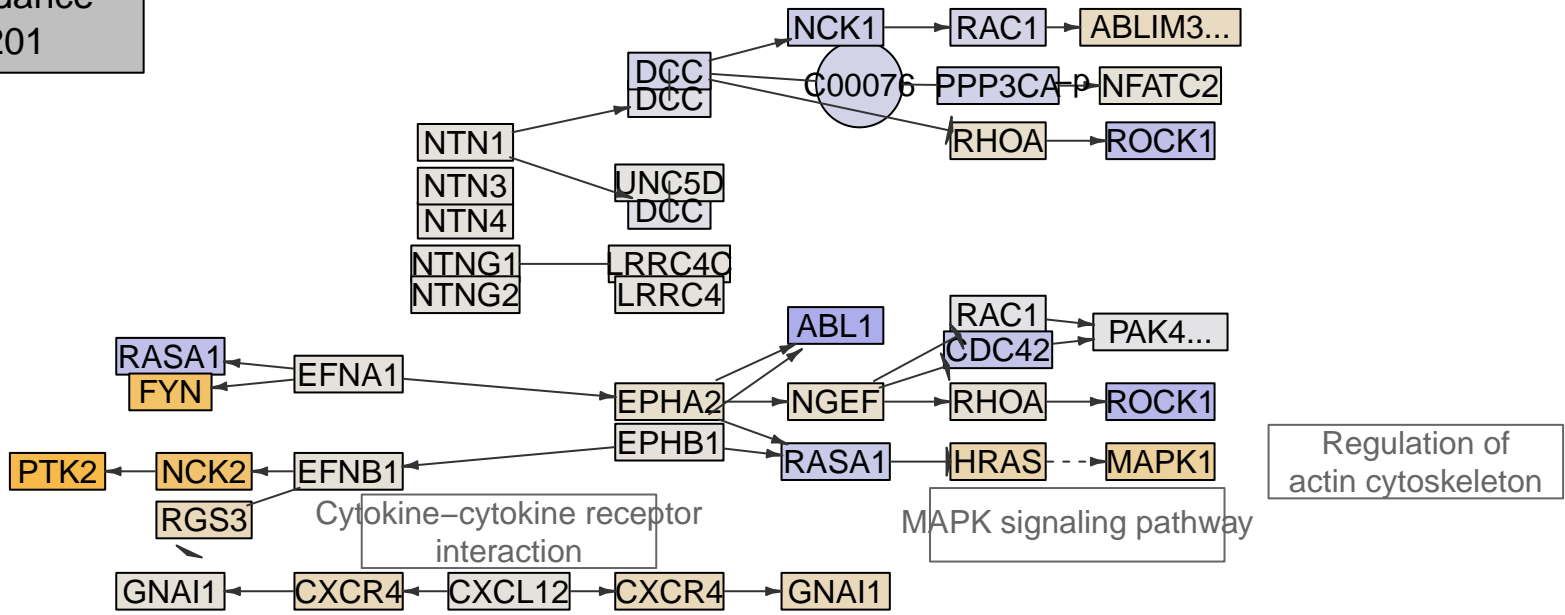

Regulation of actin cytoskeleton

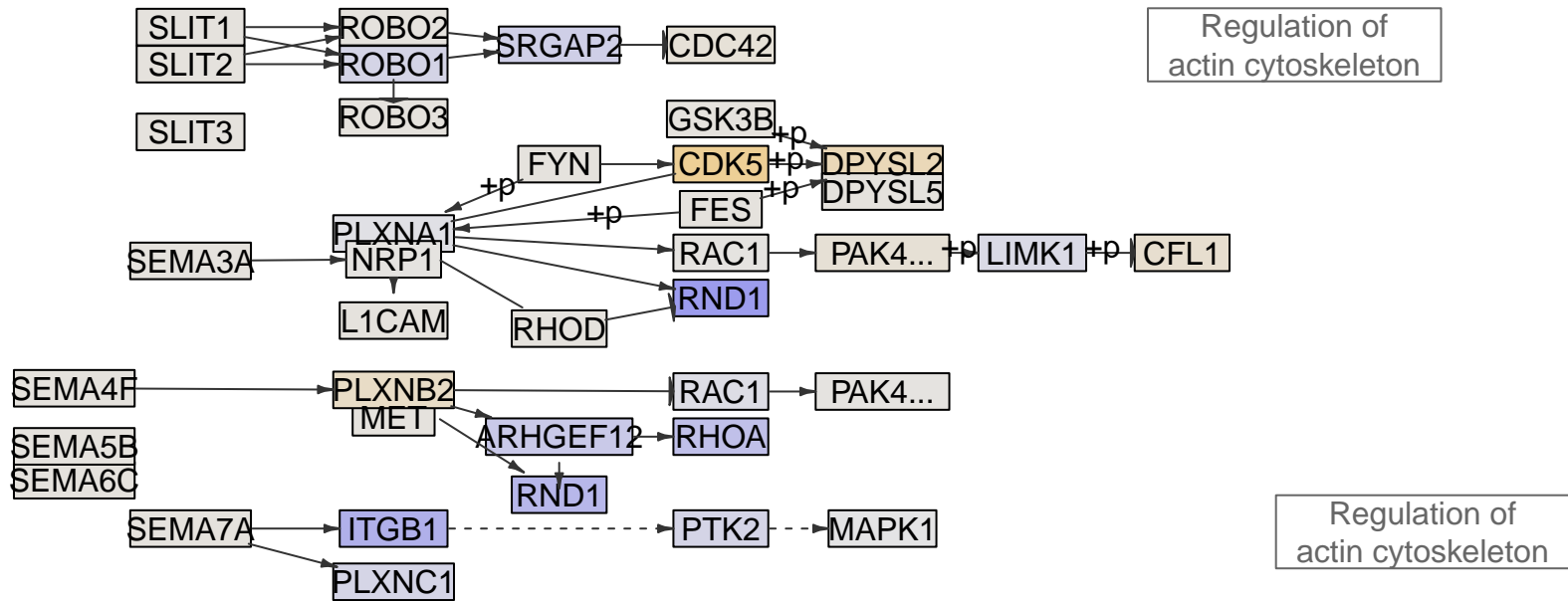

Regulation of actin cytoskeleton

Regulation of actin cytoskeleton

Axon guidance
MPI-202

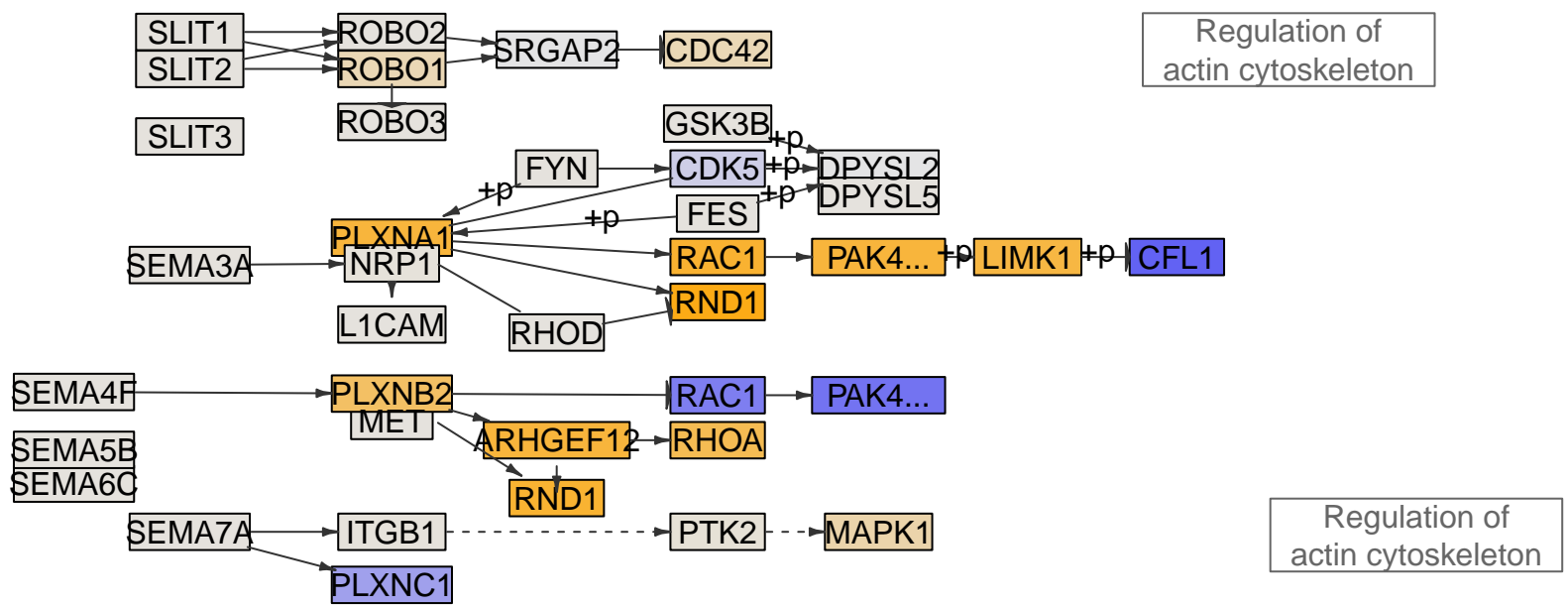
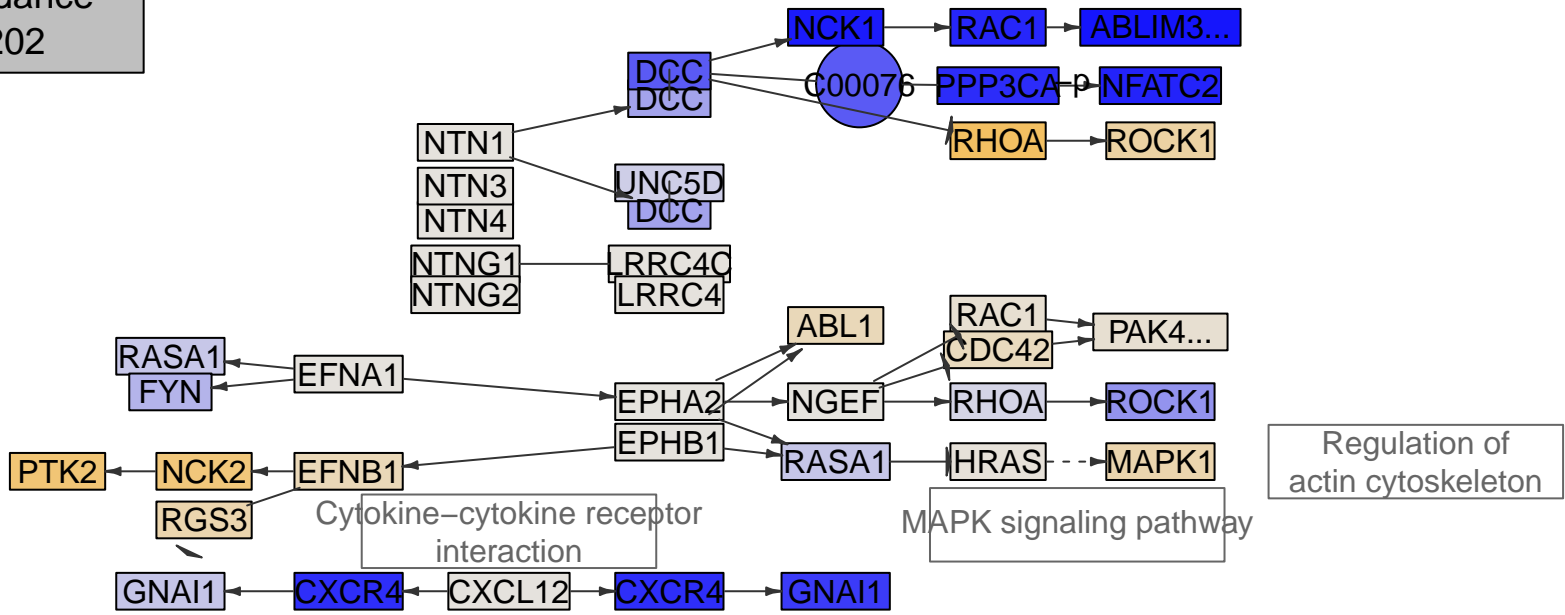

Axon guidance
MPI-203

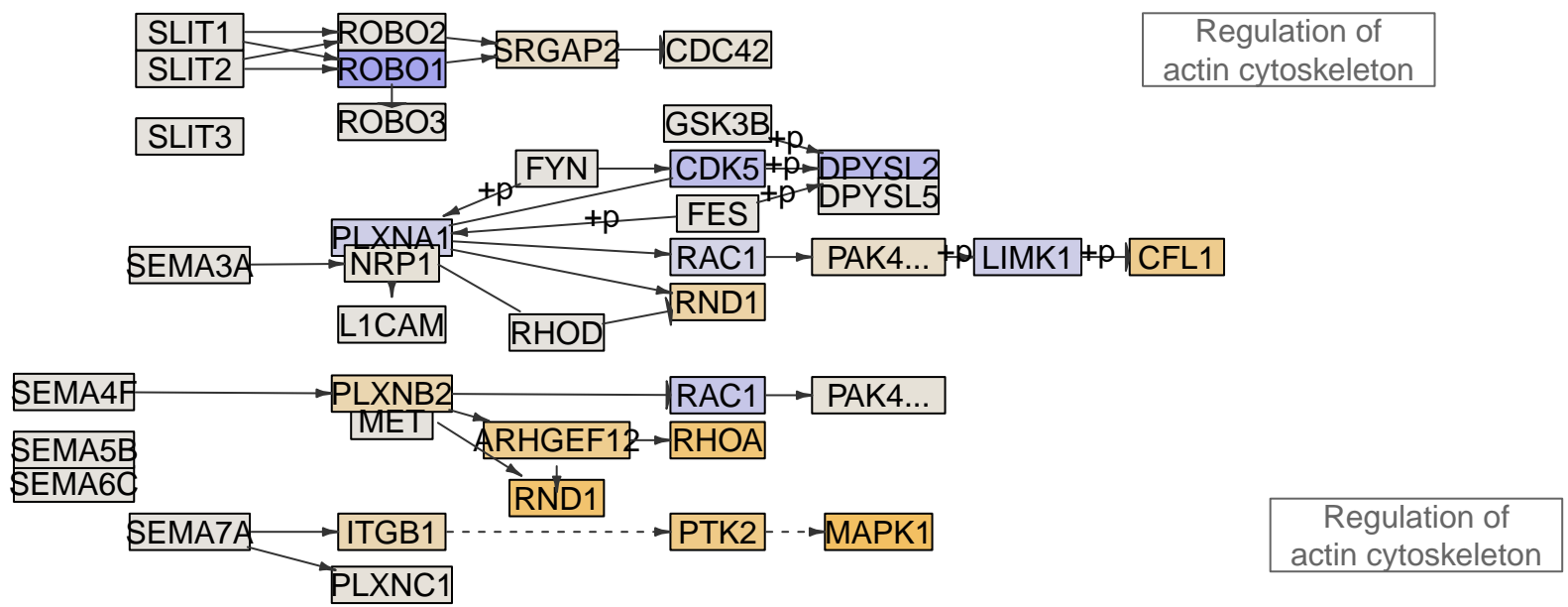
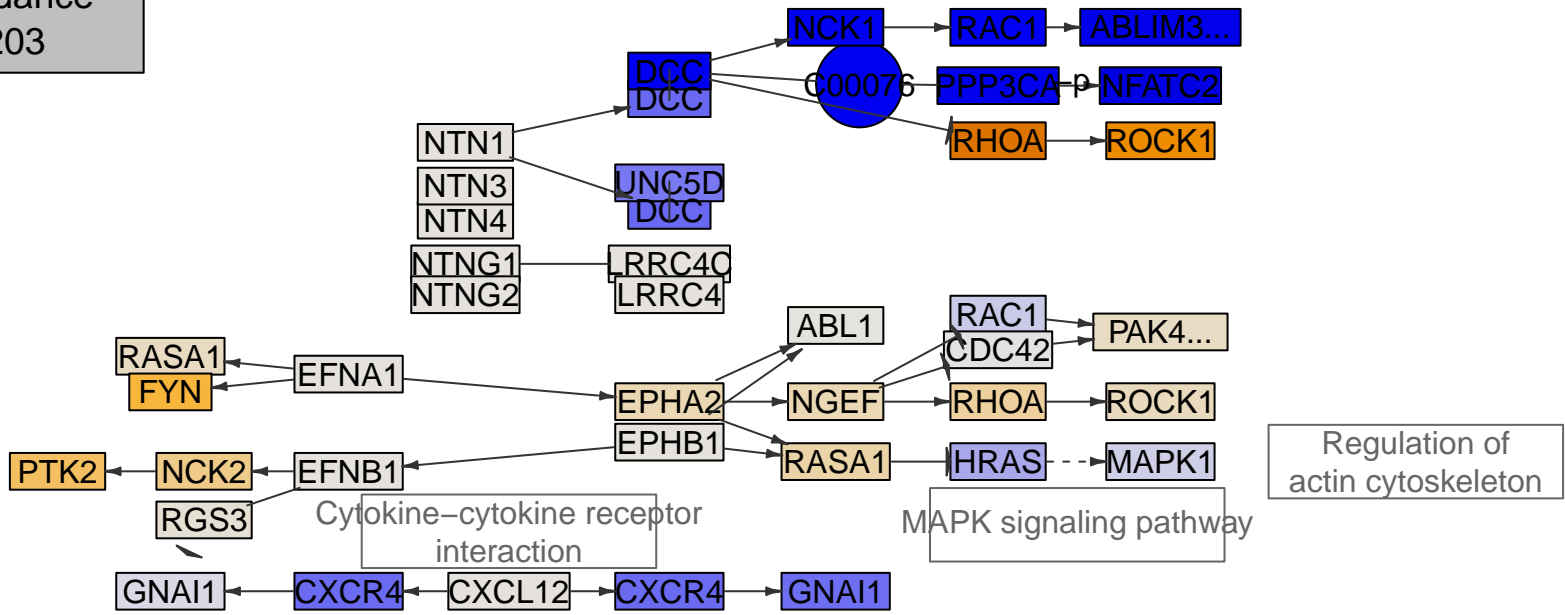

Axon guidance
MPI-204

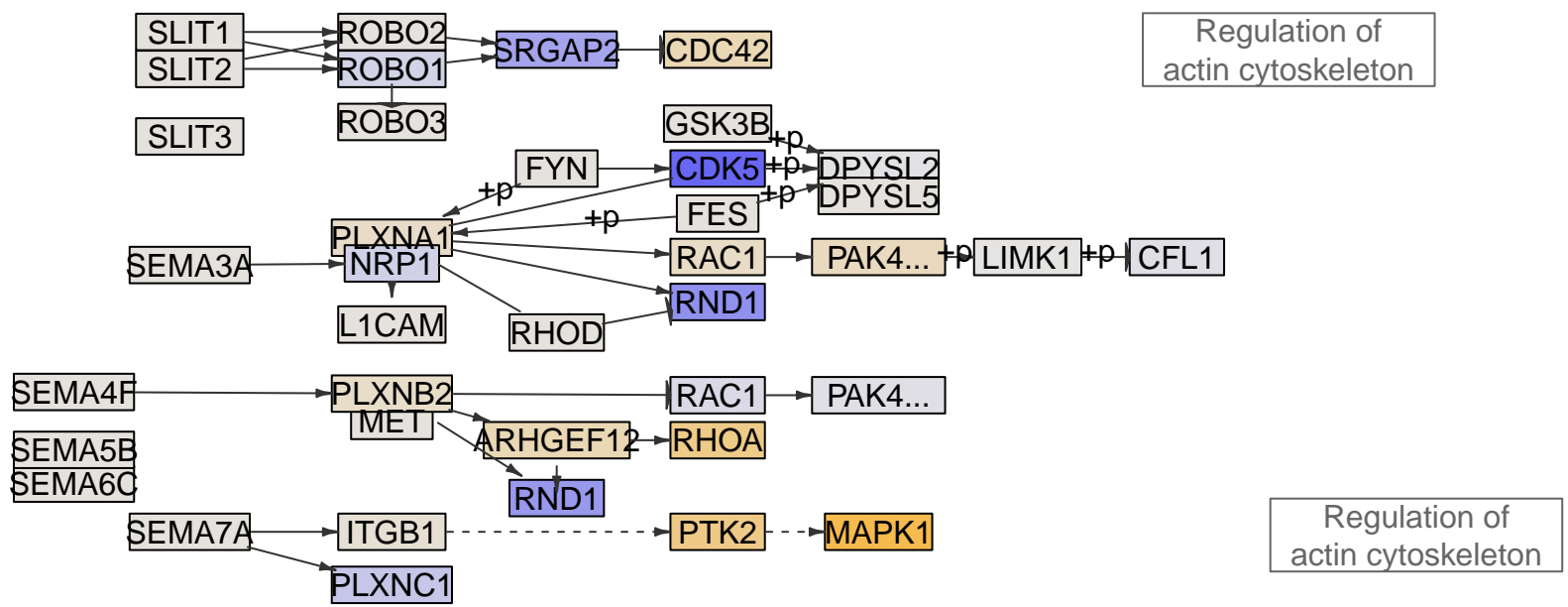
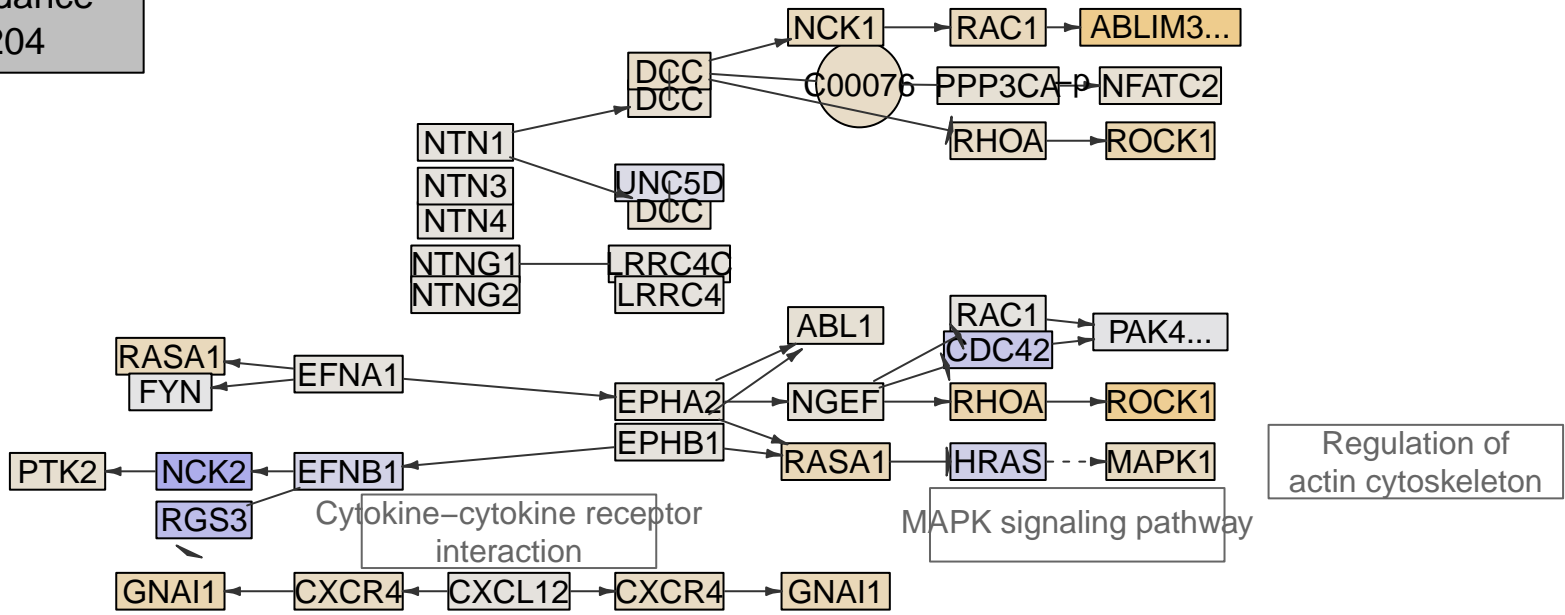

Axon guidance
MPI-205

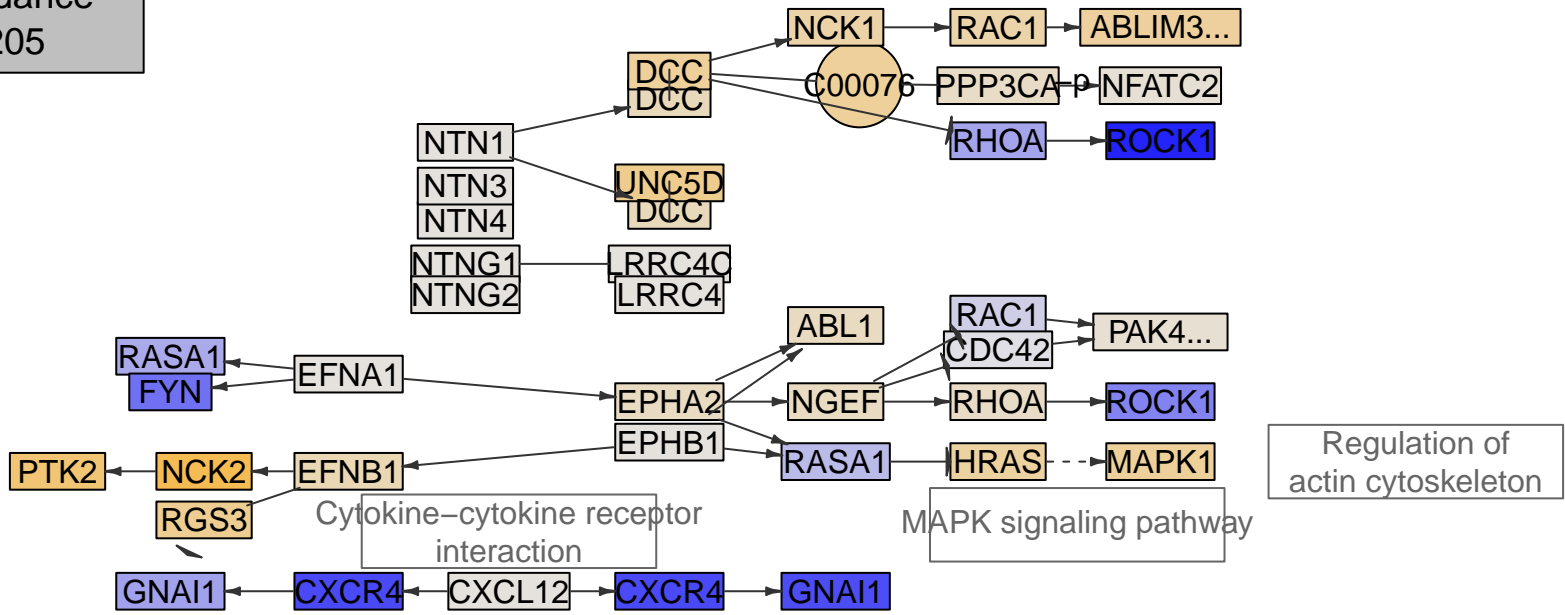

Regulation of actin cytoskeleton

MAPK signaling pathway

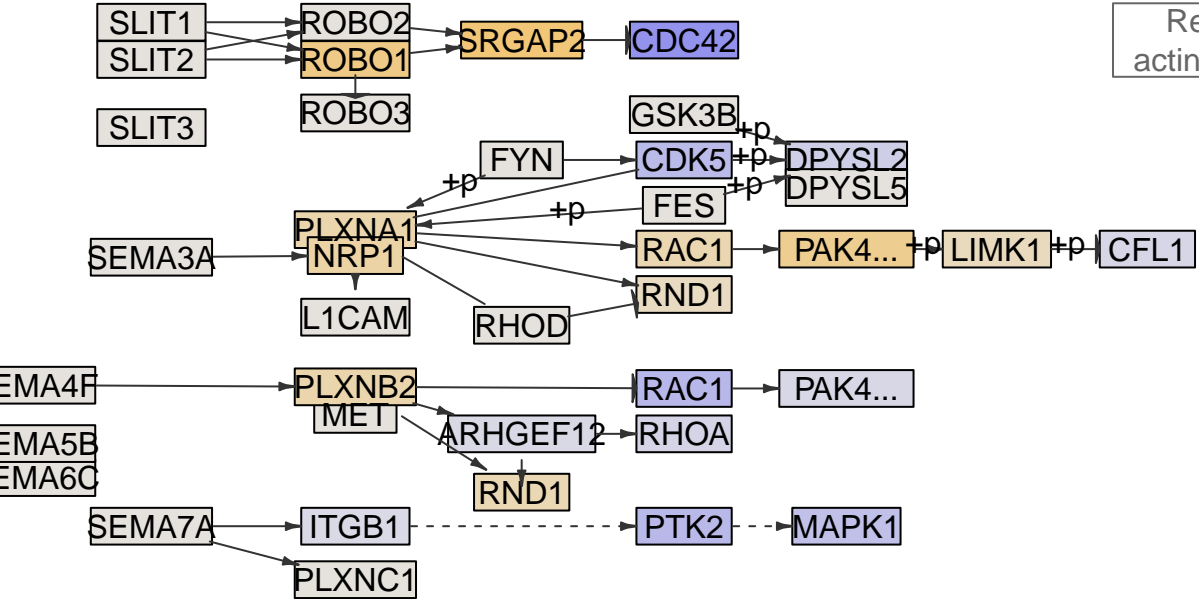

Regulation of actin cytoskeleton

Regulation of actin cytoskeleton

Axon guidance
MPI-206

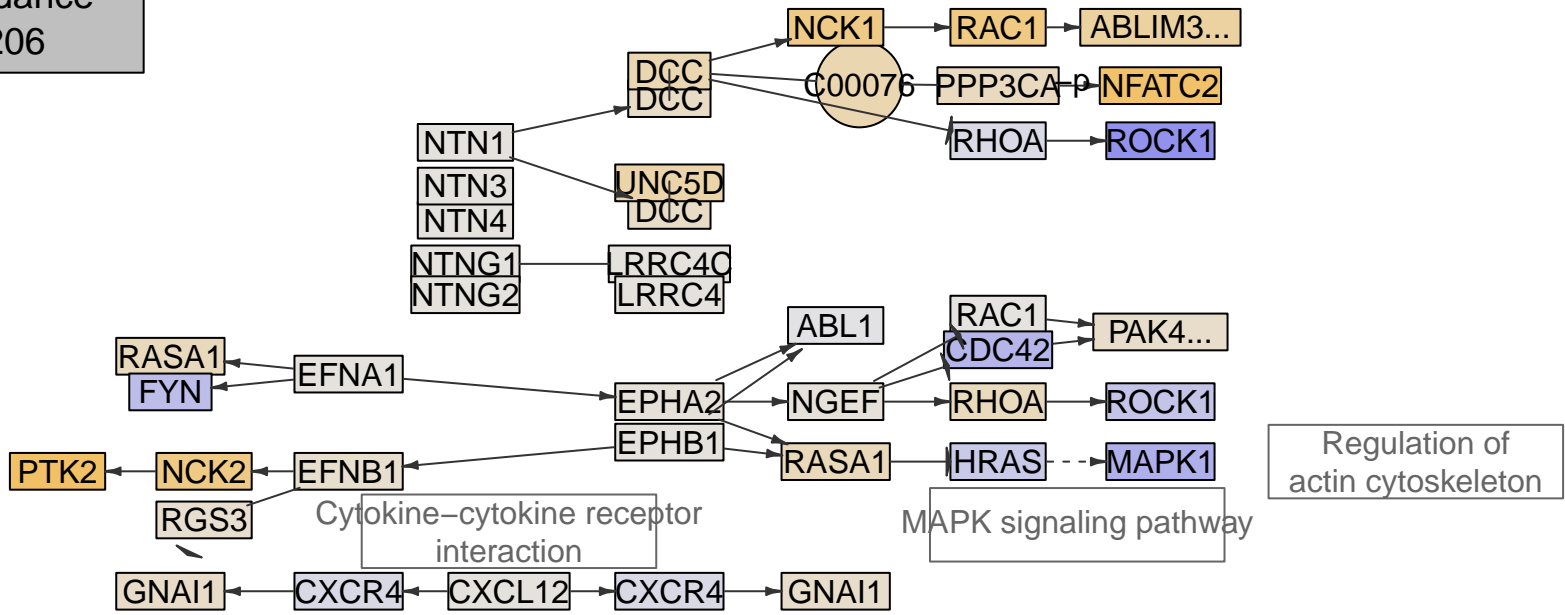

Regulation of actin cytoskeleton

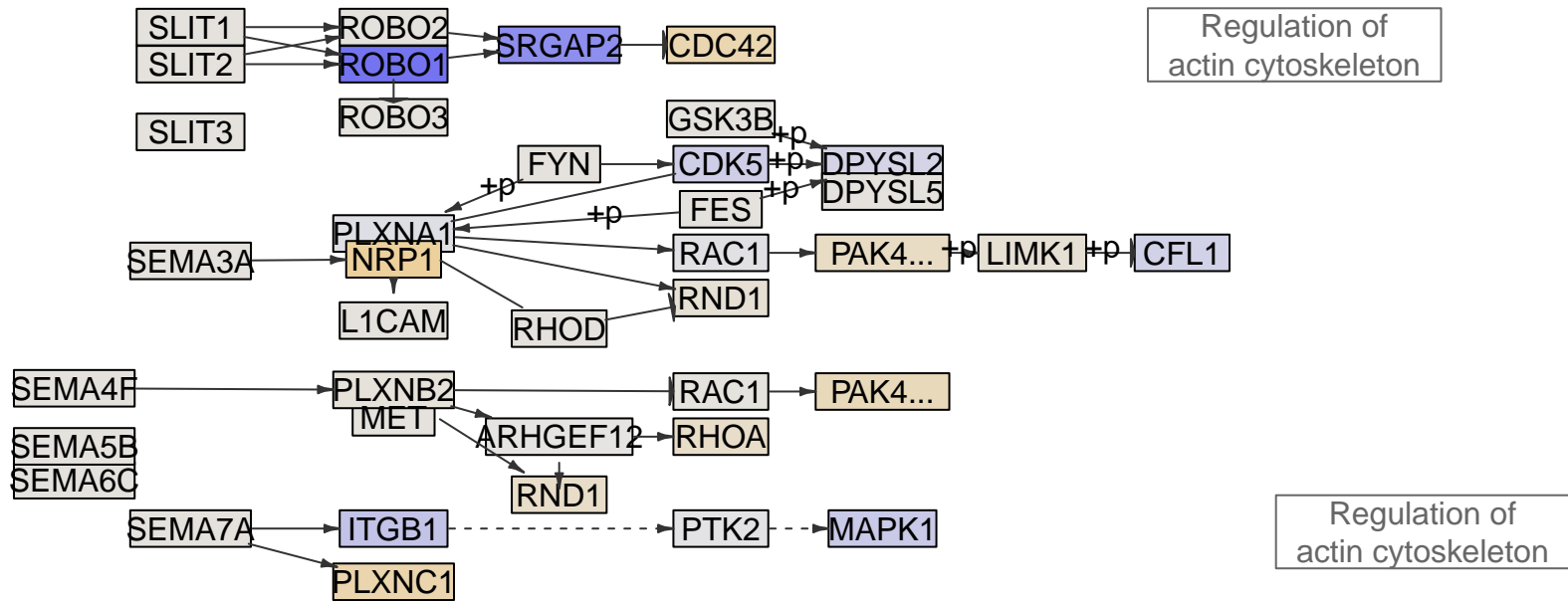

Regulation of actin cytoskeleton

Regulation of actin cytoskeleton

Axon guidance
MPI-207

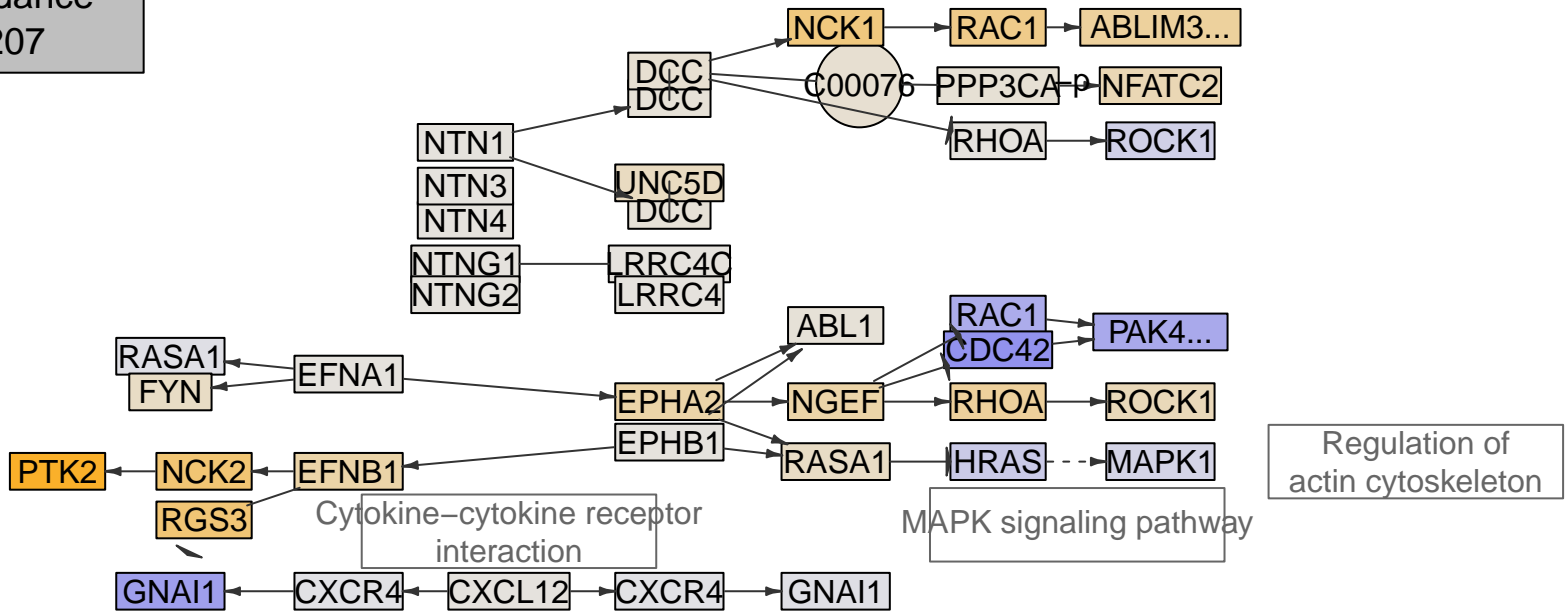

Regulation of actin cytoskeleton

MAPK signaling pathway

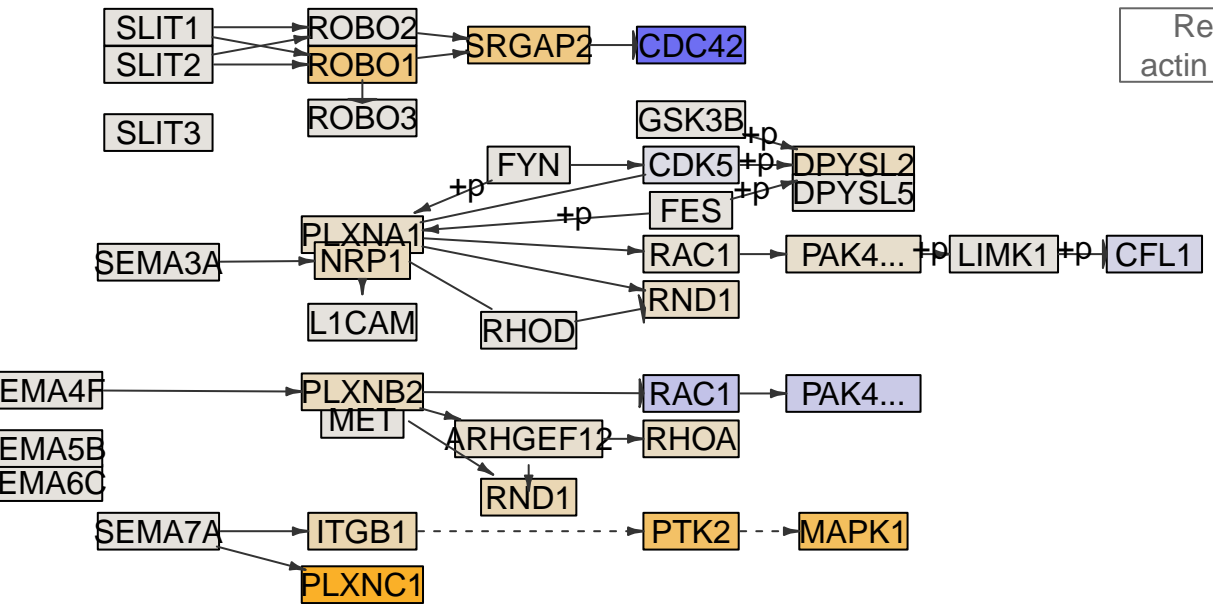

Regulation of actin cytoskeleton

Regulation of actin cytoskeleton

Axon guidance
MPI-208

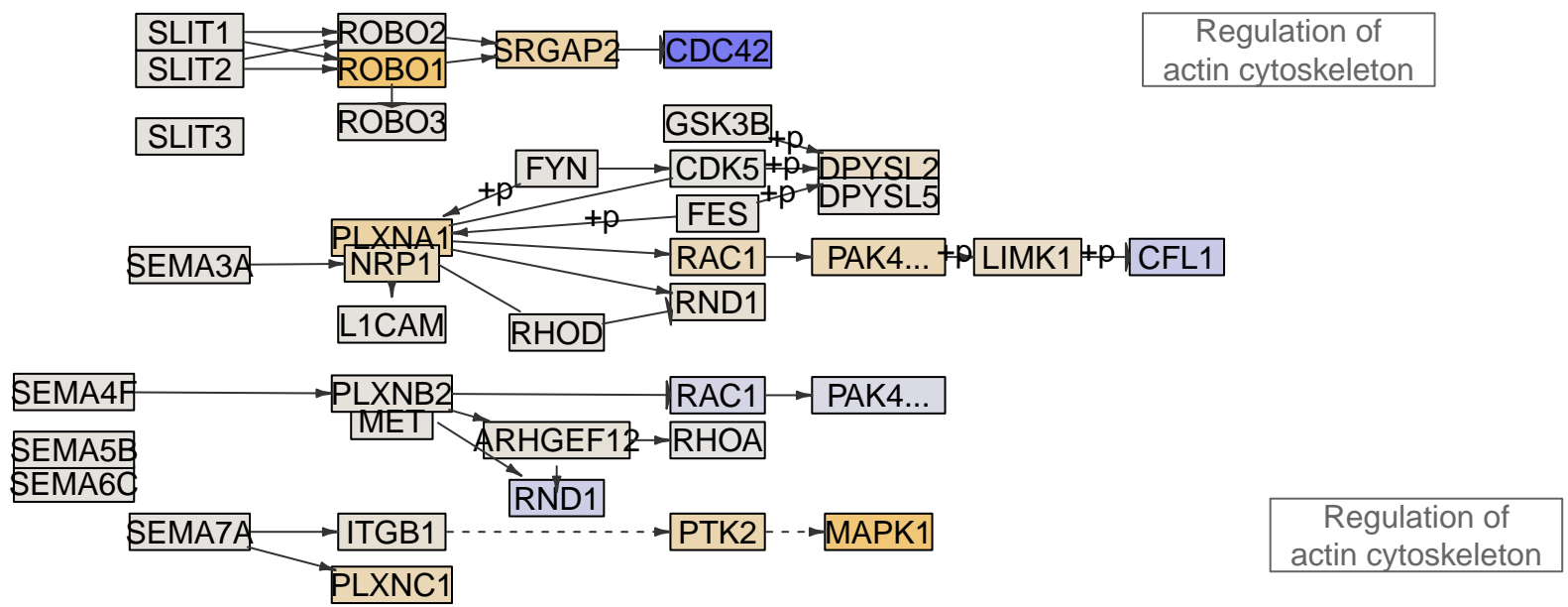
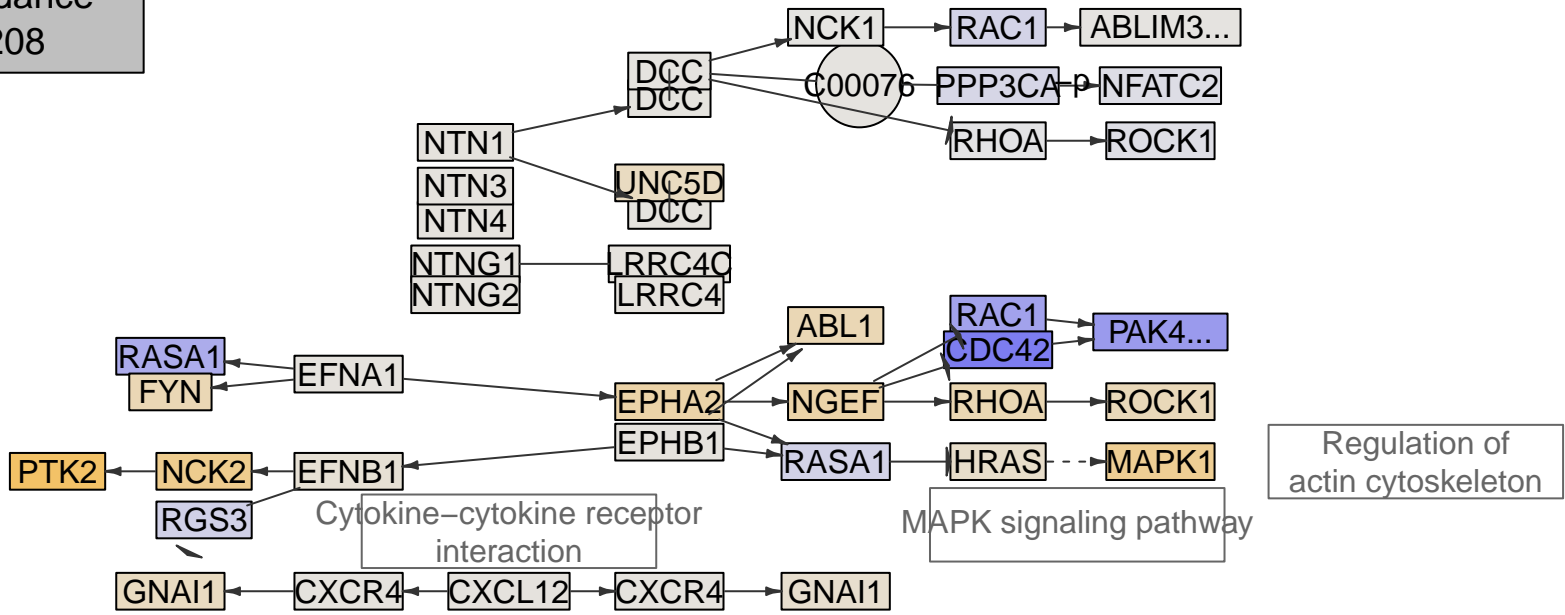

Axon guidance
MPI-209

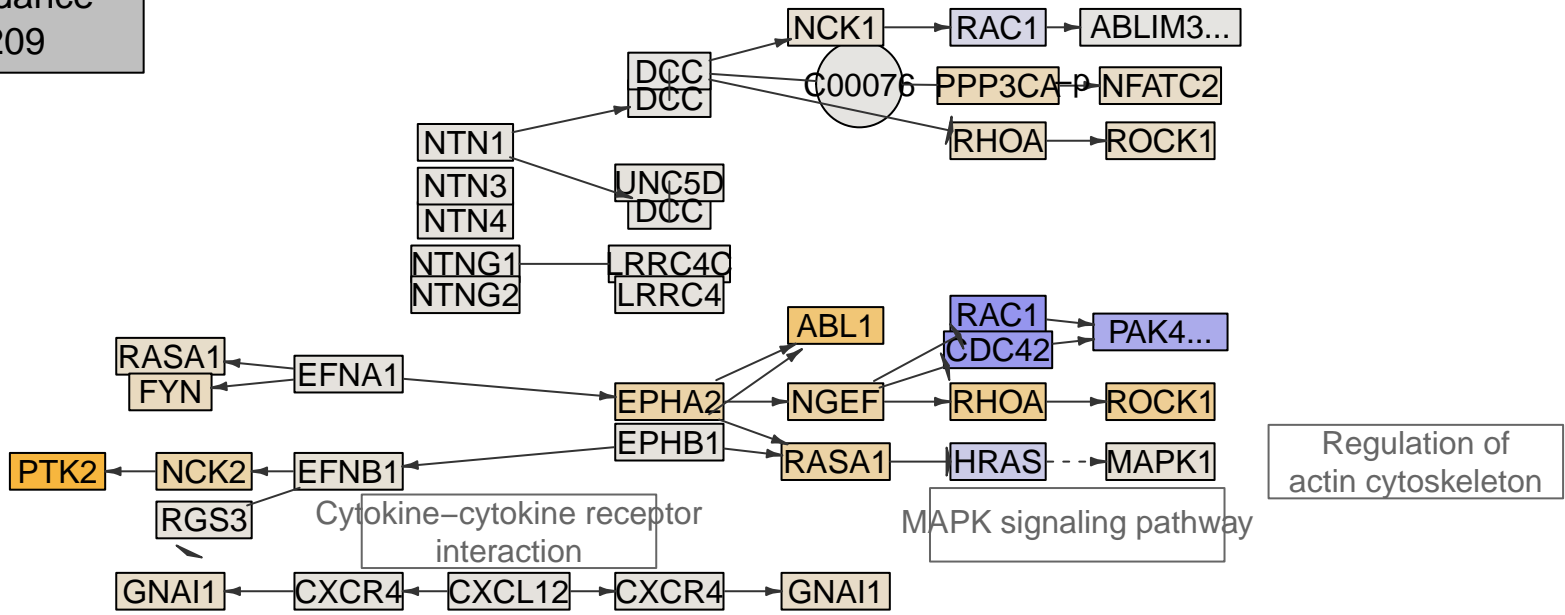

Regulation of actin cytoskeleton

MAPK signaling pathway

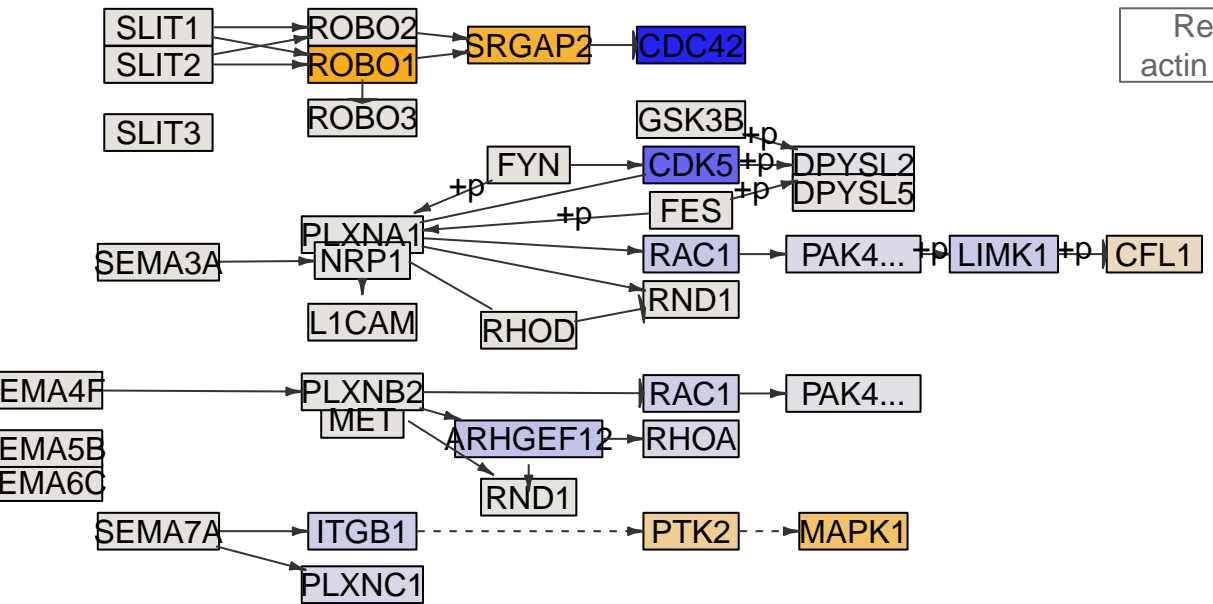

Regulation of actin cytoskeleton

Regulation of actin cytoskeleton

Axon guidance
MPI-210

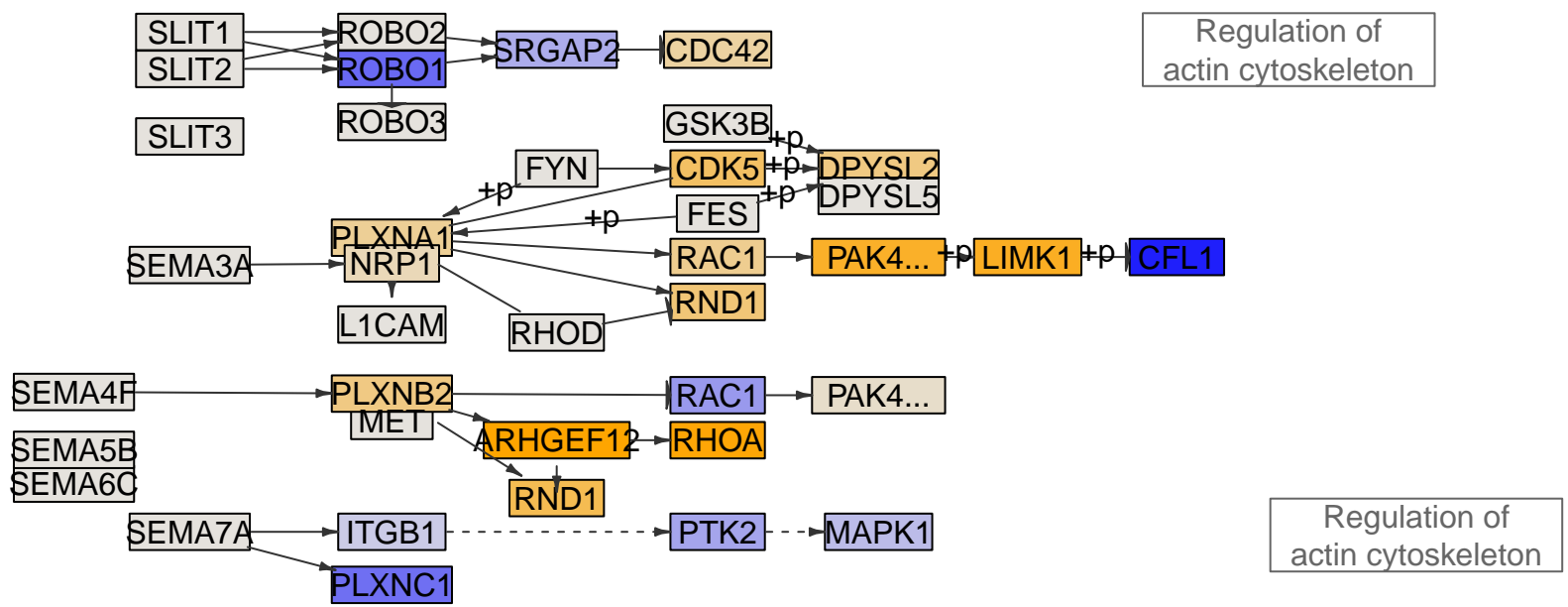
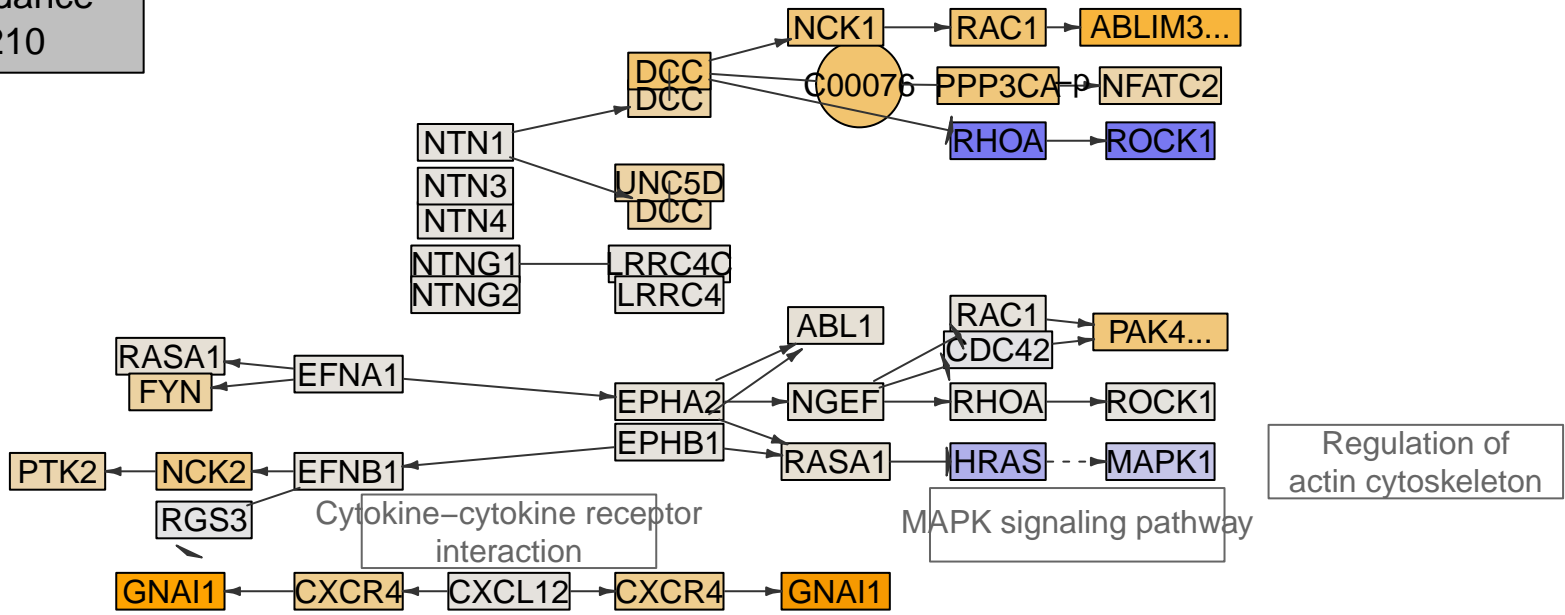

Axon guidance
MPI-212

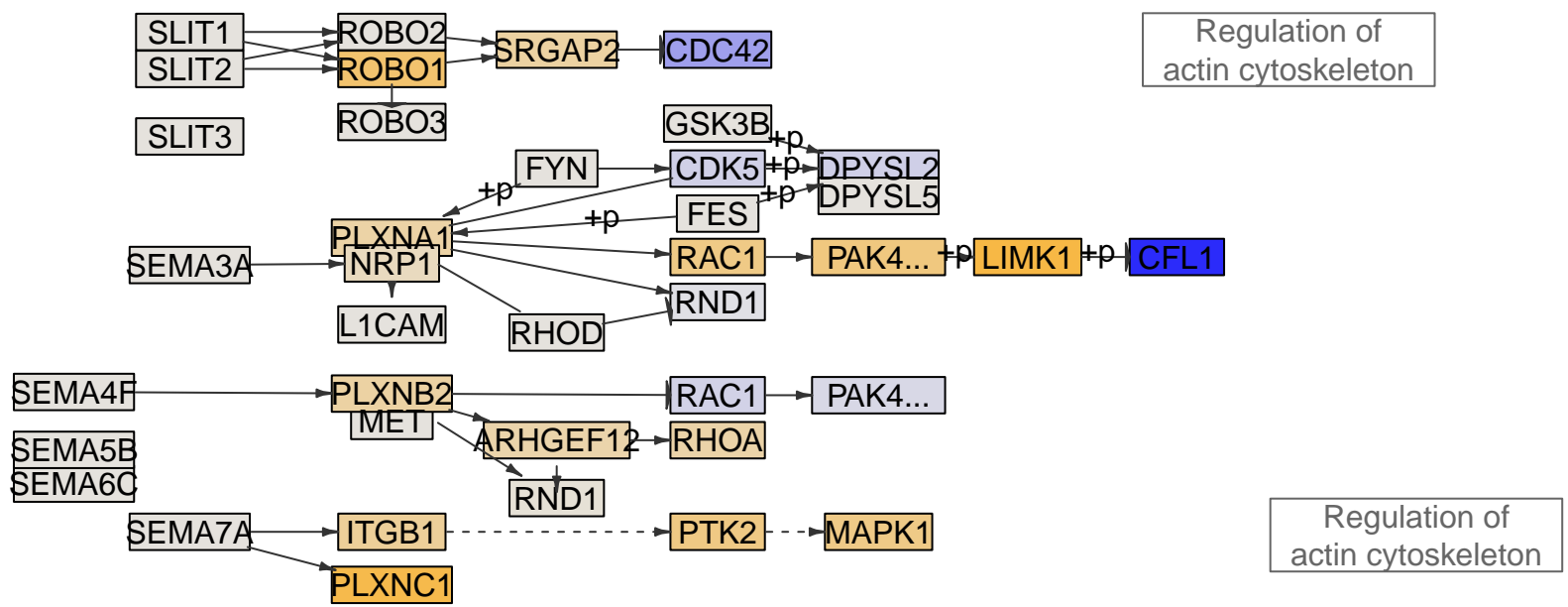
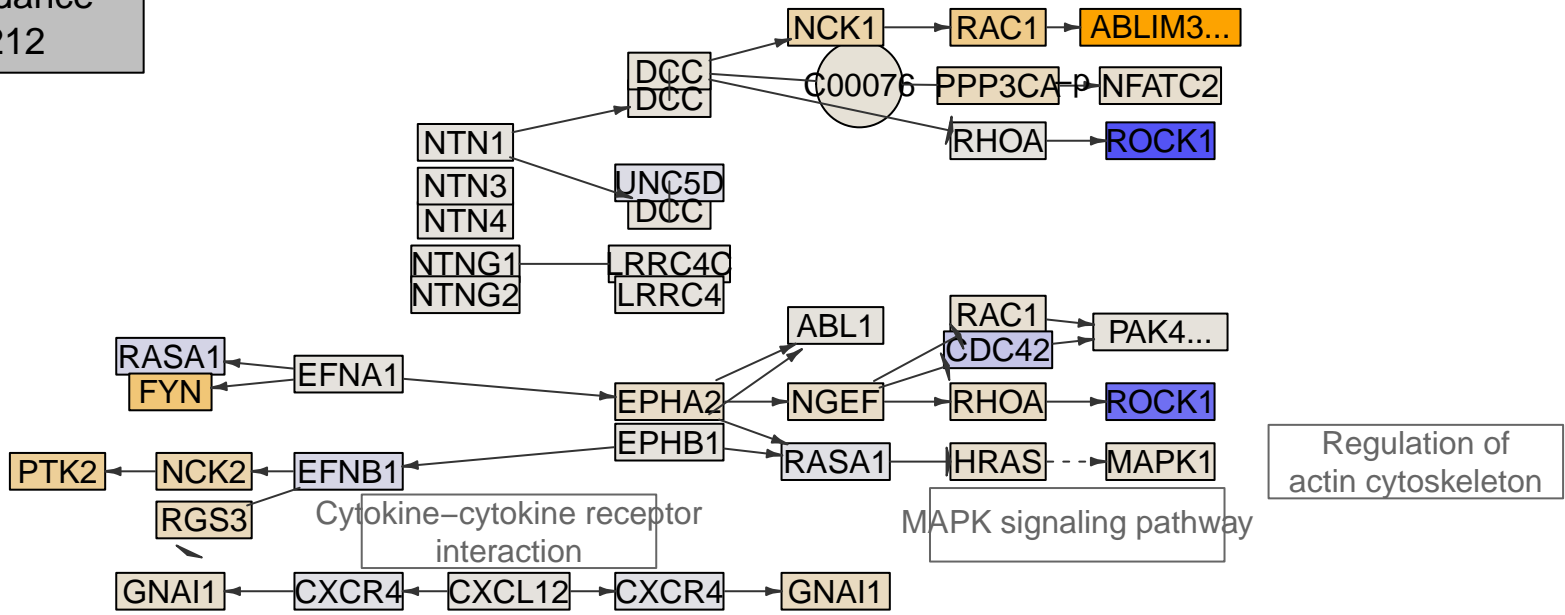

Axon guidance
MPI-213

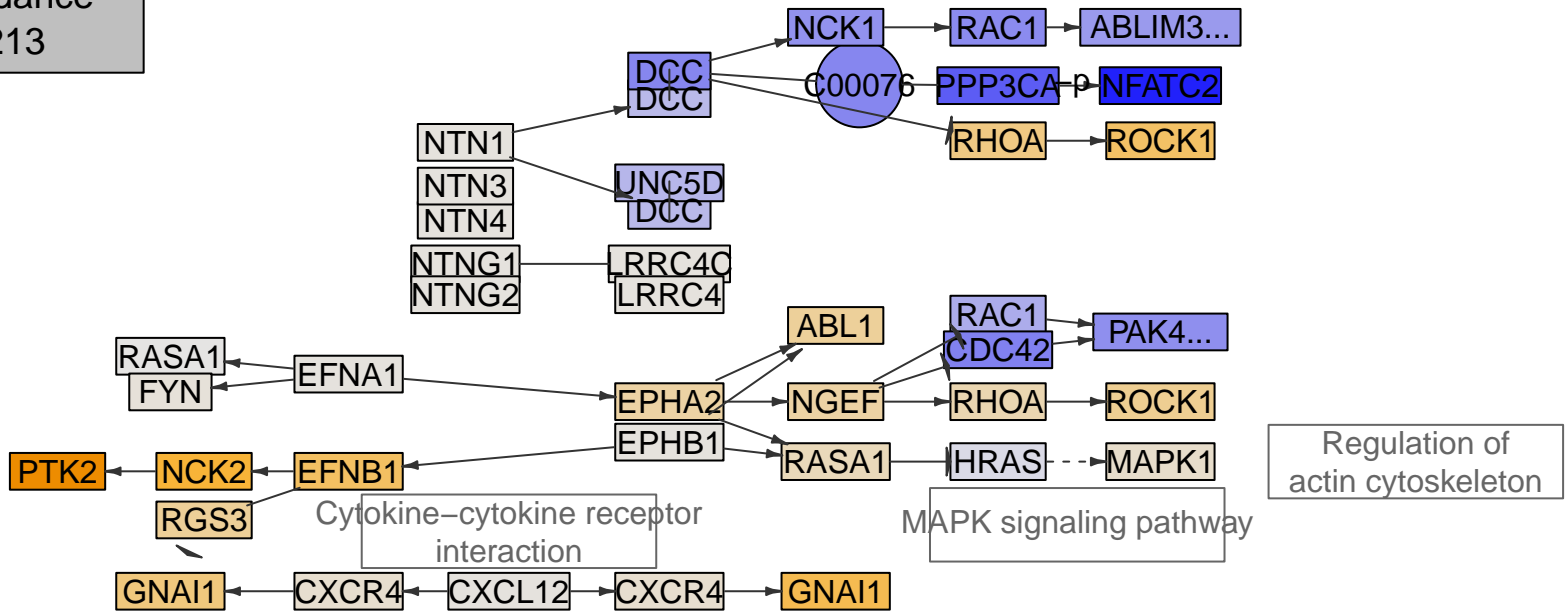

Regulation of actin cytoskeleton

MAPK signaling pathway

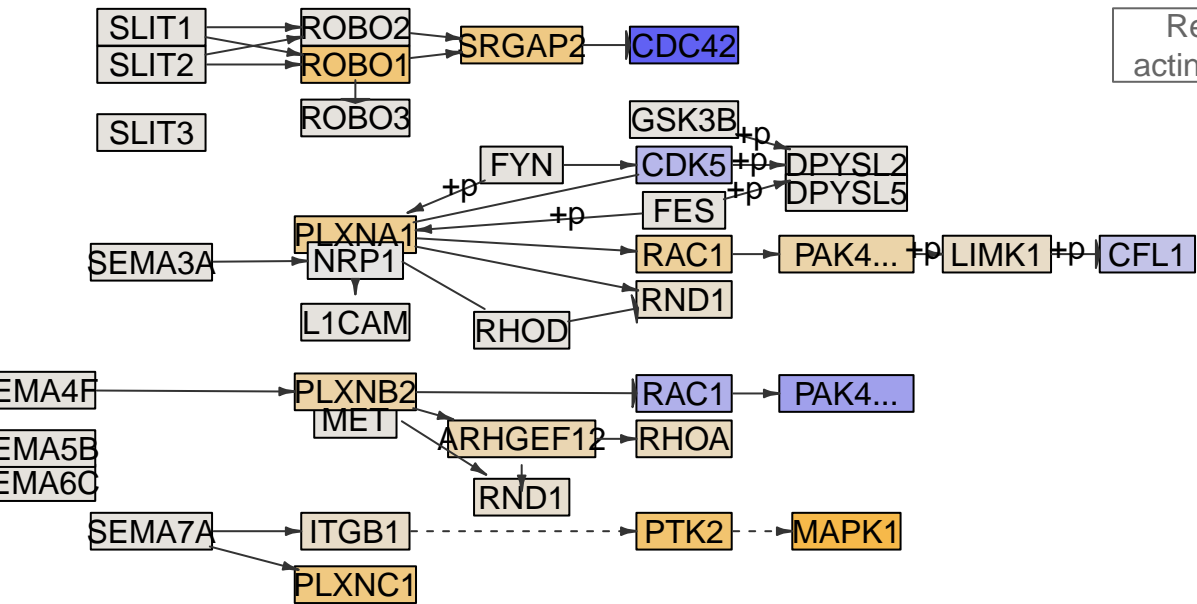

Regulation of actin cytoskeleton

Regulation of actin cytoskeleton

Axon guidance
MPI-215

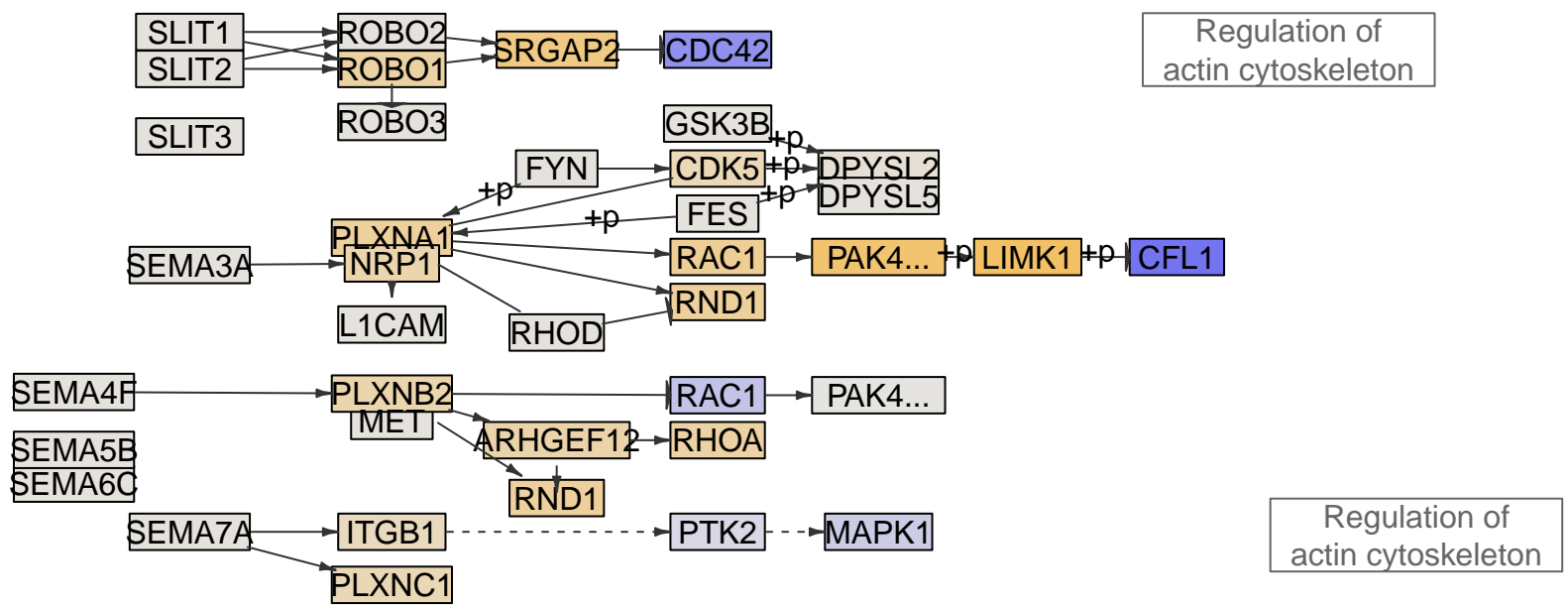
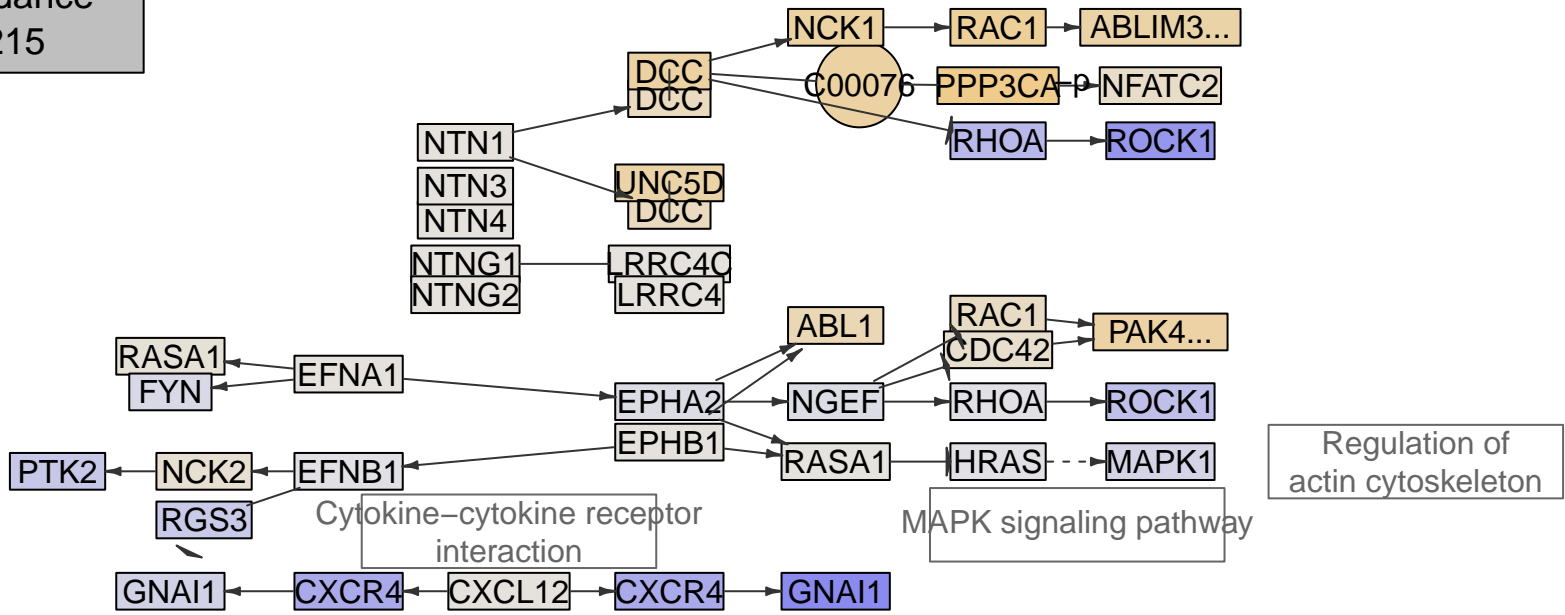

Axon guidance
MPI-219

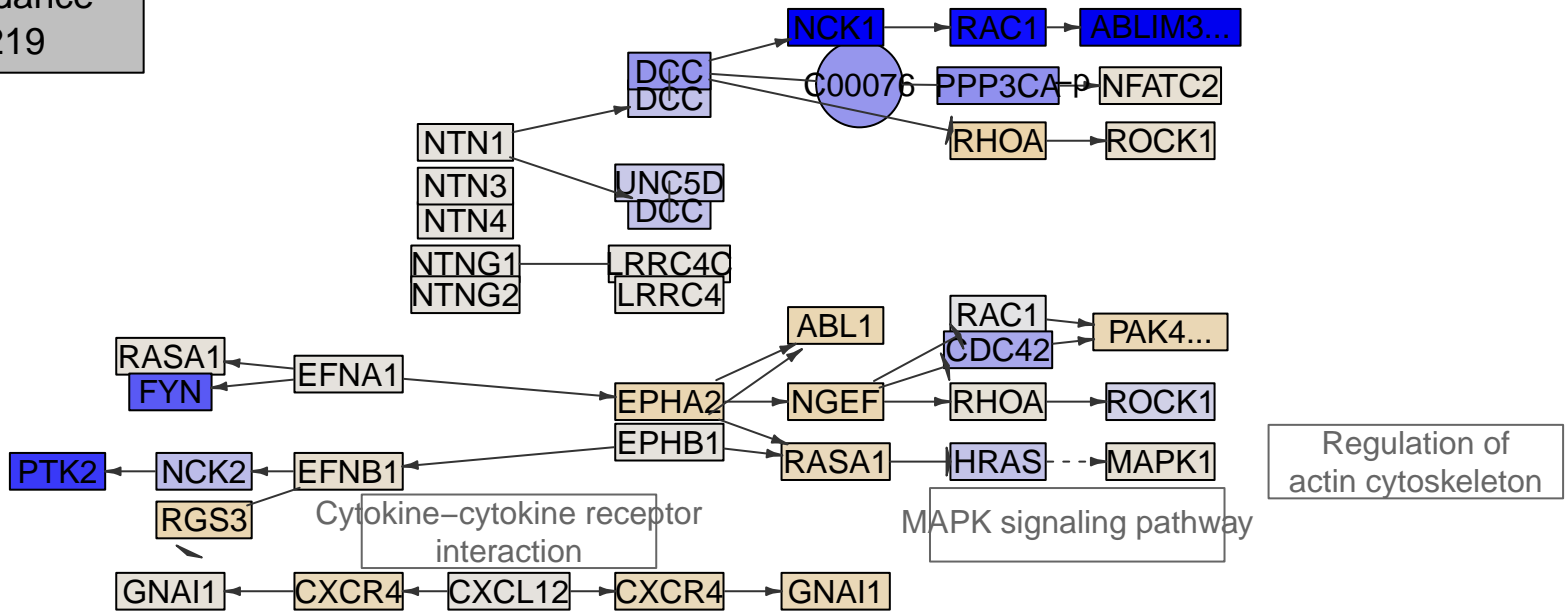

Regulation of actin cytoskeleton

MAPK signaling pathway

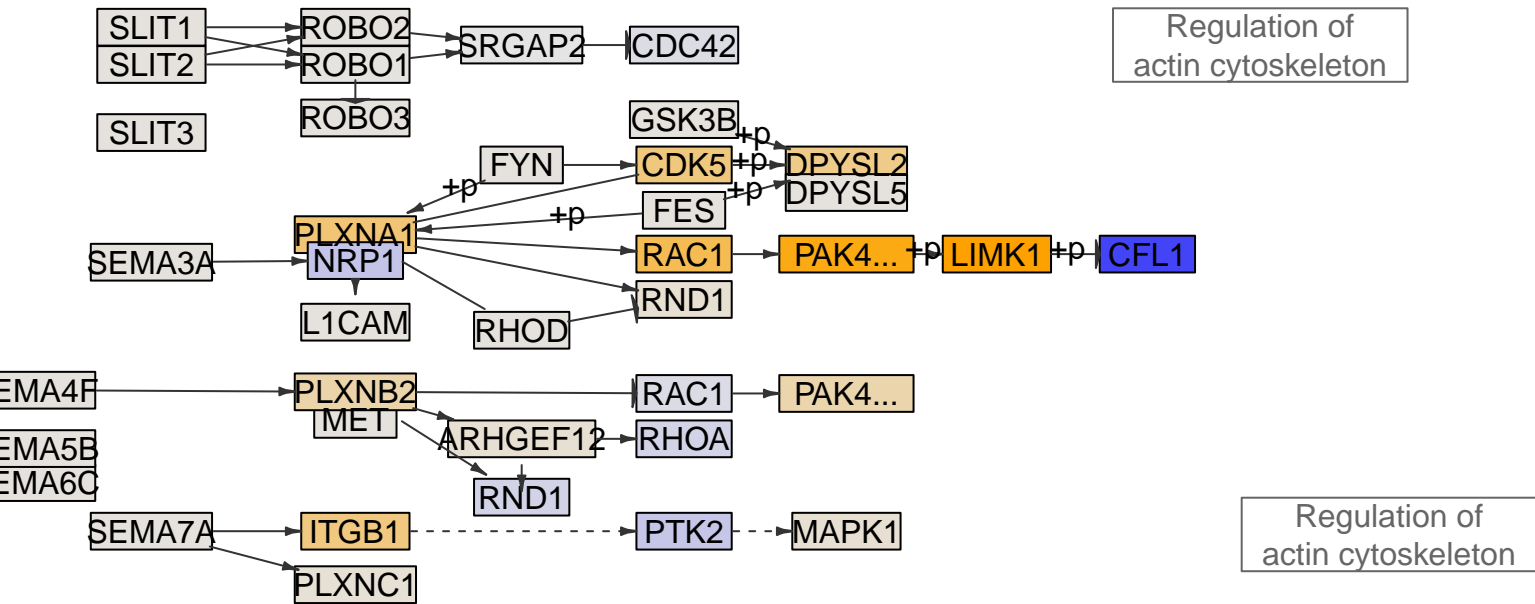

Regulation of actin cytoskeleton

Regulation of actin cytoskeleton

Axon guidance
MPI-221

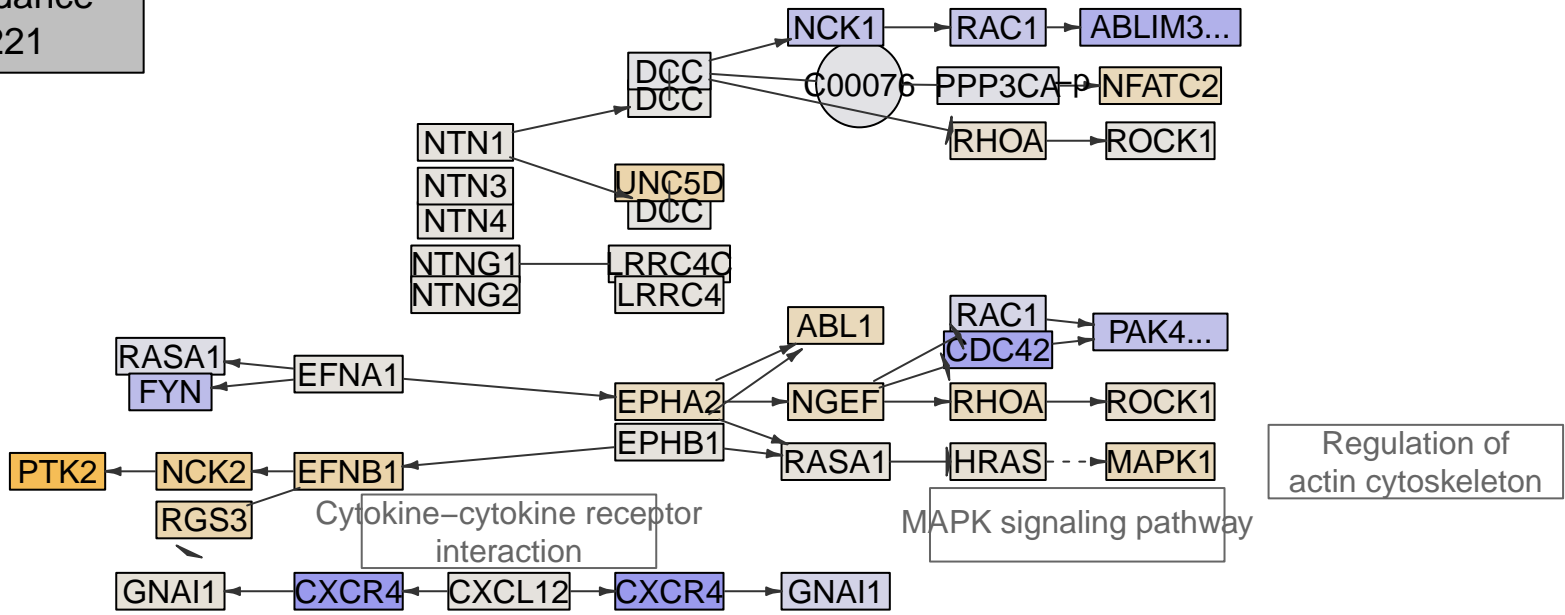

Regulation of actin cytoskeleton

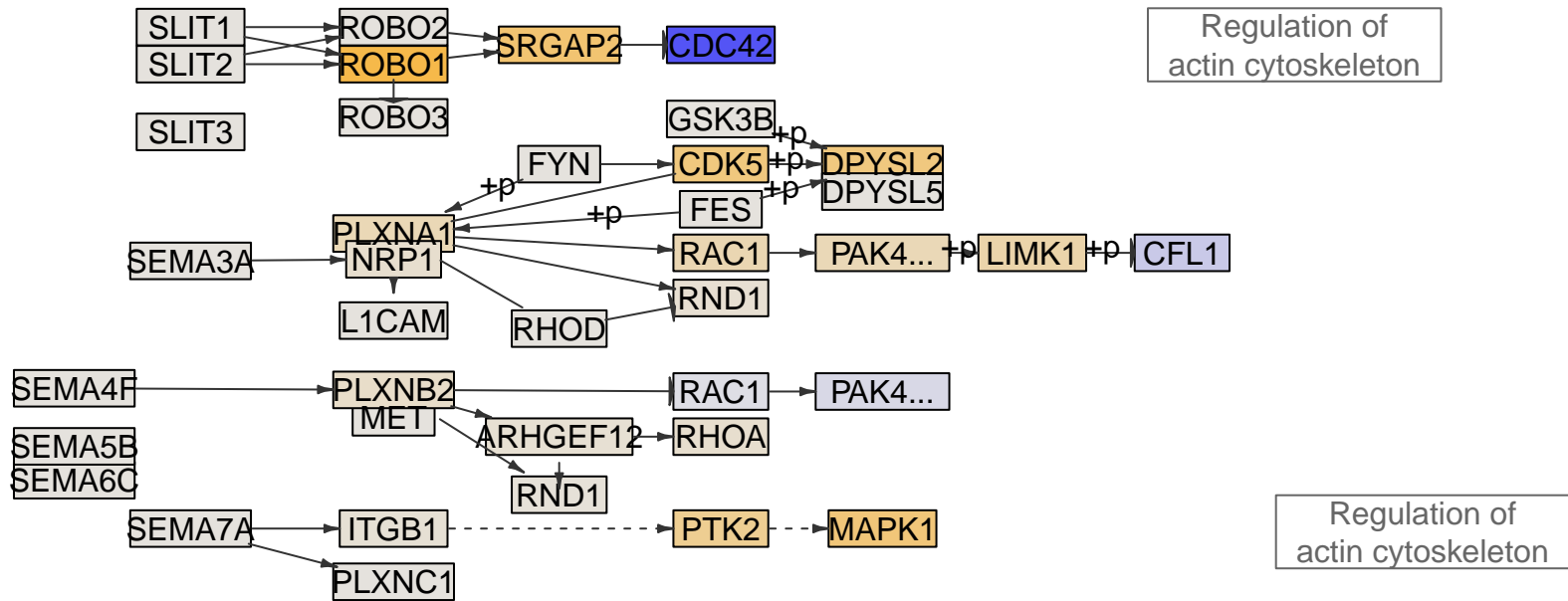

Regulation of actin cytoskeleton

Regulation of actin cytoskeleton

Axon guidance
MPI-223a

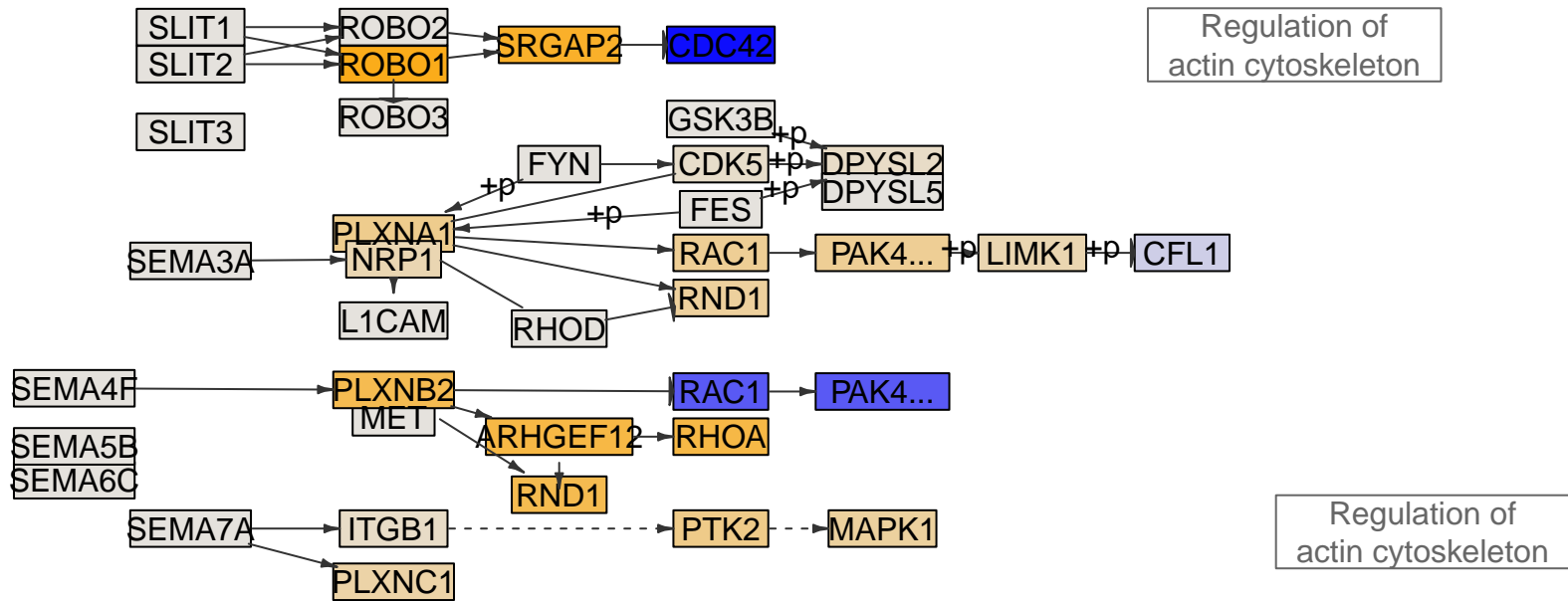
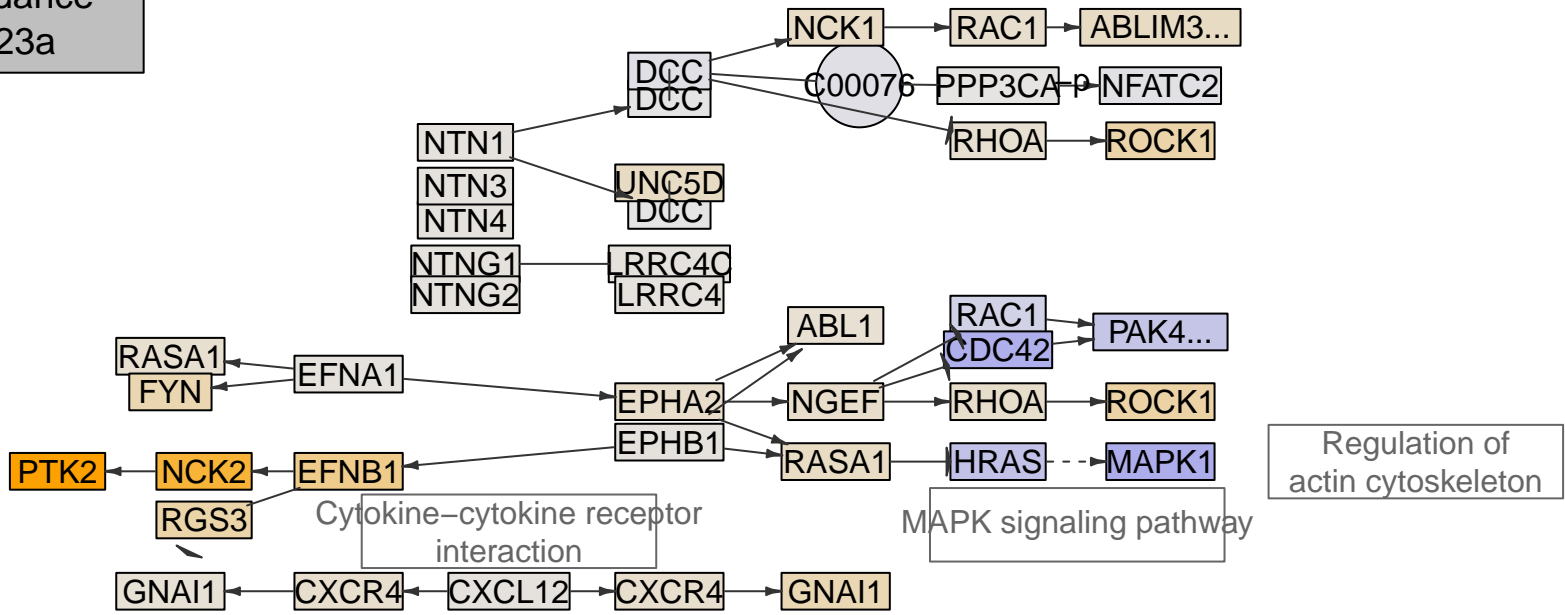

Axon guidance
MPI-224

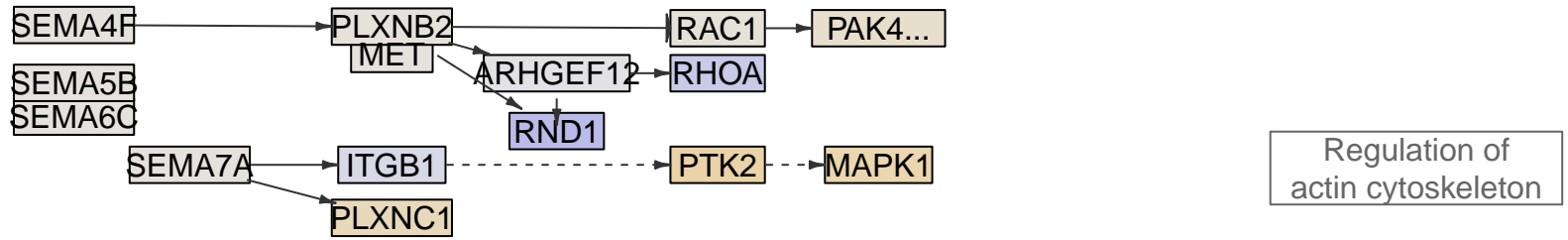
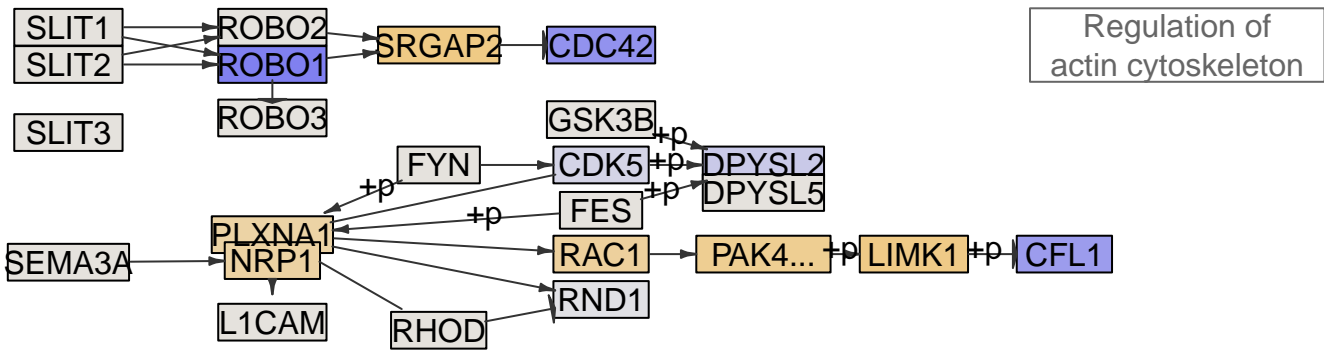
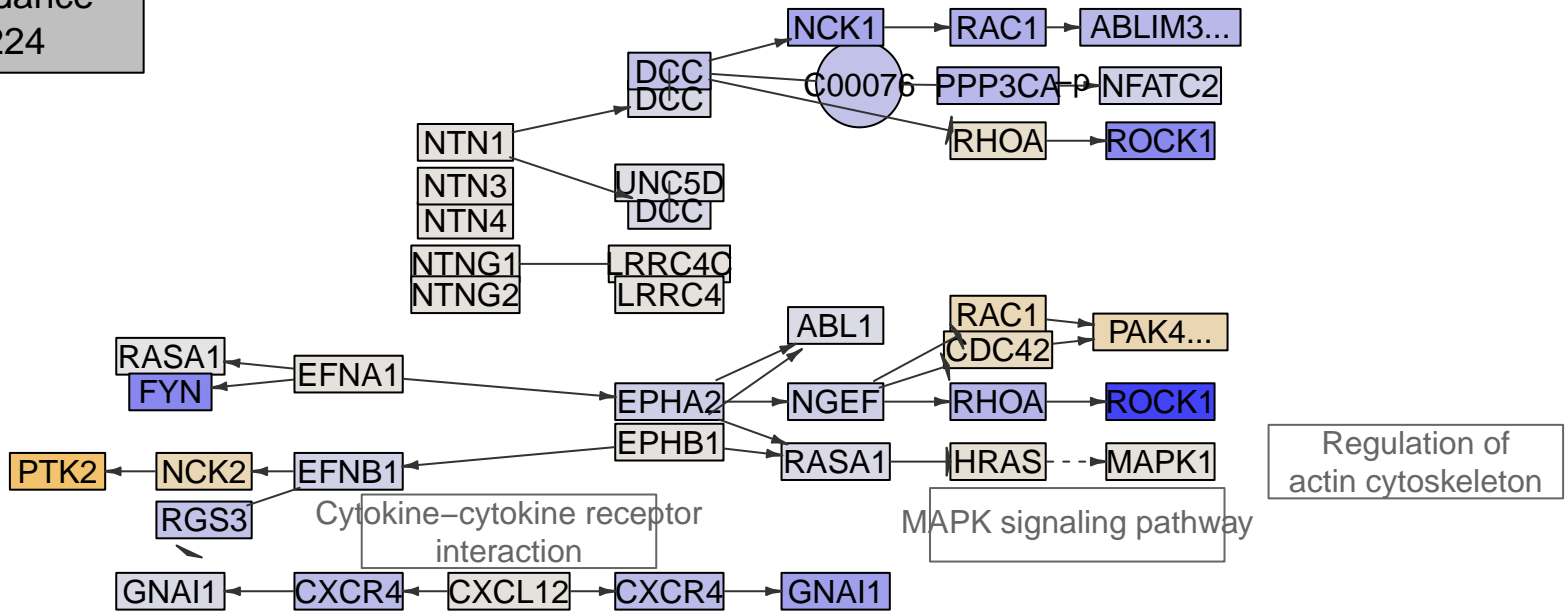

Axon guidance
MPI-226

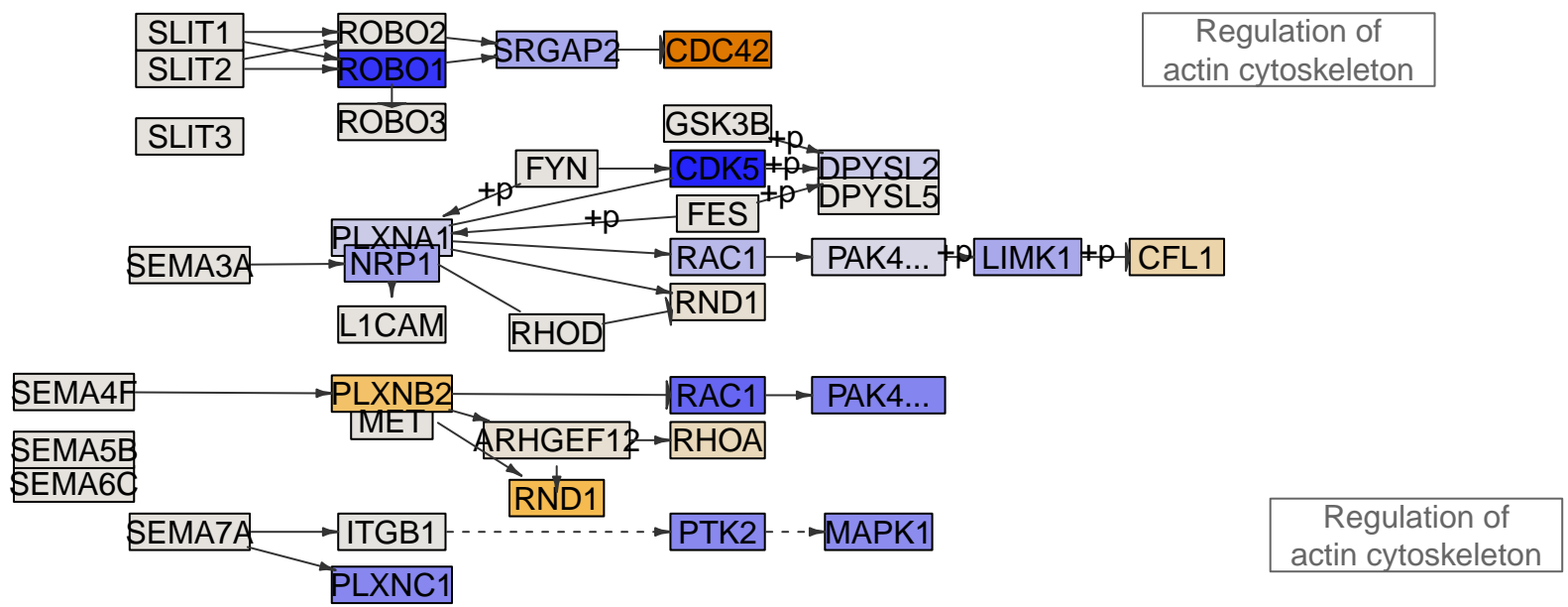
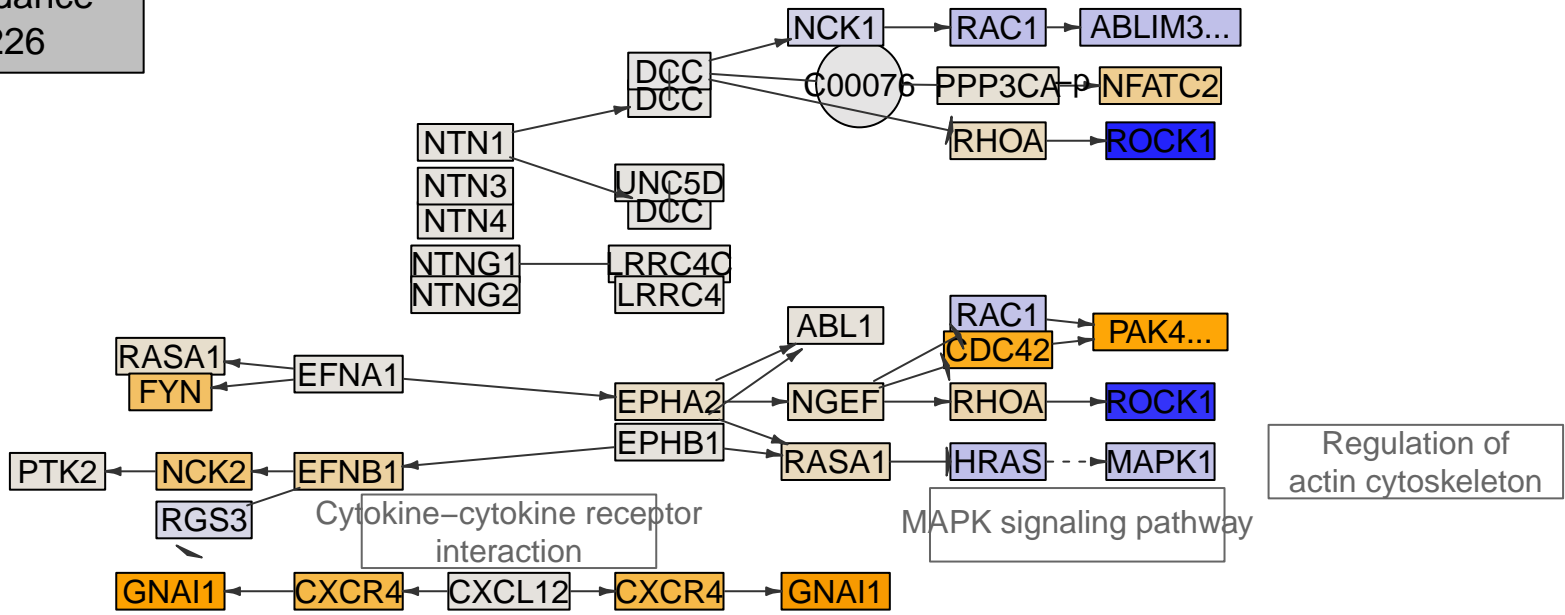

Axon guidance
MPI-227

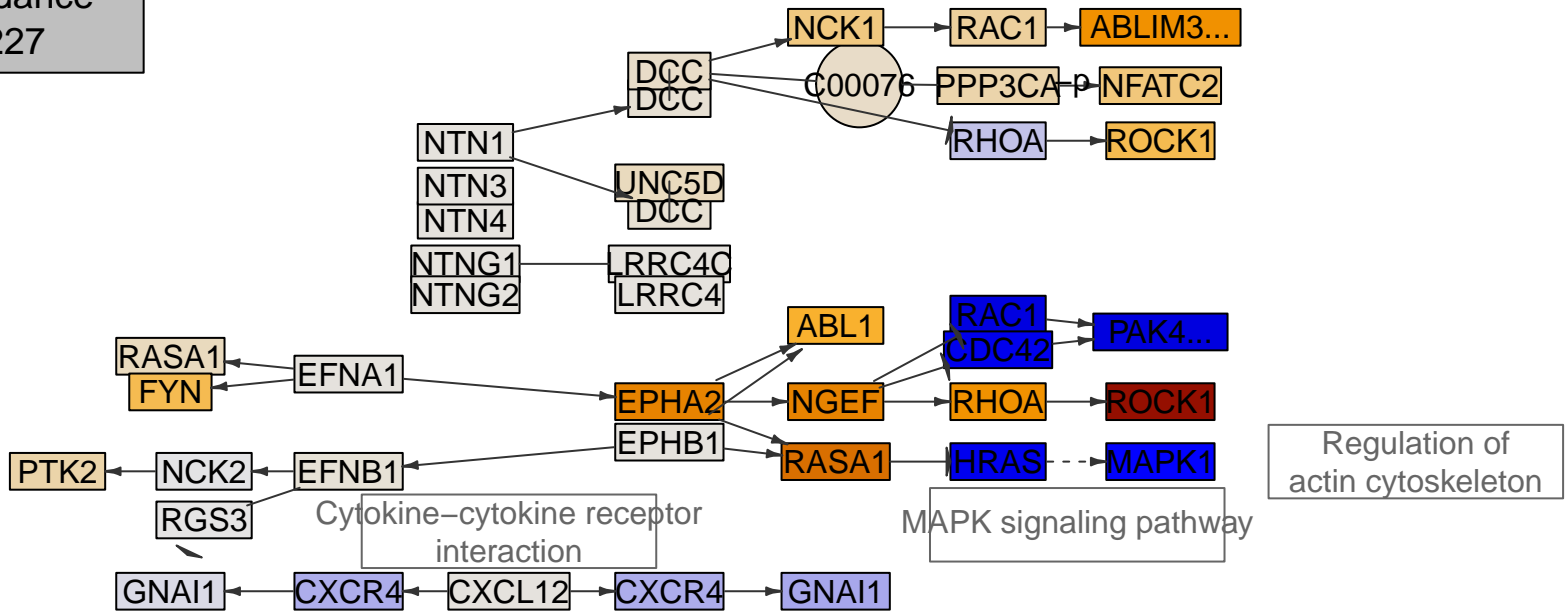

Regulation of actin cytoskeleton

MAPK signaling pathway

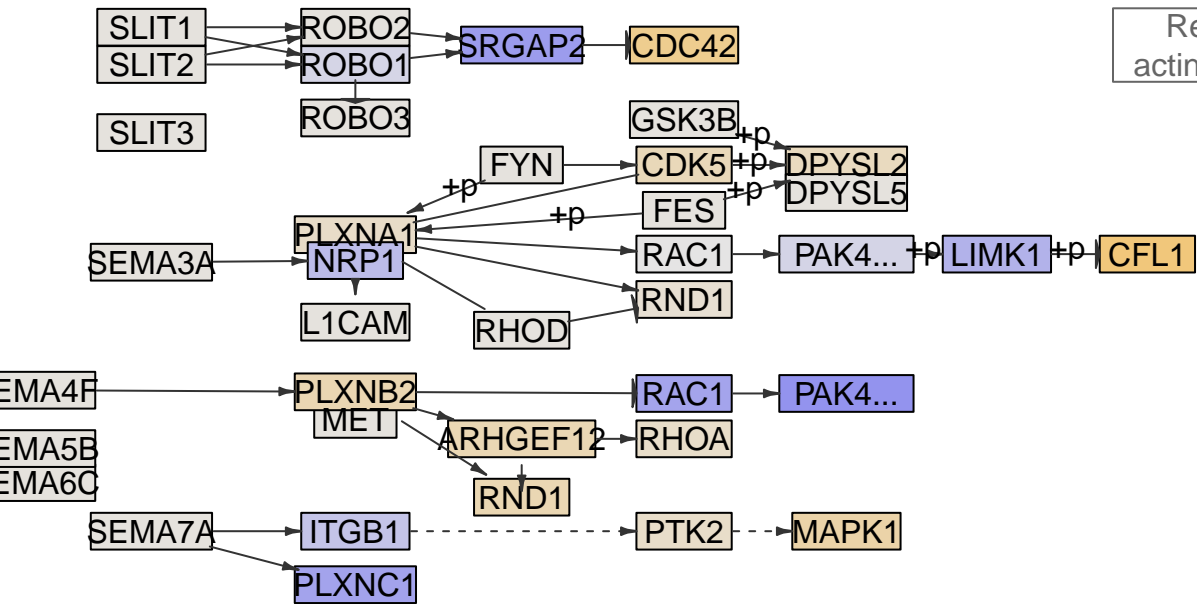

Regulation of actin cytoskeleton

Regulation of actin cytoskeleton

Axon guidance
MPI-228

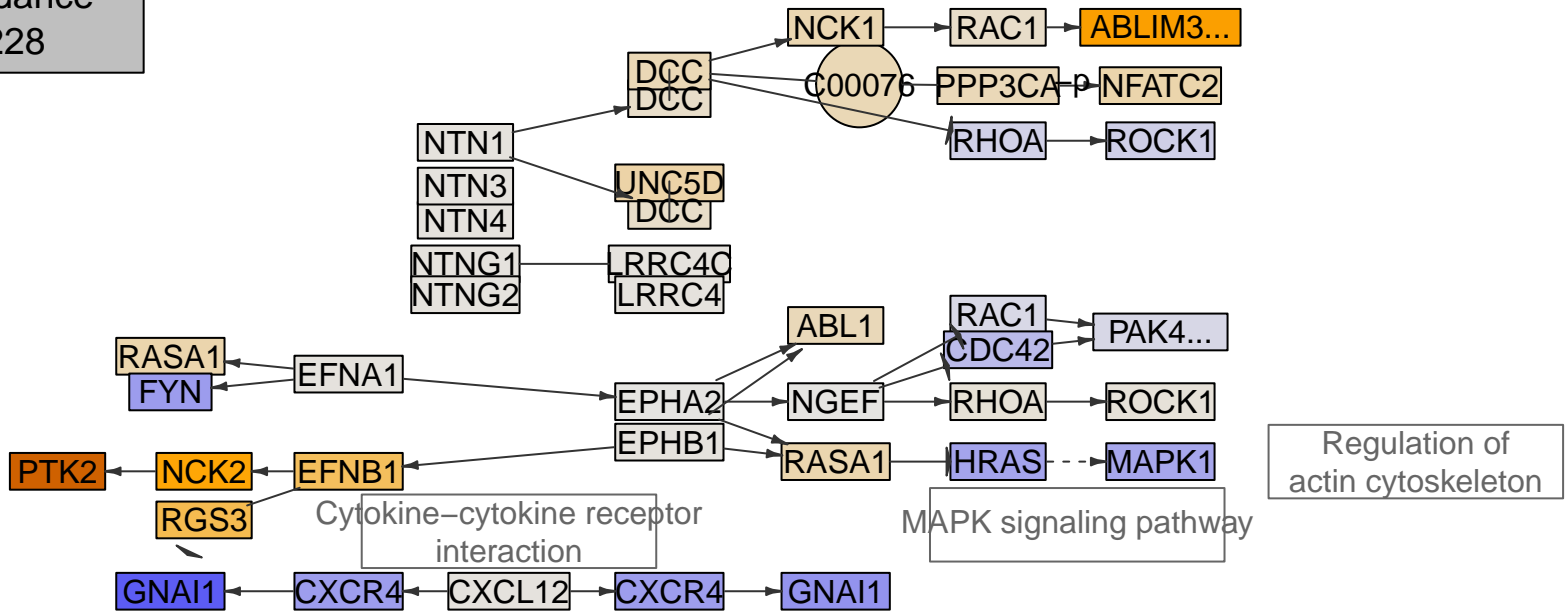

Regulation of actin cytoskeleton

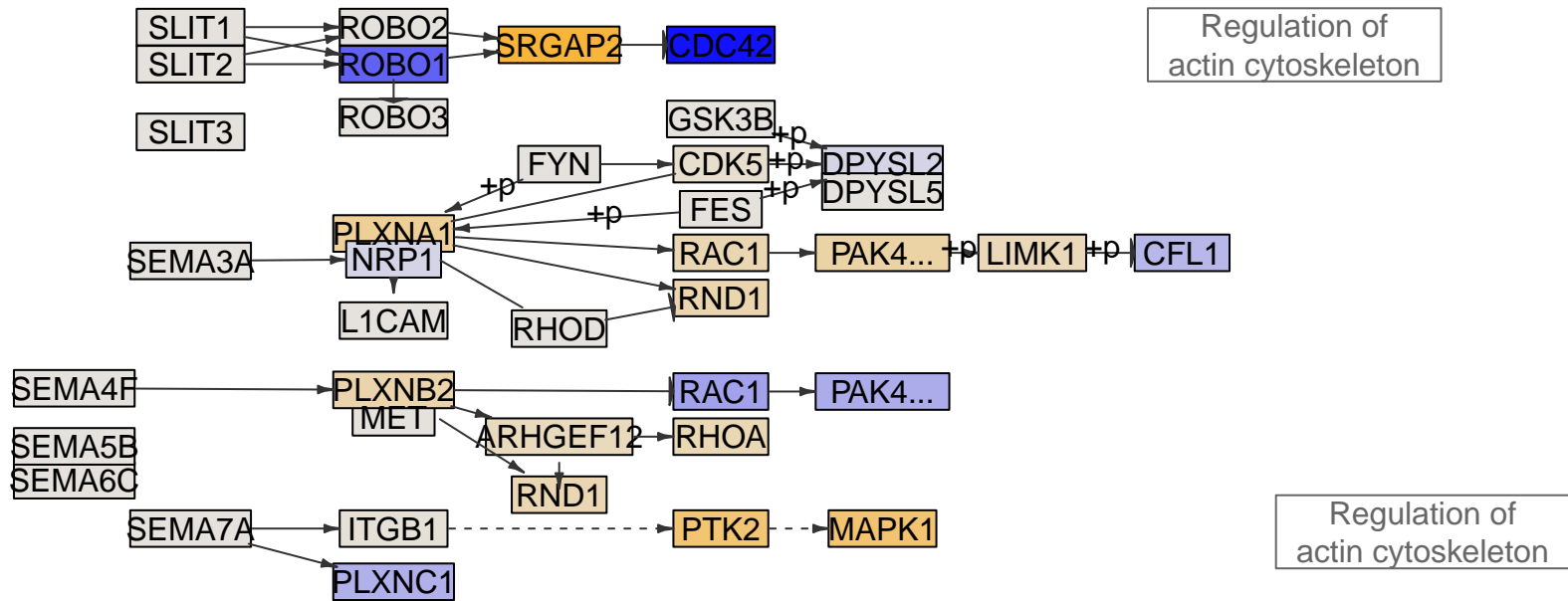

Regulation of actin cytoskeleton

Regulation of actin cytoskeleton

Axon guidance
MPI-229

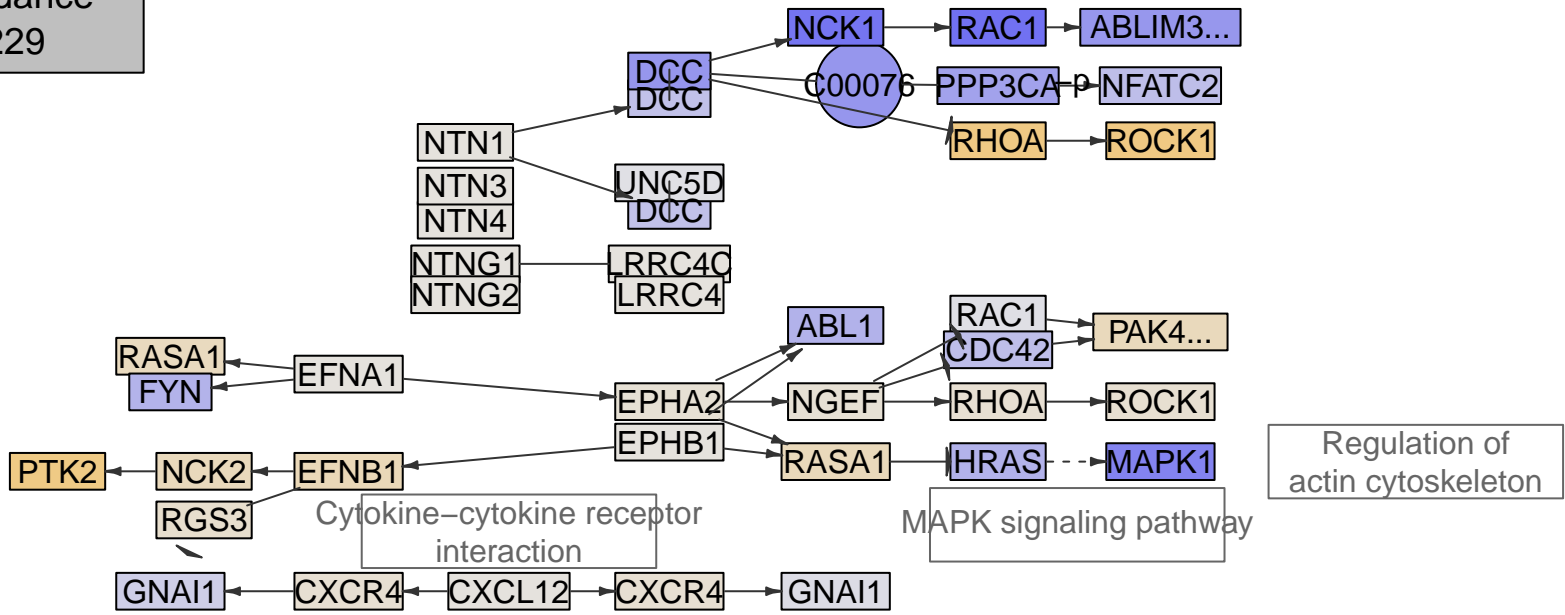

Regulation of actin cytoskeleton

MAPK signaling pathway

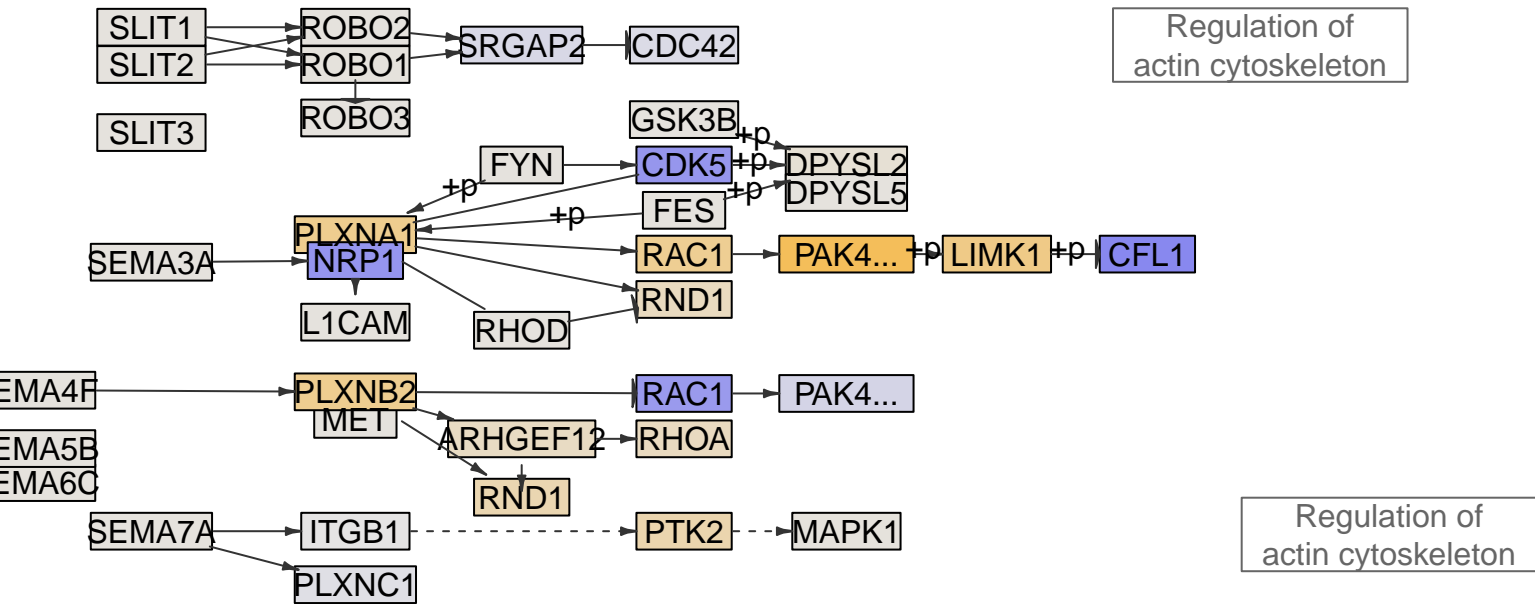

Regulation of actin cytoskeleton

Regulation of actin cytoskeleton

Axon guidance
MPI-230

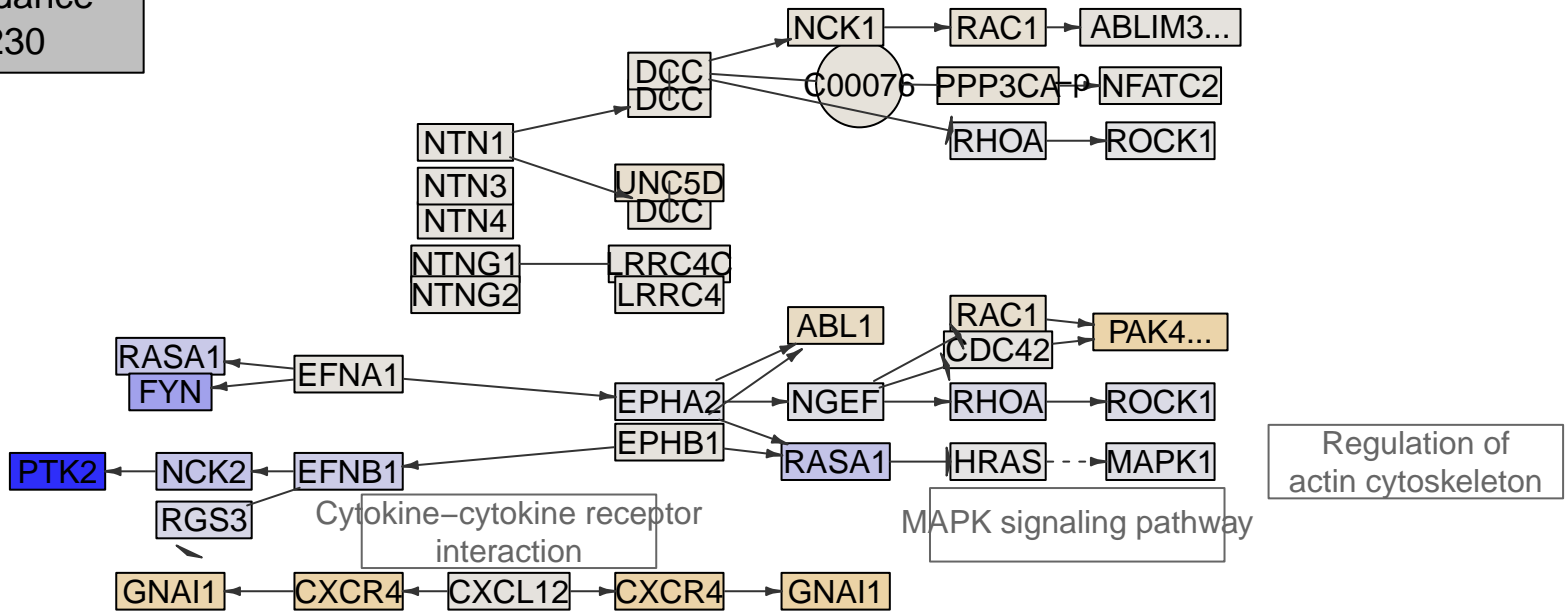

Regulation of actin cytoskeleton

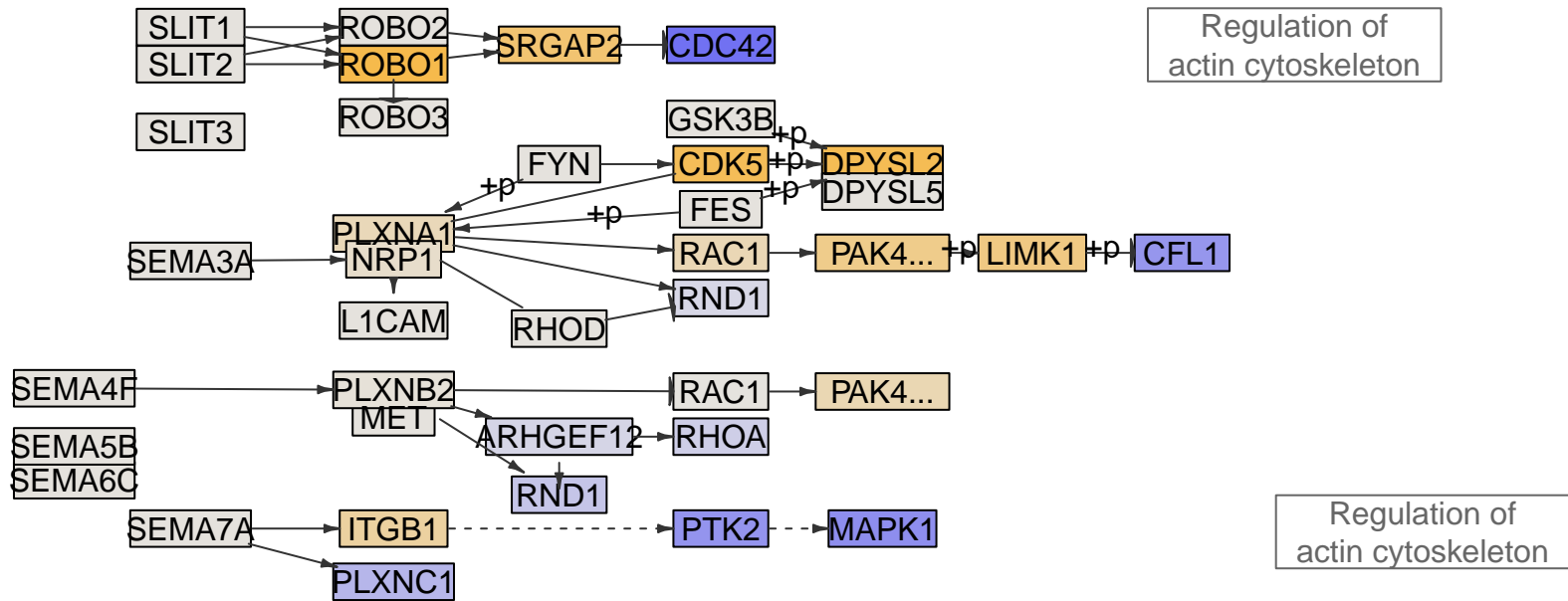

Regulation of actin cytoskeleton

Regulation of actin cytoskeleton

Axon guidance
MPI-231

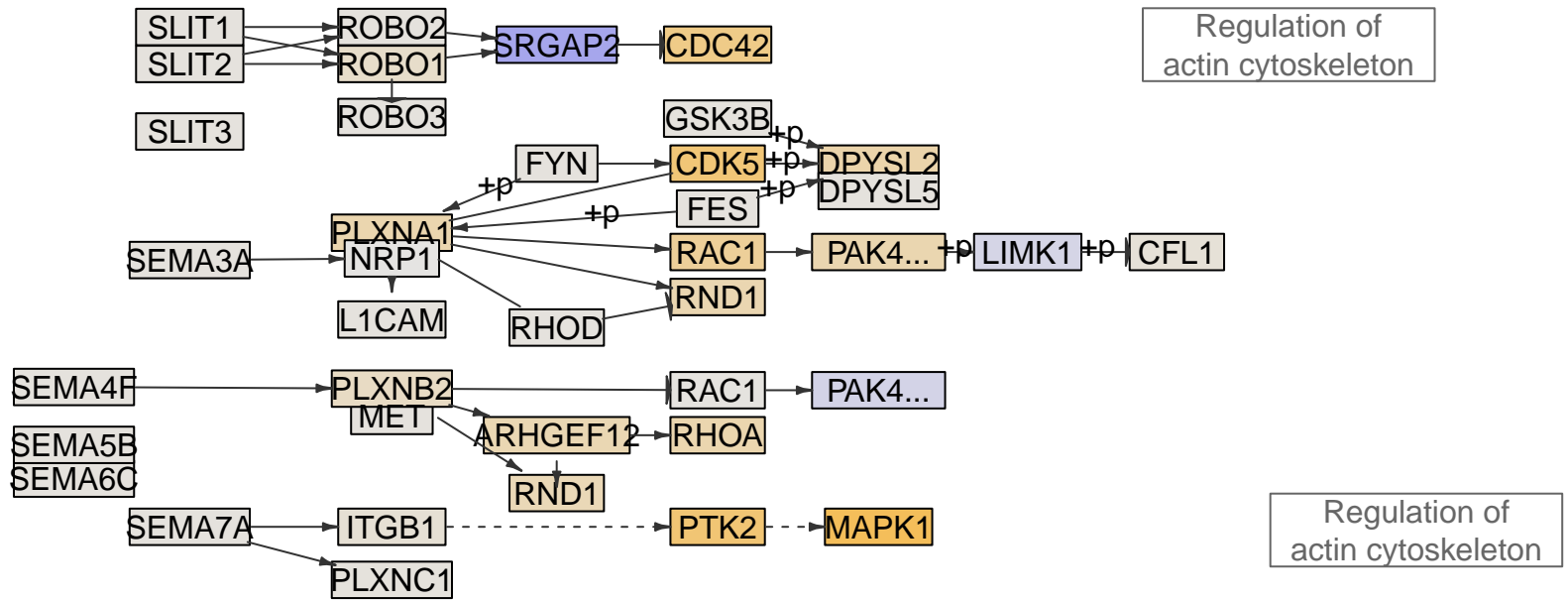
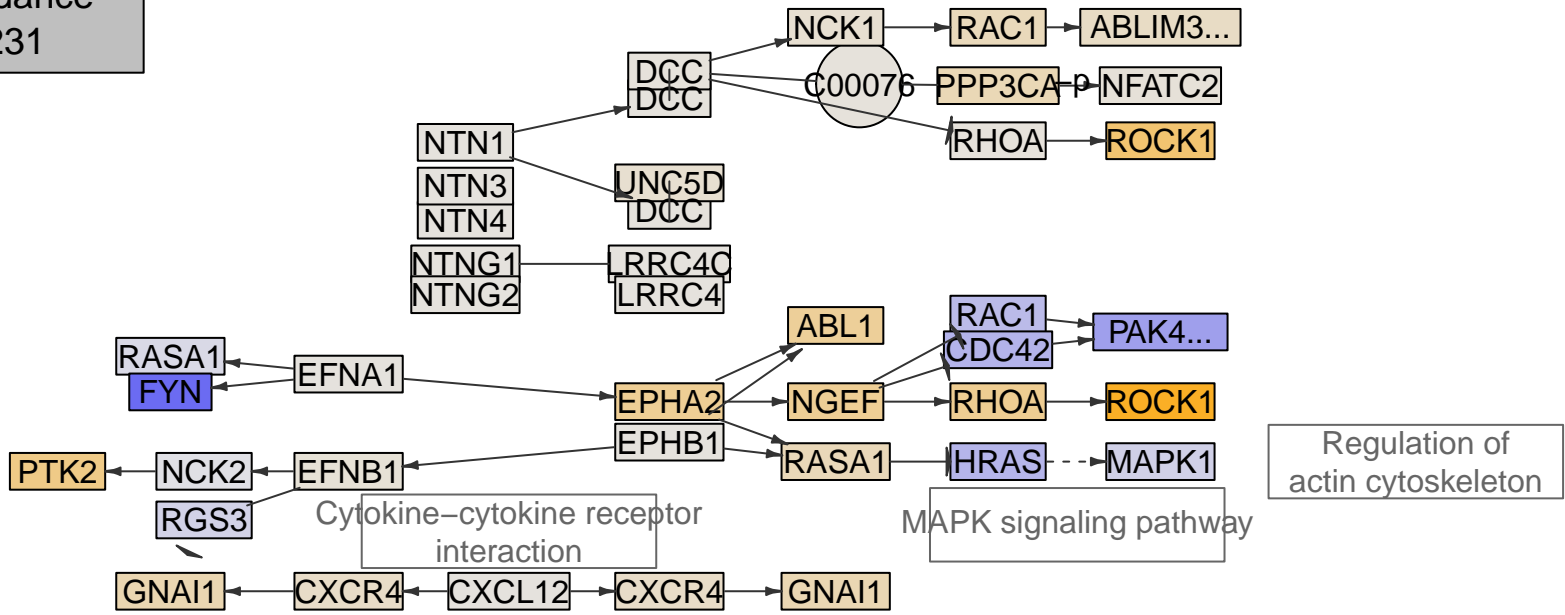

Axon guidance
MPI-232

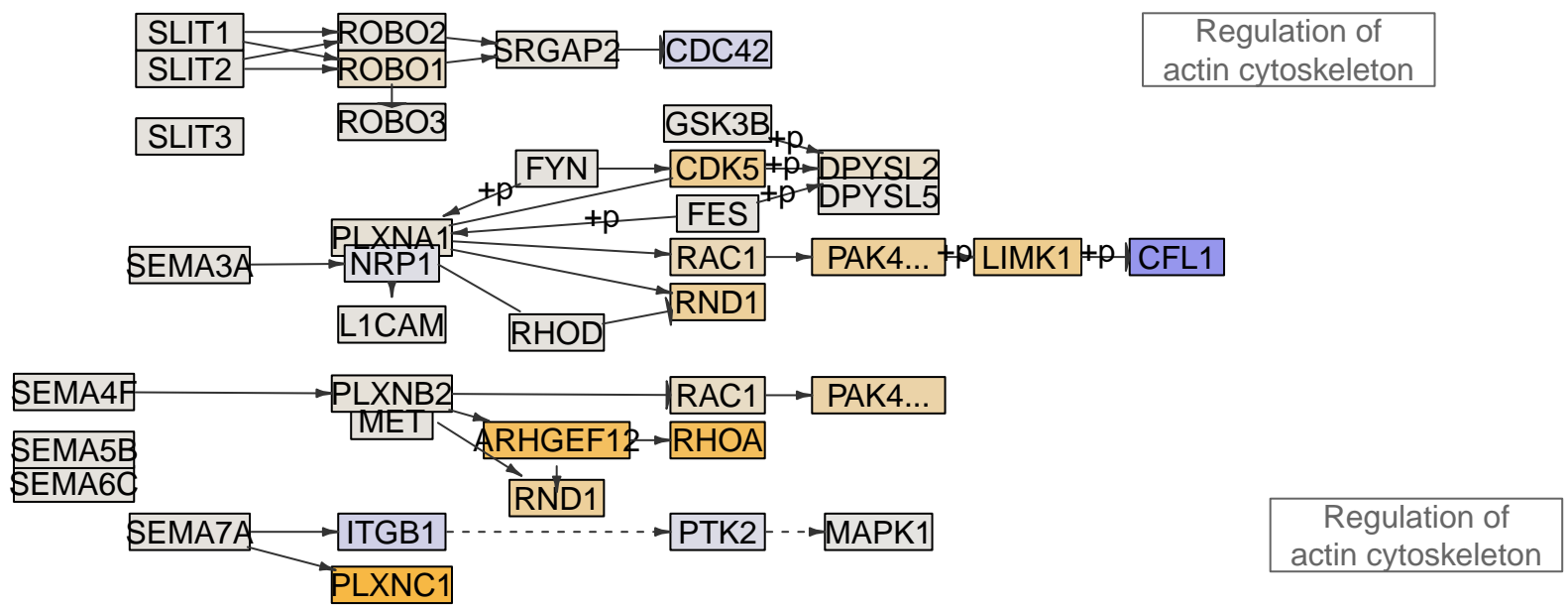
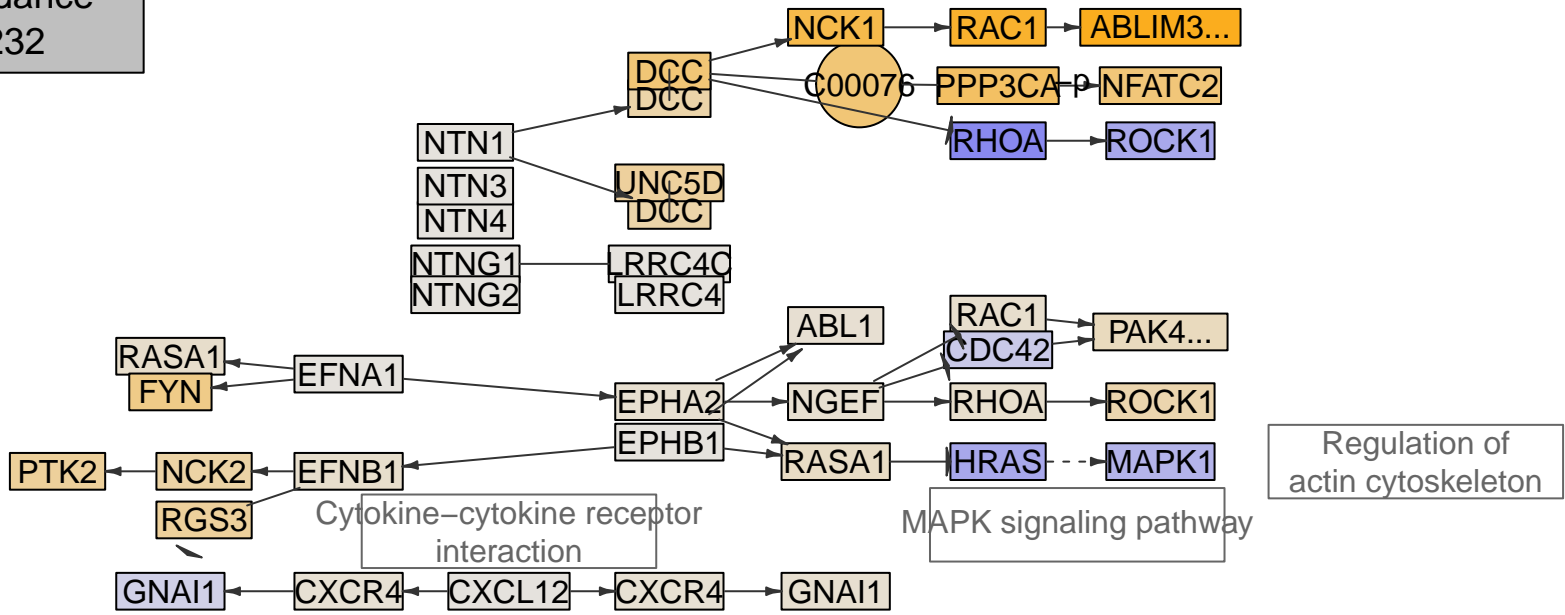

Axon guidance
MPI-233

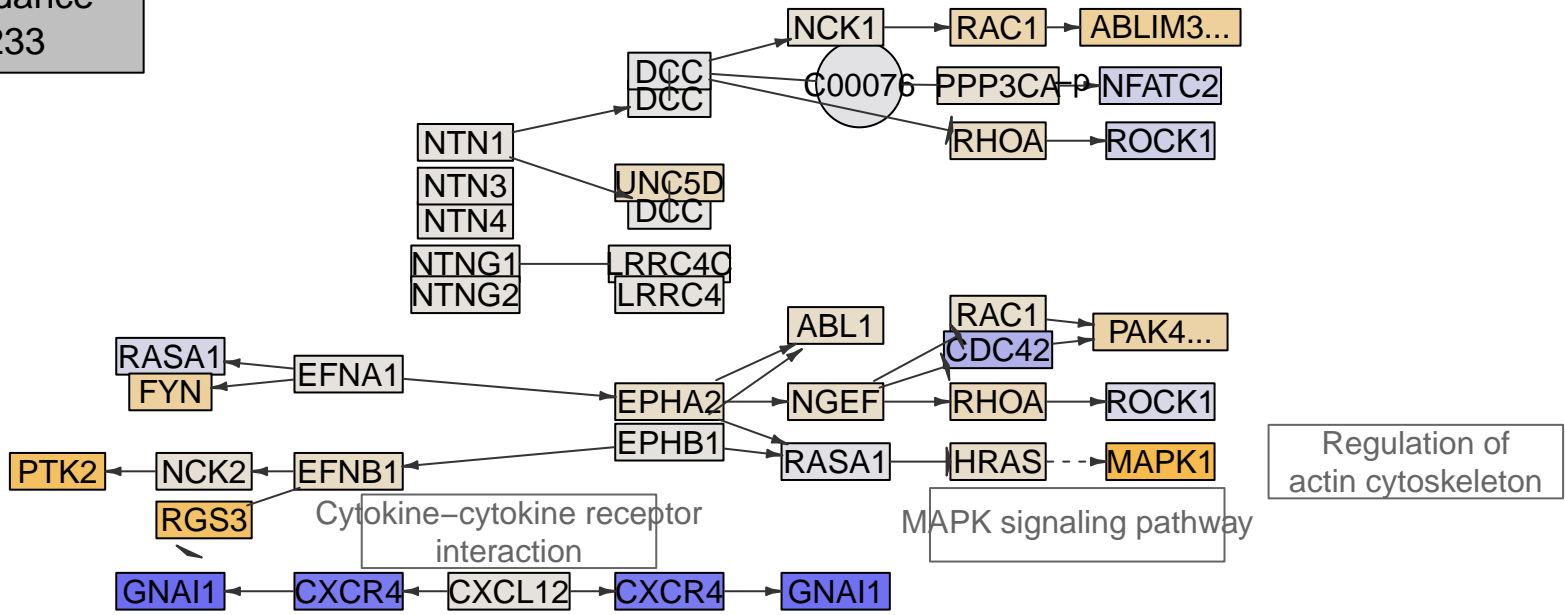

Regulation of actin cytoskeleton

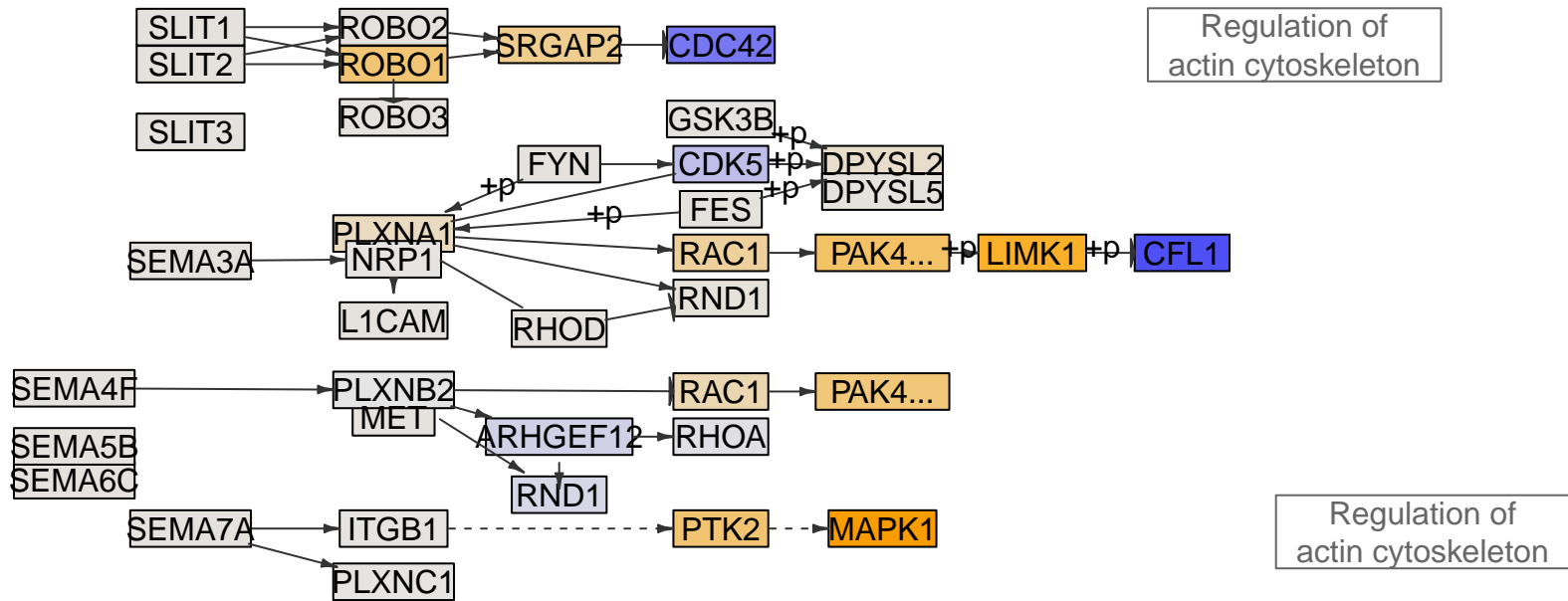

Regulation of actin cytoskeleton

Regulation of actin cytoskeleton

Axon guidance
MPI-234

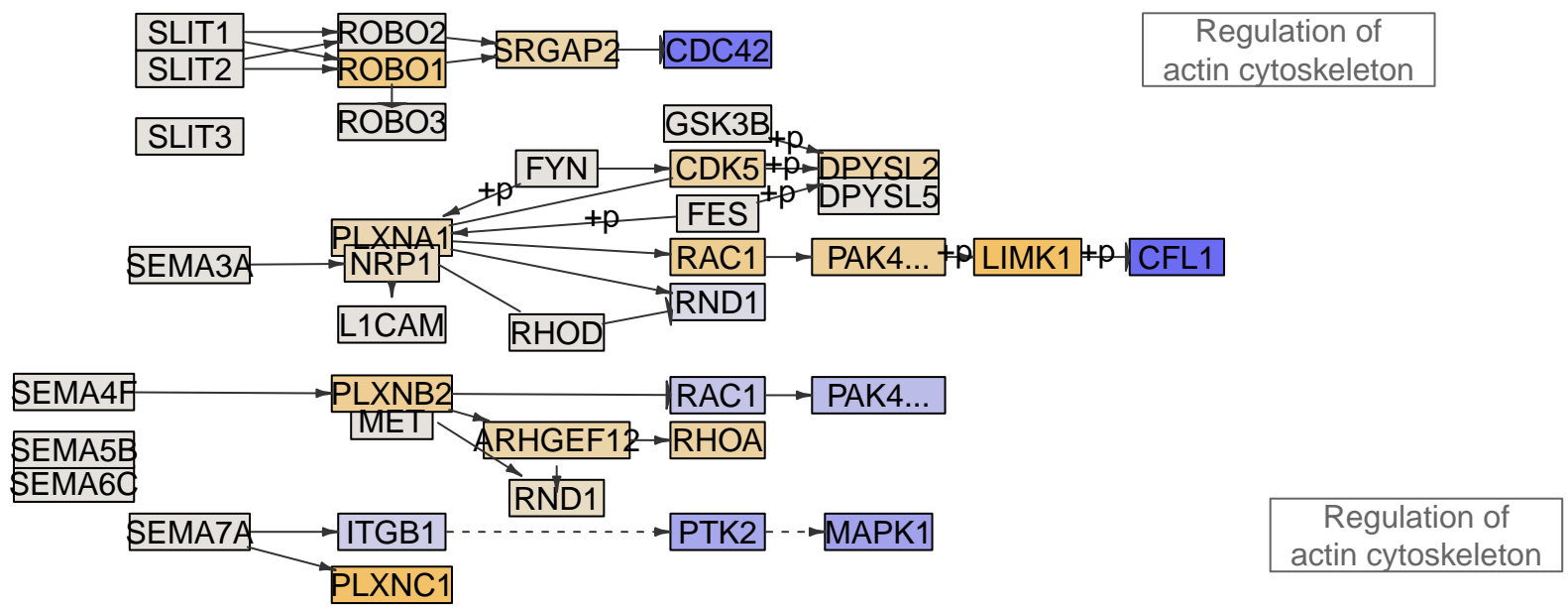
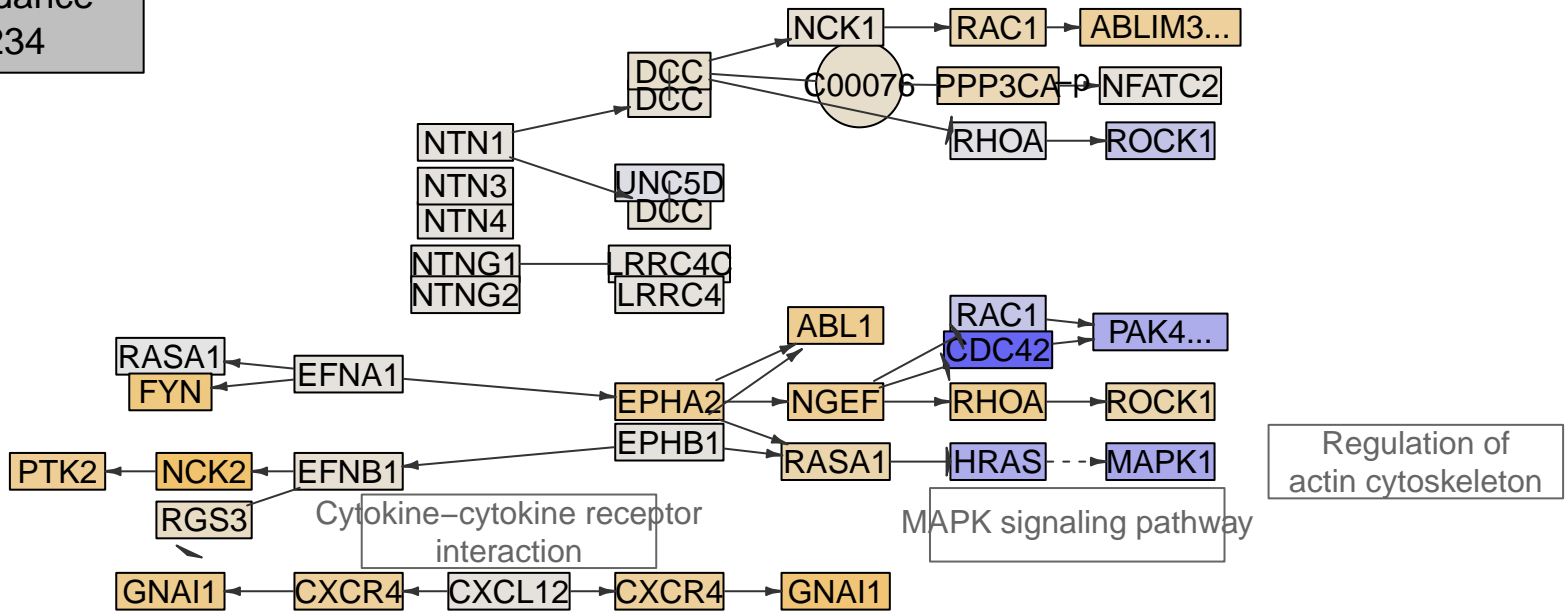

Axon guidance
MPI-235

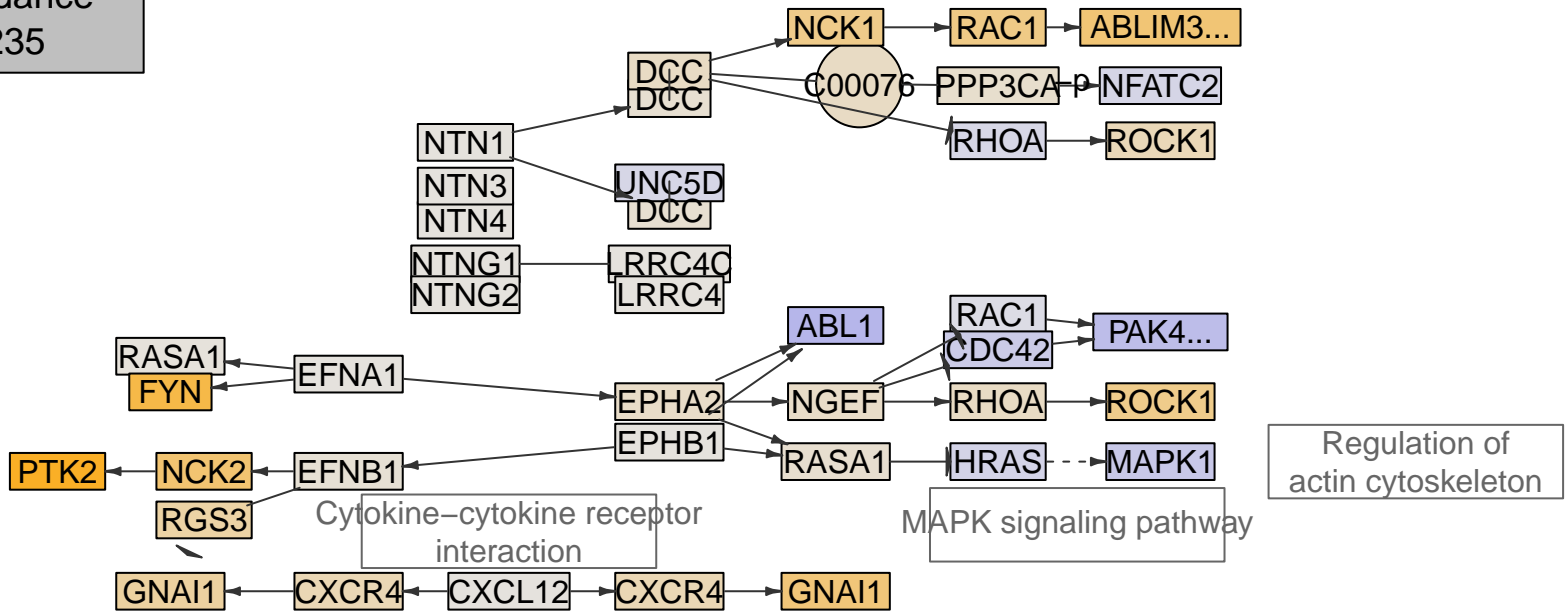

Regulation of actin cytoskeleton

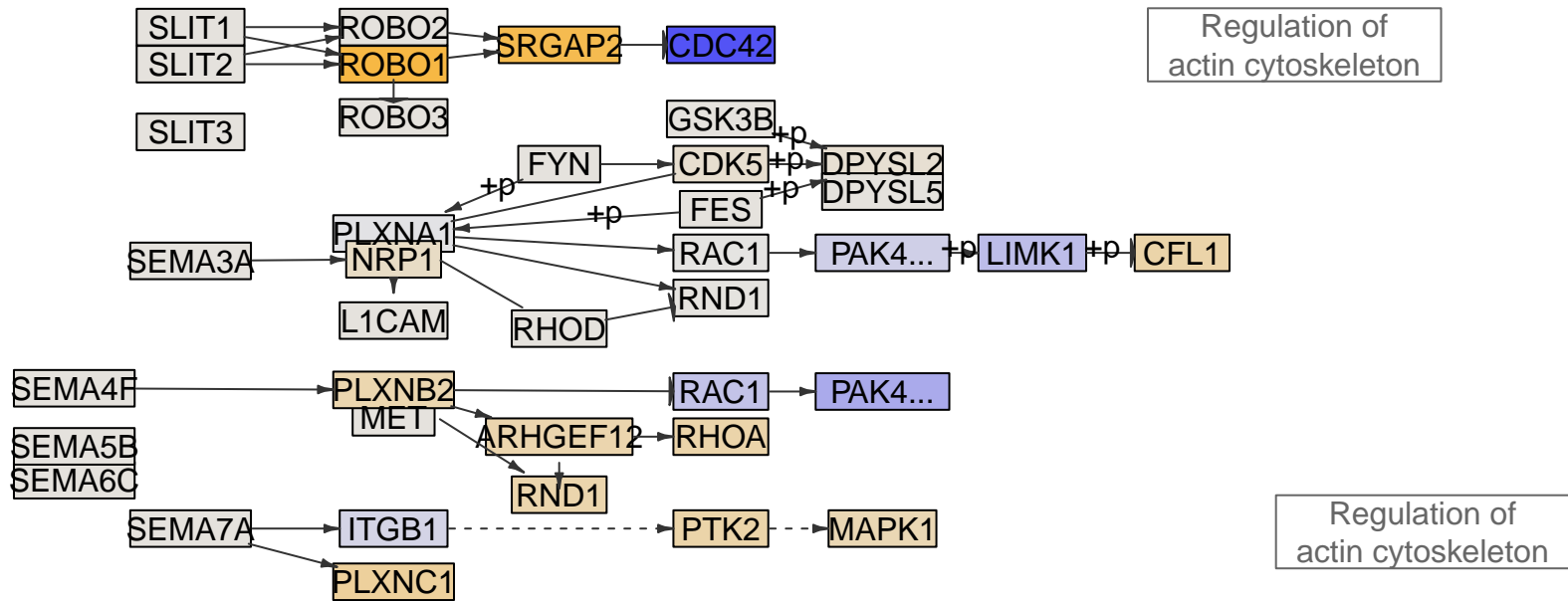

Regulation of actin cytoskeleton

Regulation of actin cytoskeleton

Axon guidance
MPI-236

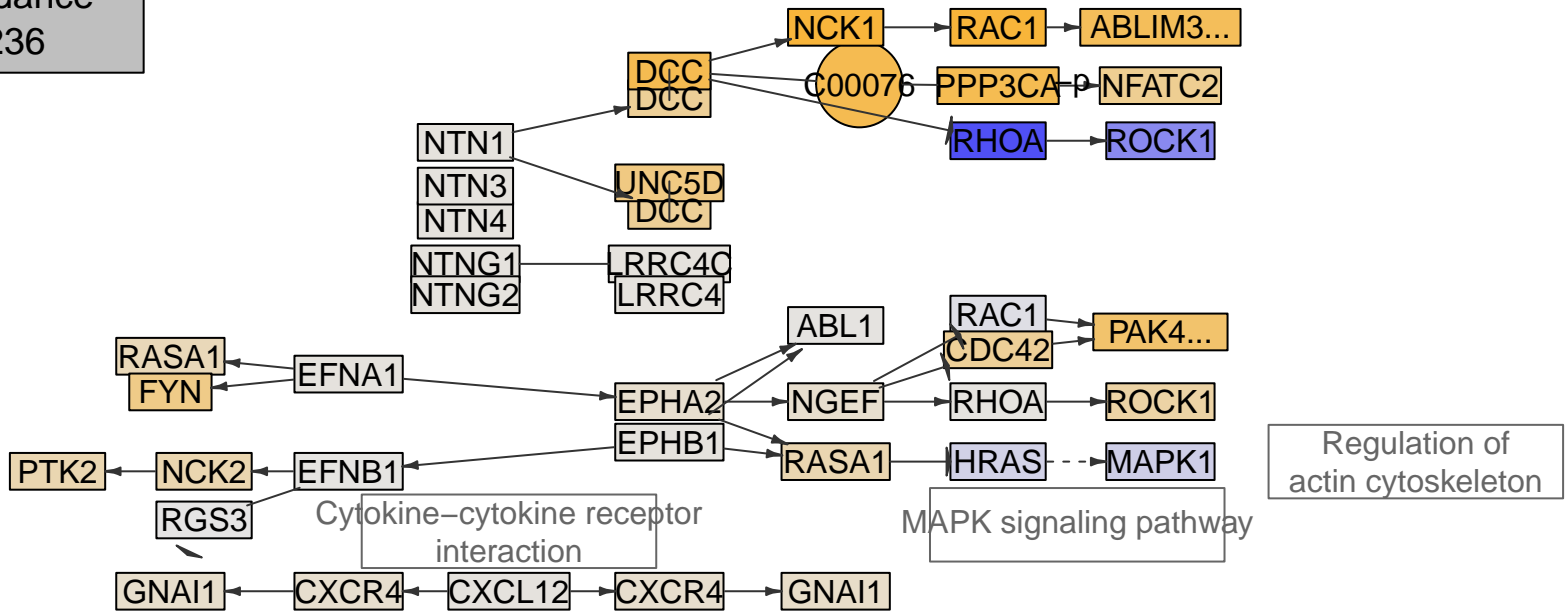

Regulation of actin cytoskeleton

MAPK signaling pathway

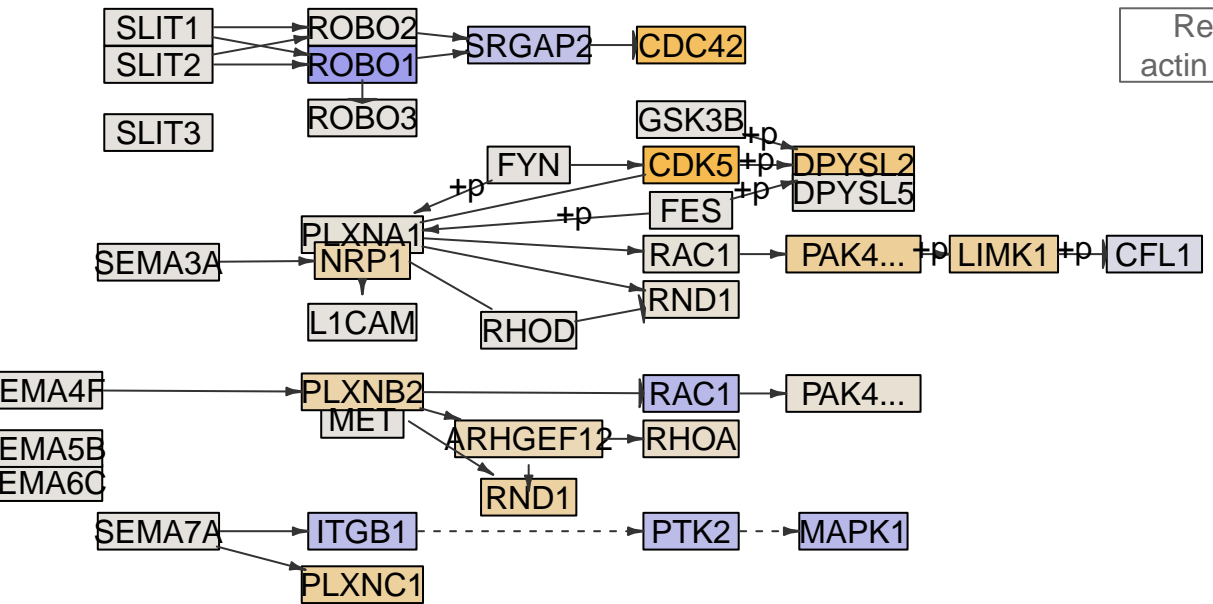

Regulation of actin cytoskeleton

Regulation of actin cytoskeleton

Axon guidance
MPI-237

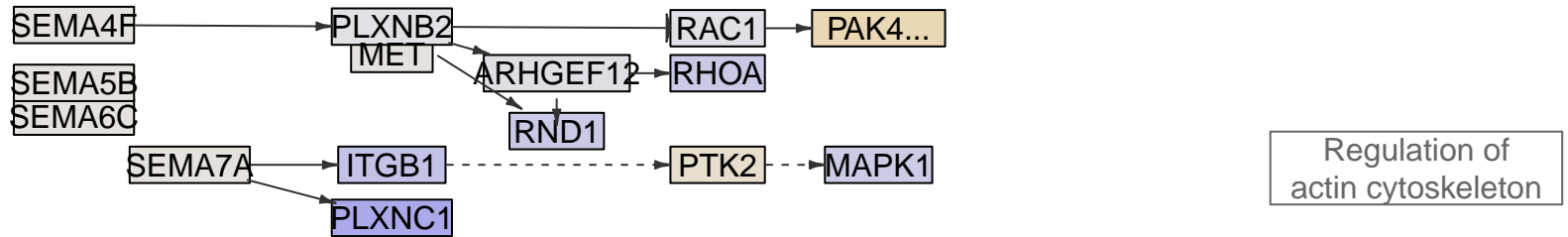
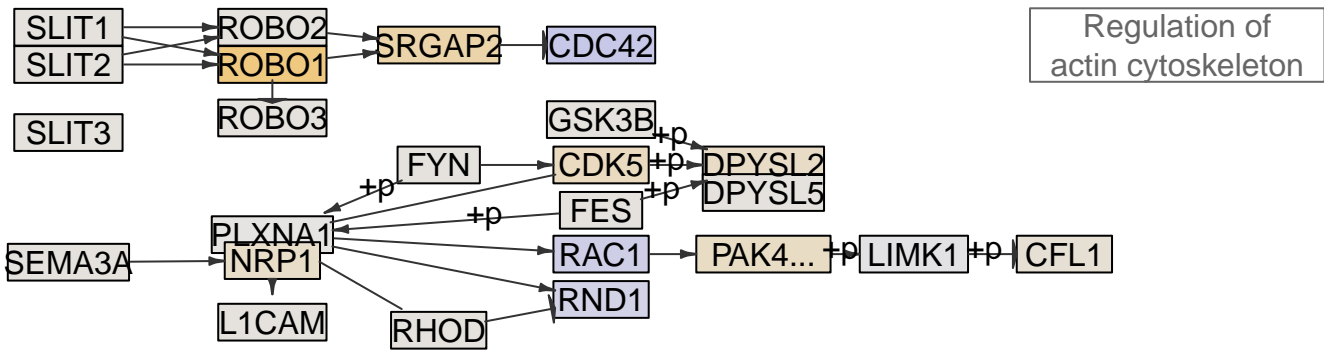
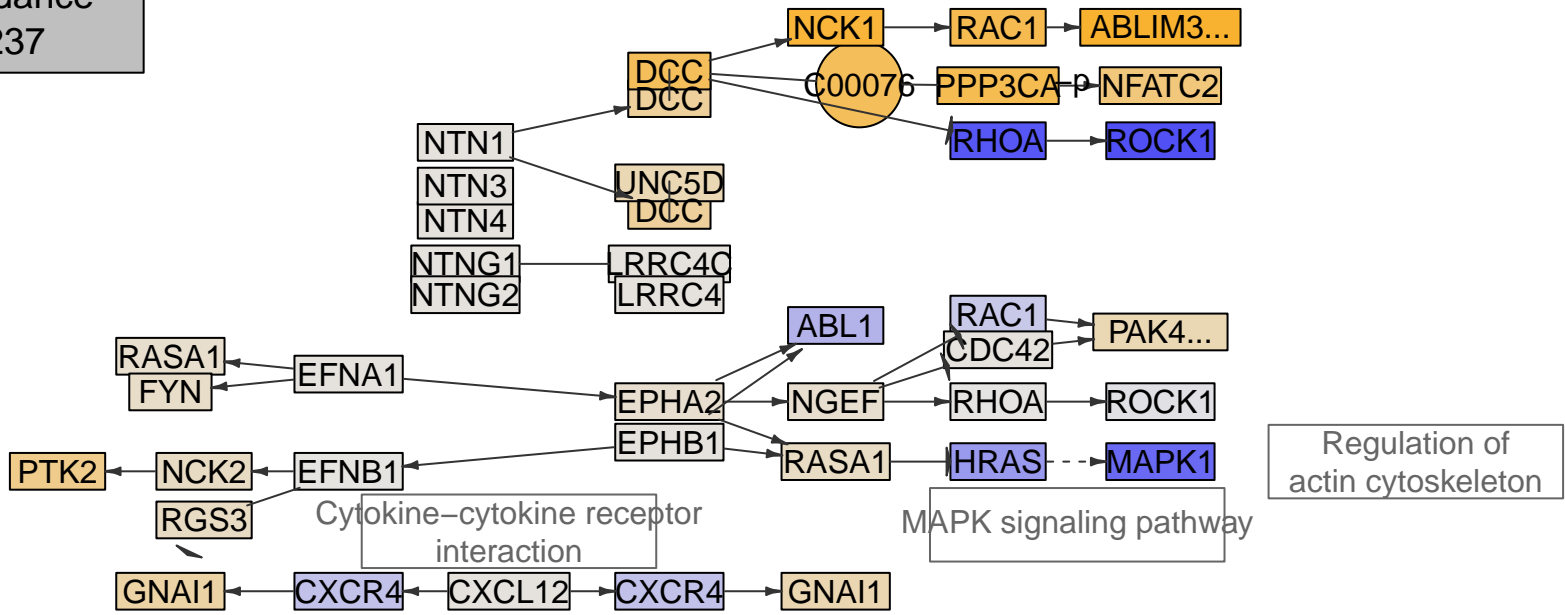

Regulation of actin cytoskeleton

Axon guidance
MPI-239

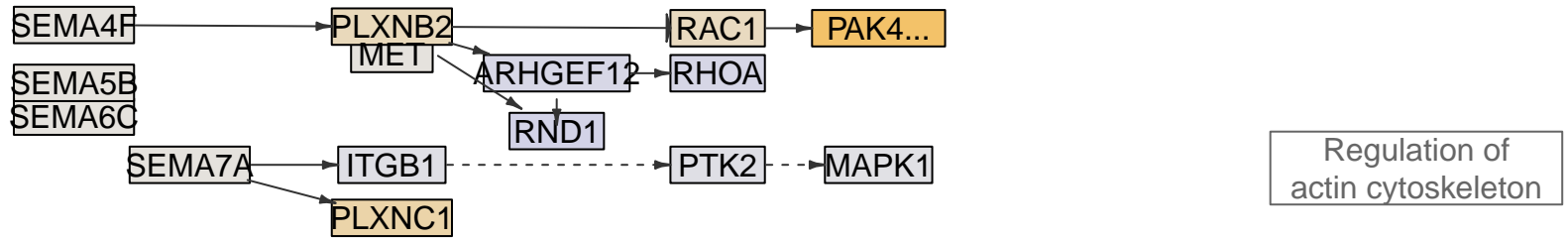
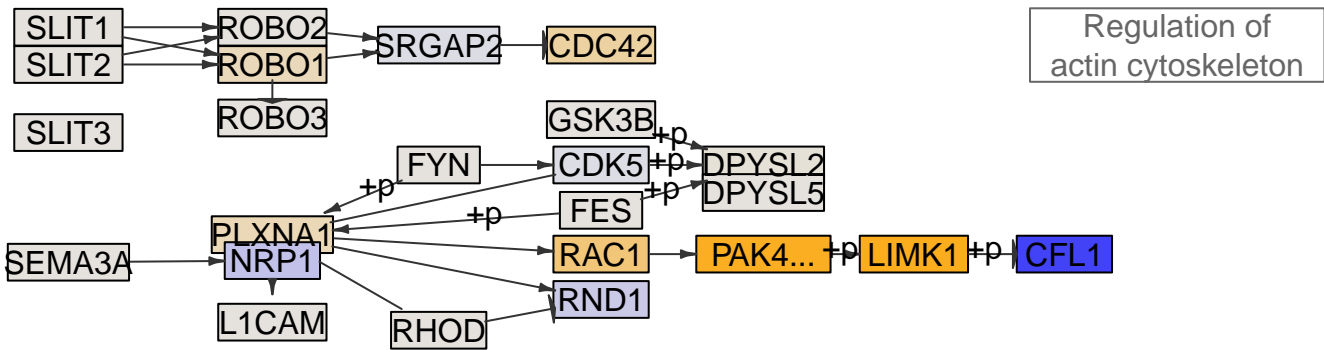
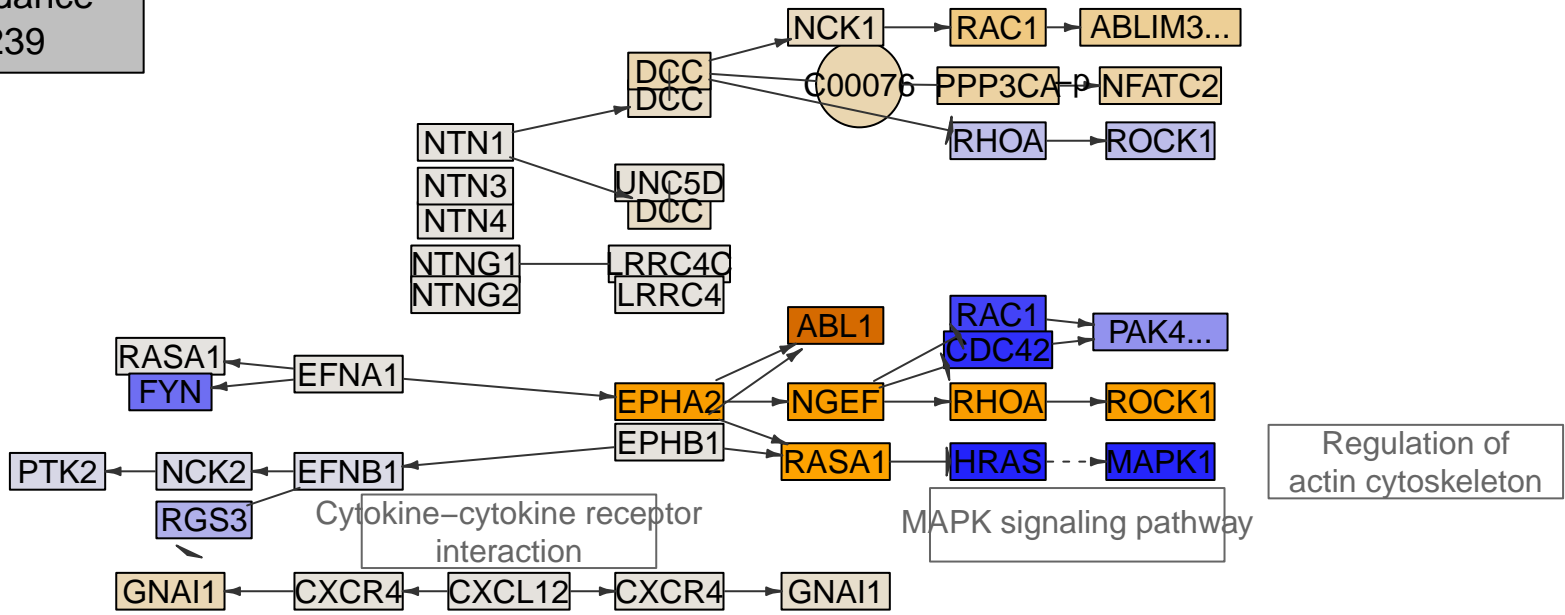

Axon guidance
MPI-241

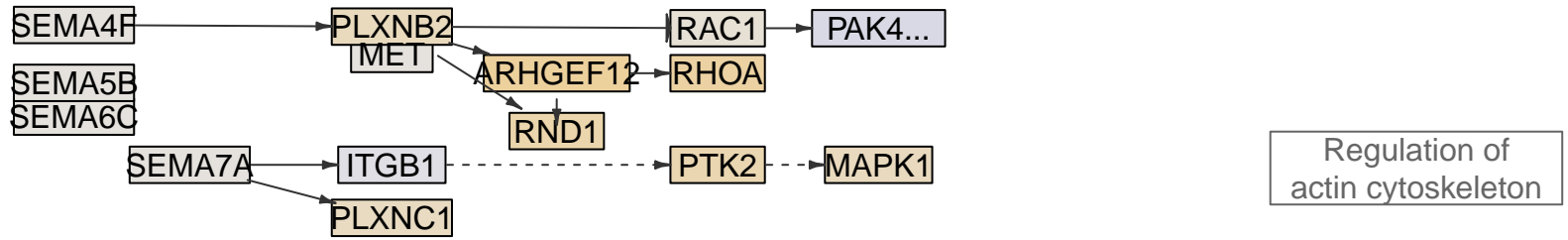
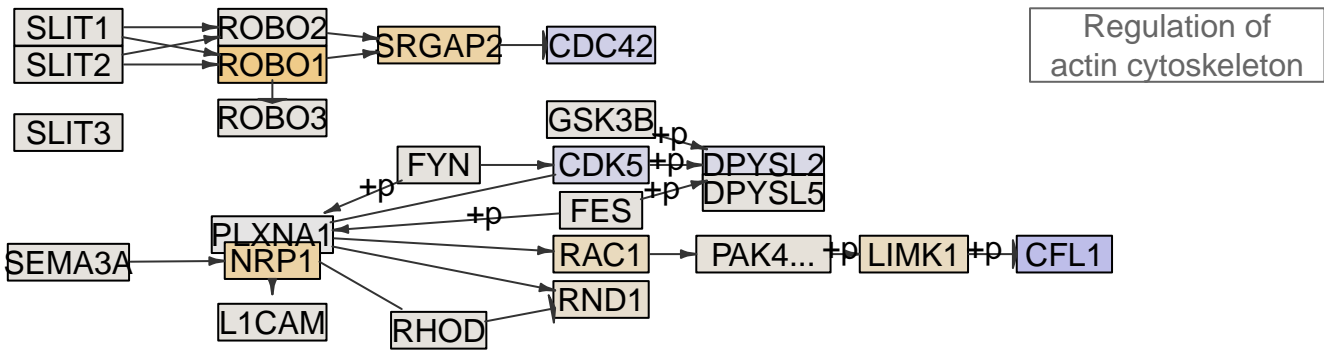
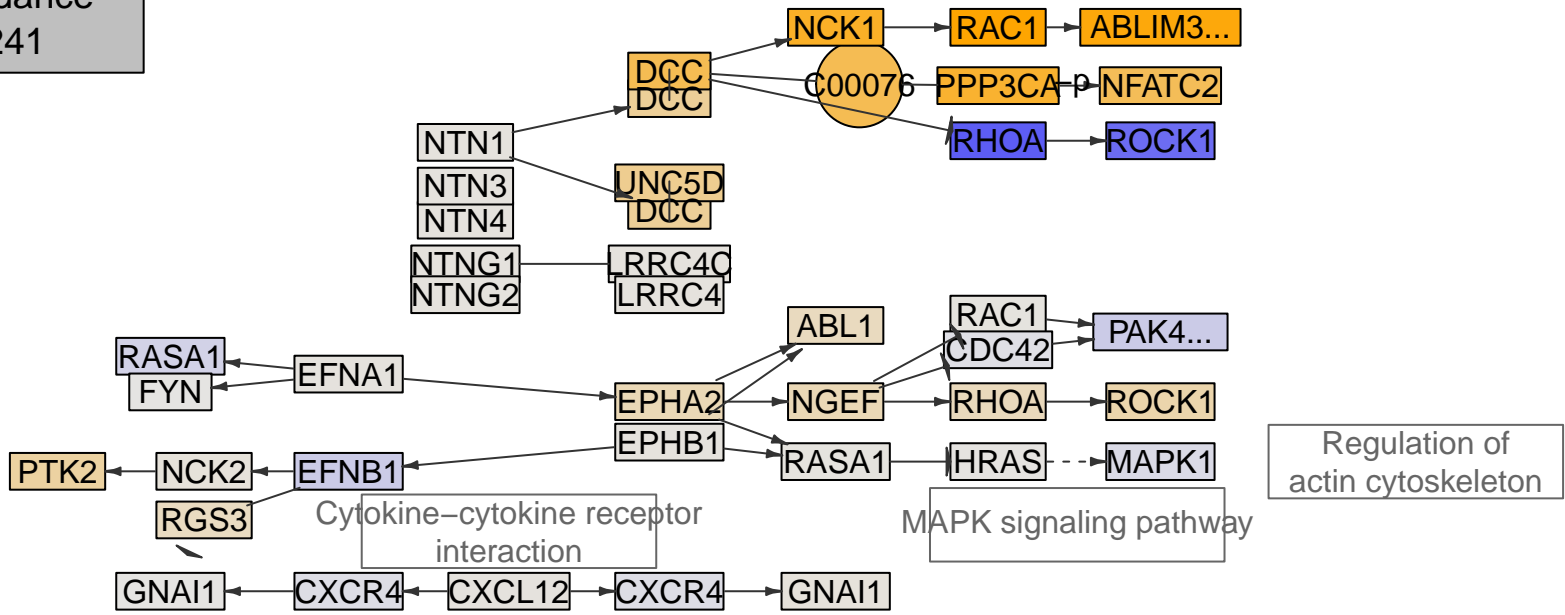

Axon guidance
MPI-243

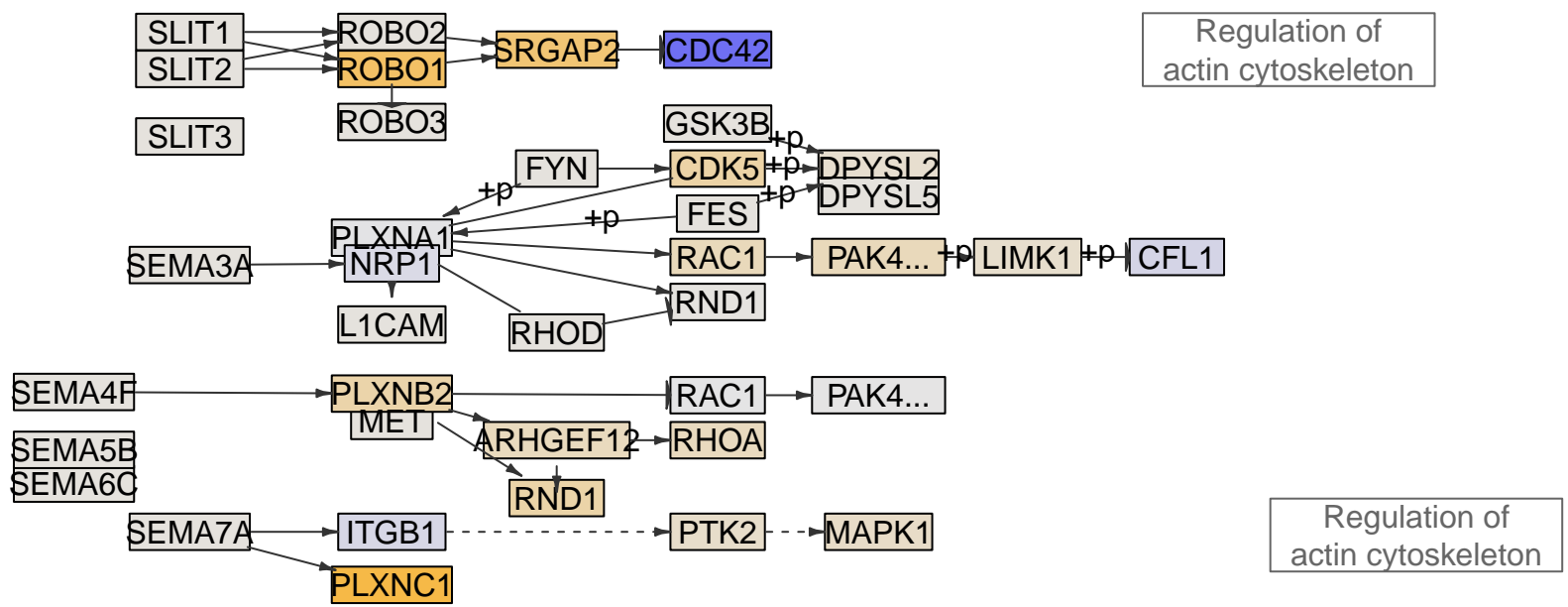
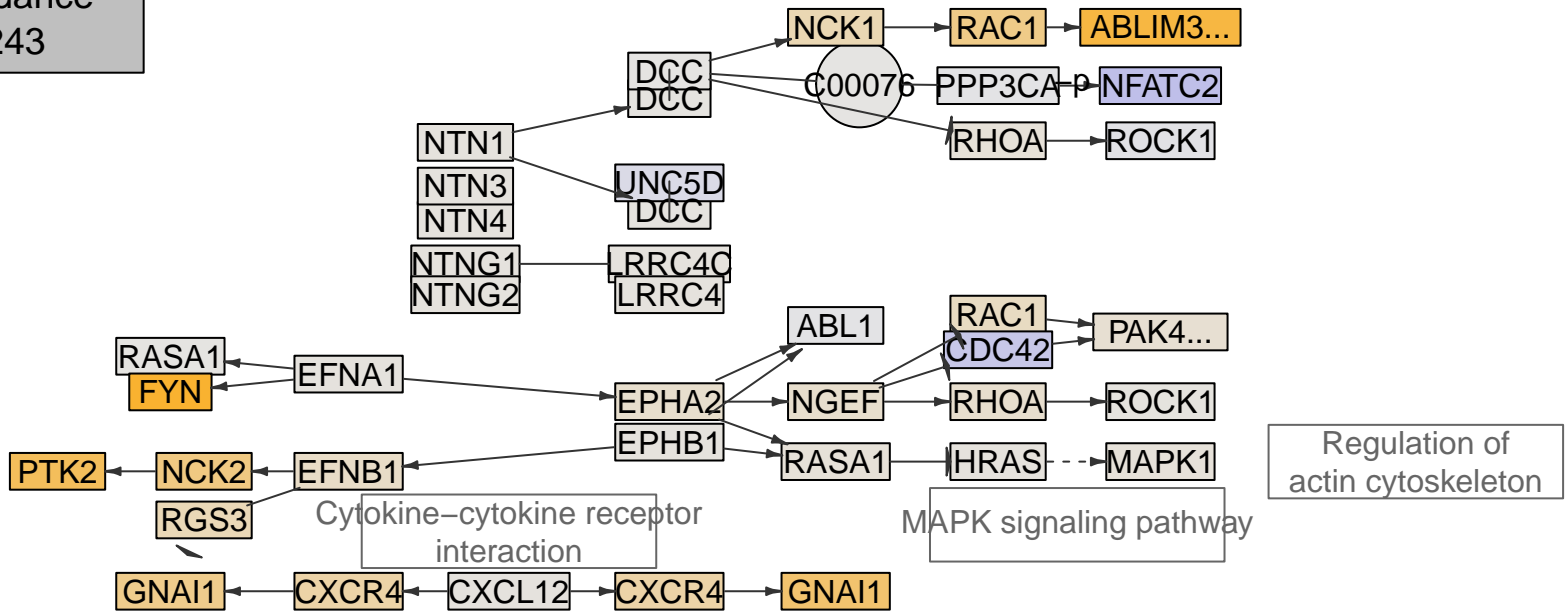

Axon guidance
MPI-244

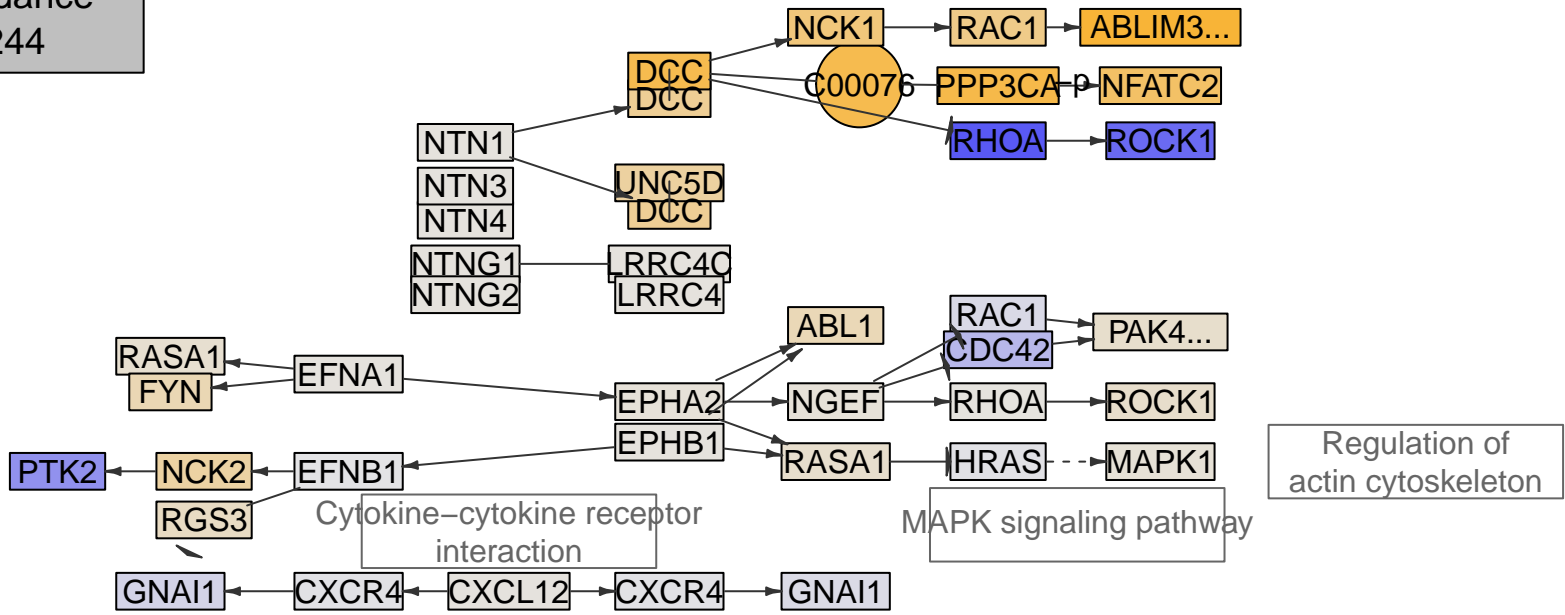

Regulation of actin cytoskeleton

MAPK signaling pathway

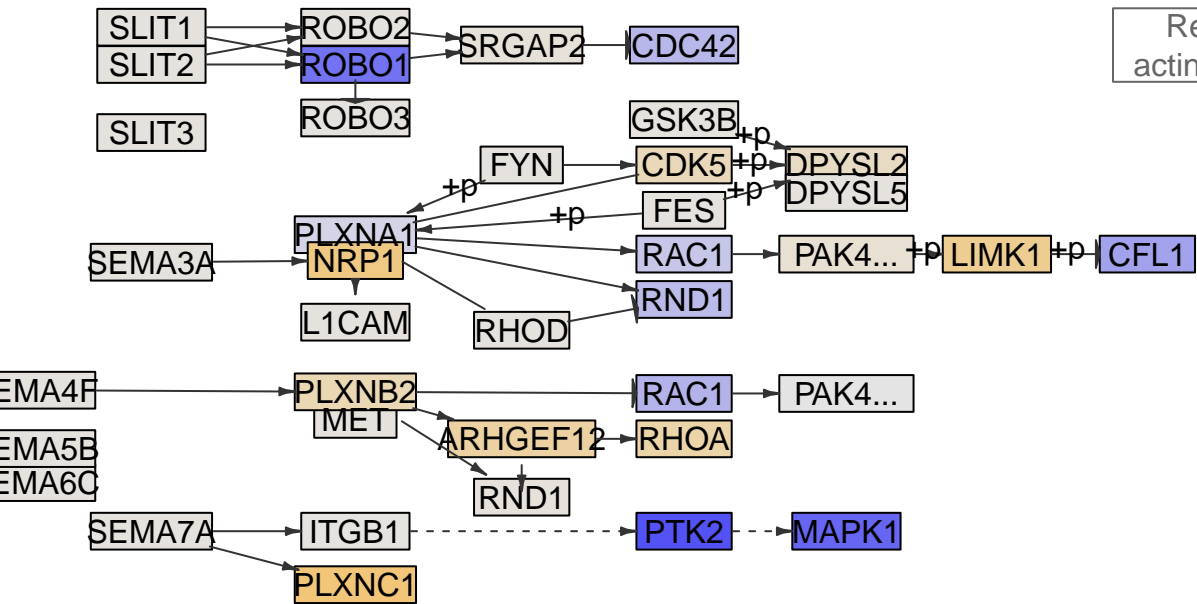

Regulation of actin cytoskeleton

Regulation of actin cytoskeleton

Axon guidance
MPI-246

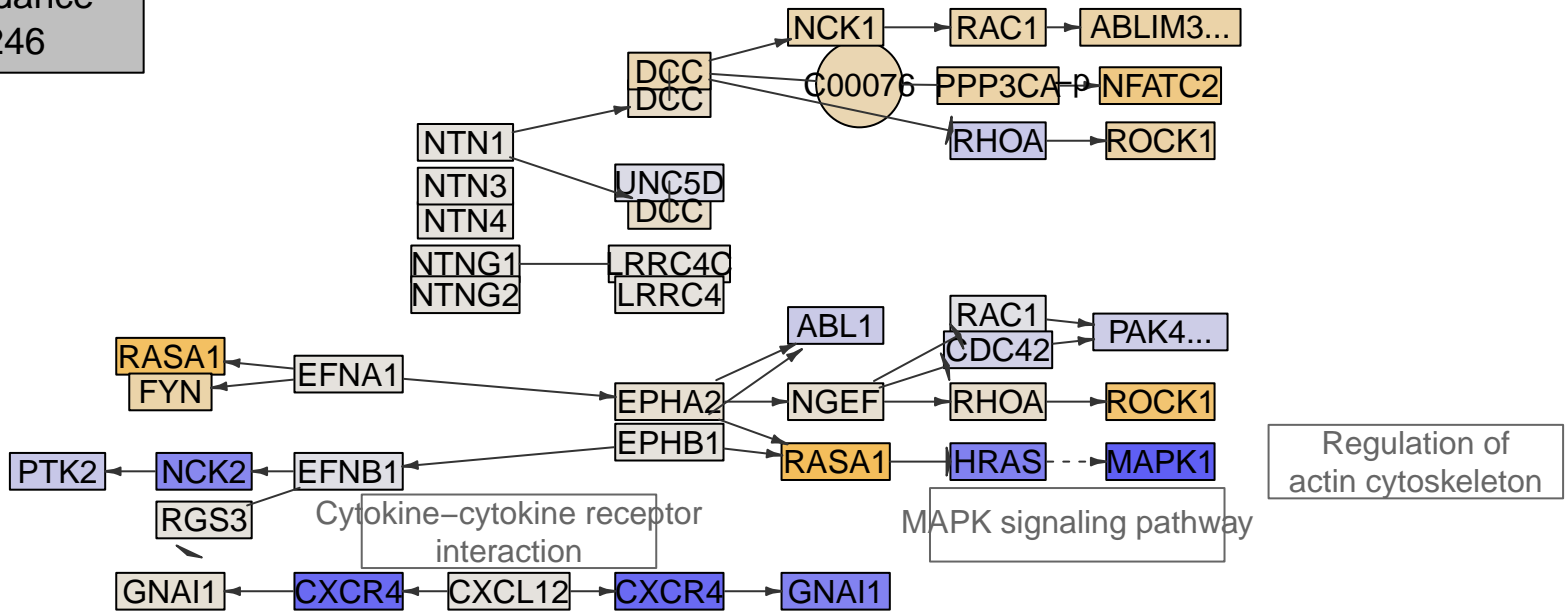

Regulation of actin cytoskeleton

MAPK signaling pathway

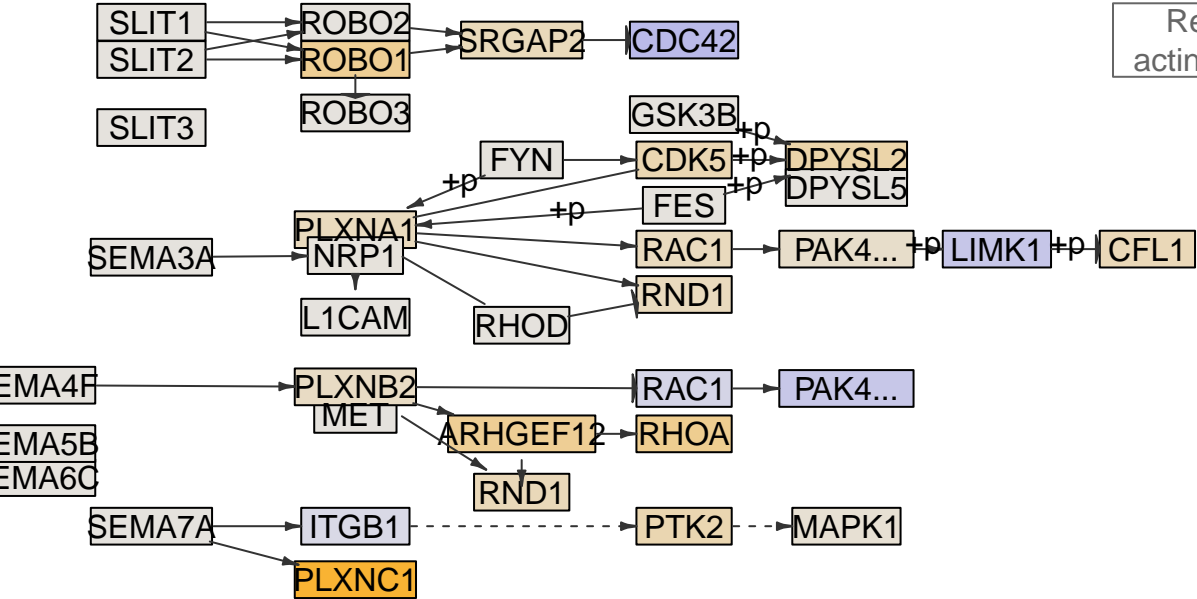

Regulation of actin cytoskeleton

Regulation of actin cytoskeleton

Axon guidance
MPI-247

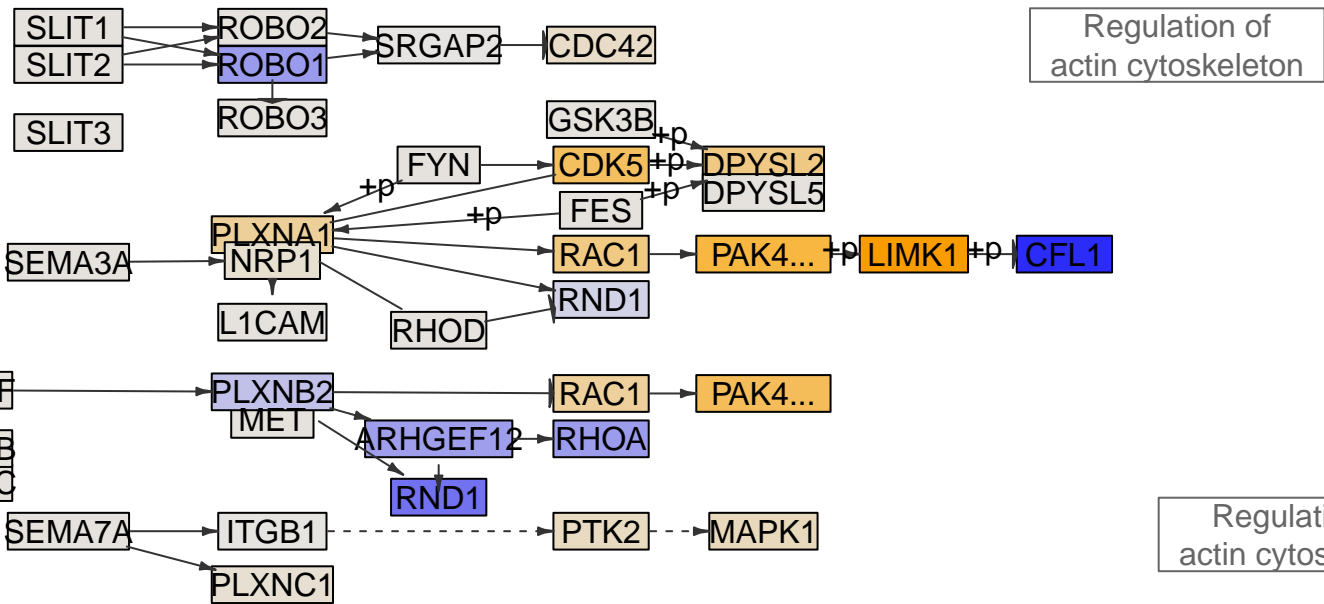
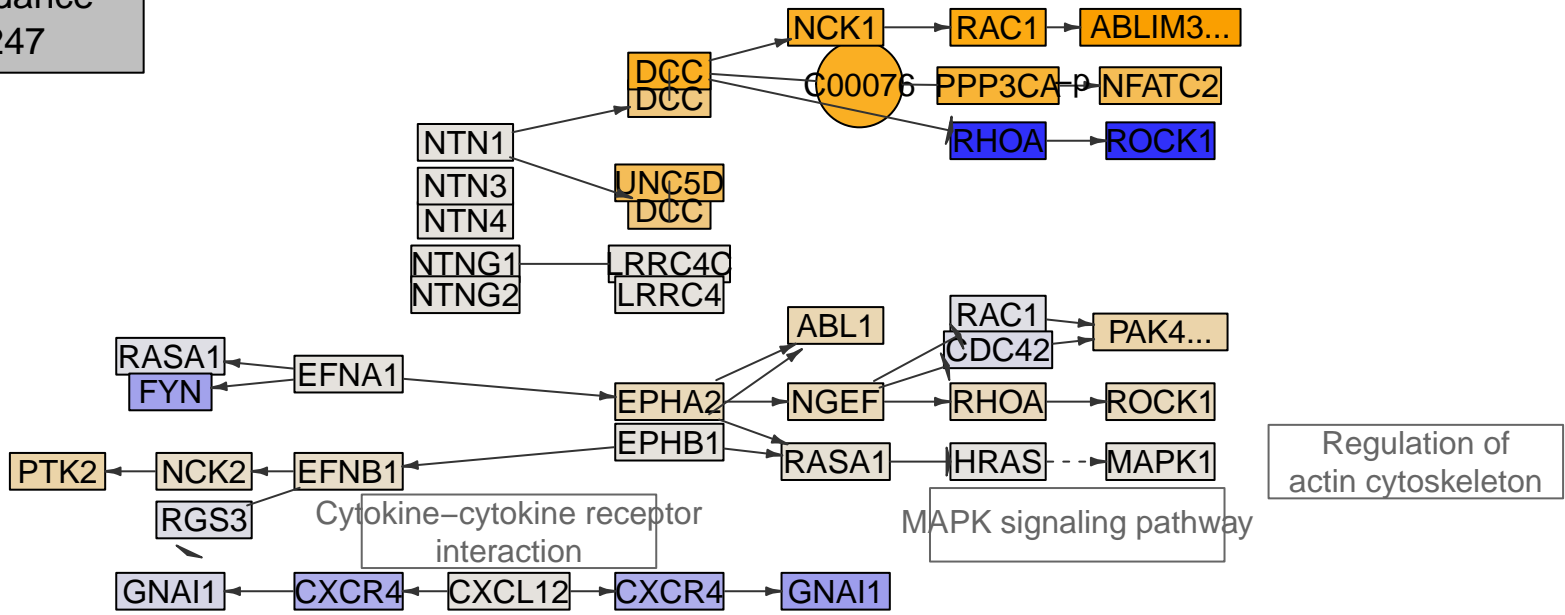

Regulation of actin cytoskeleton

Axon guidance
MPI-251

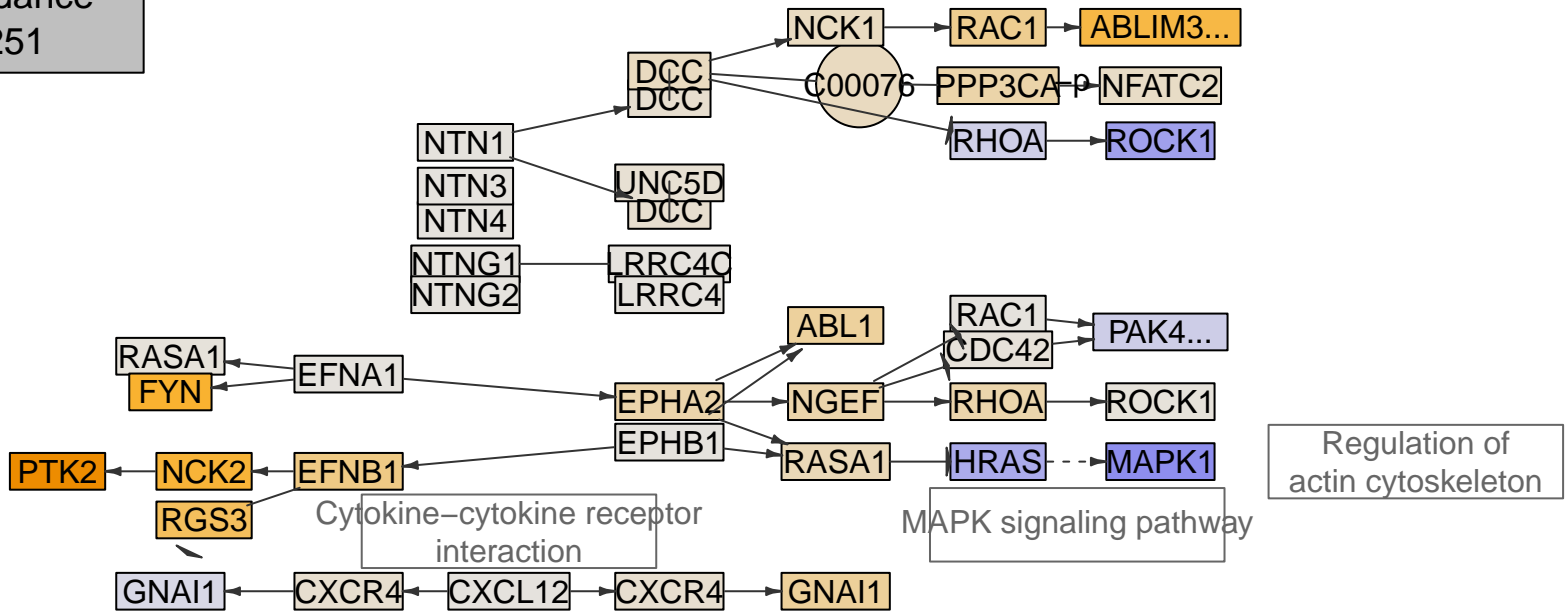

Regulation of actin cytoskeleton

MAPK signaling pathway

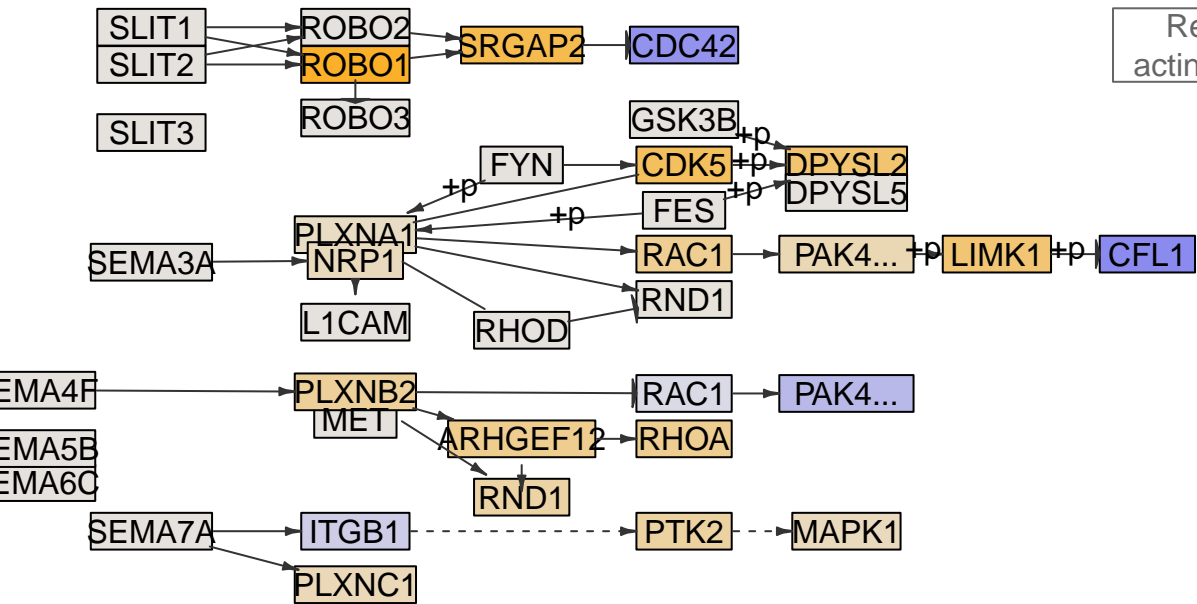

Regulation of actin cytoskeleton

Regulation of actin cytoskeleton

Axon guidance
MPI-255

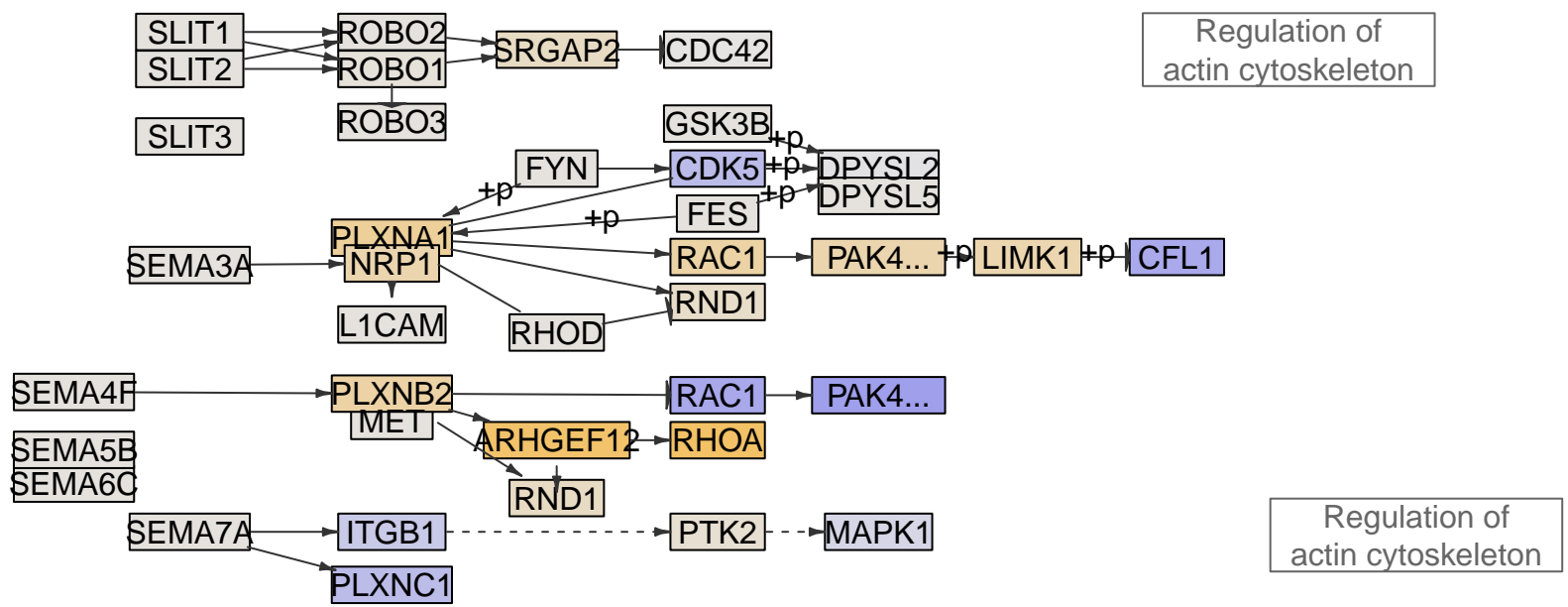
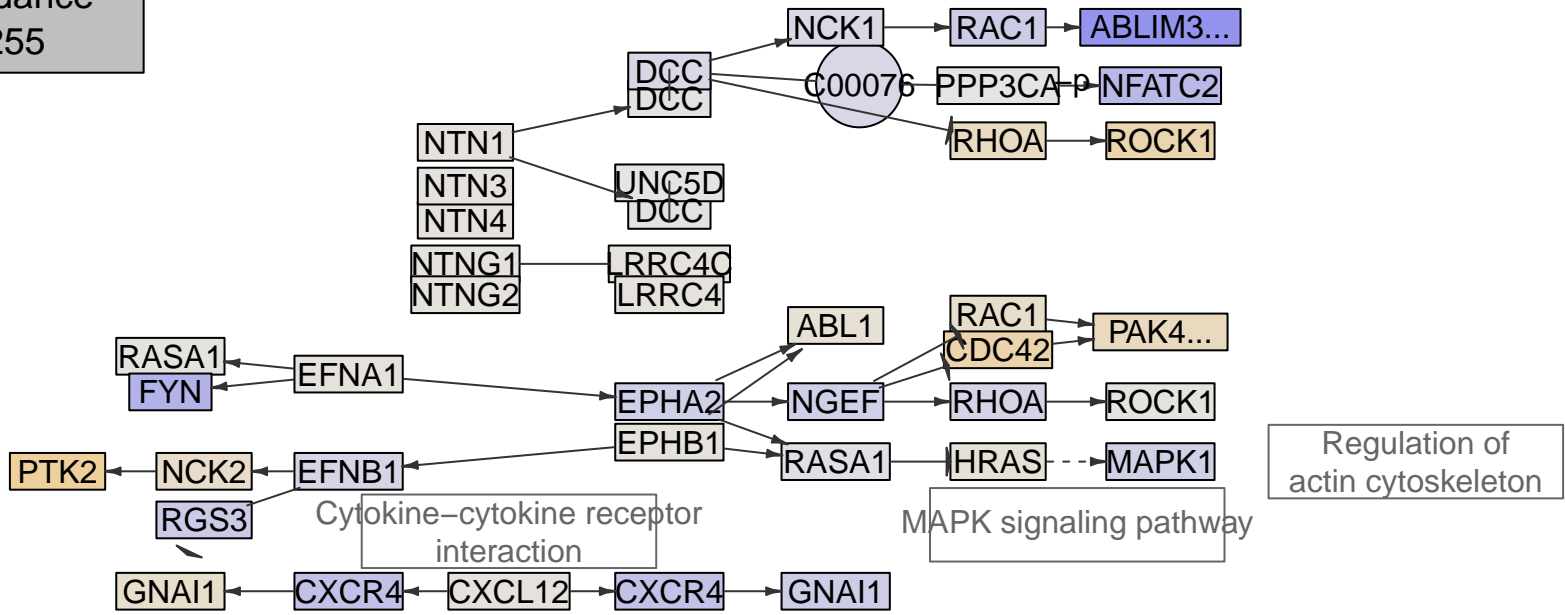

Axon guidance
MPI-223b

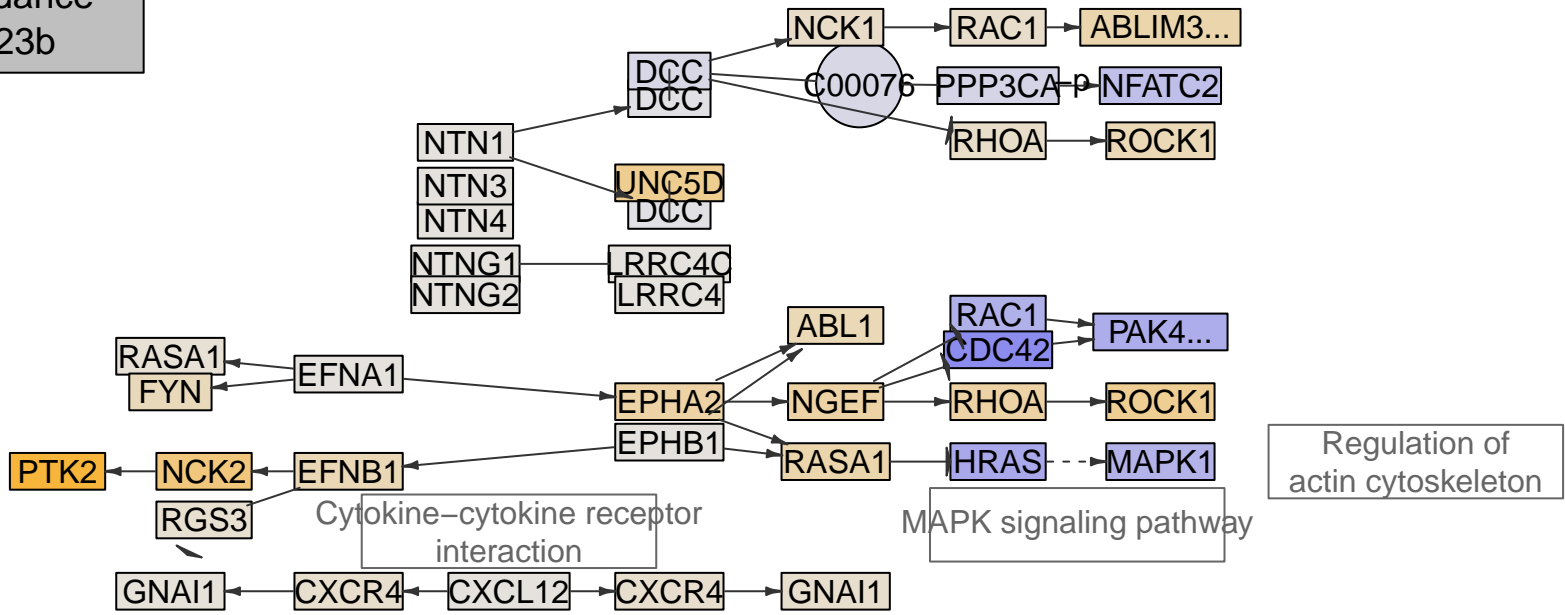

Regulation of actin cytoskeleton

MAPK signaling pathway

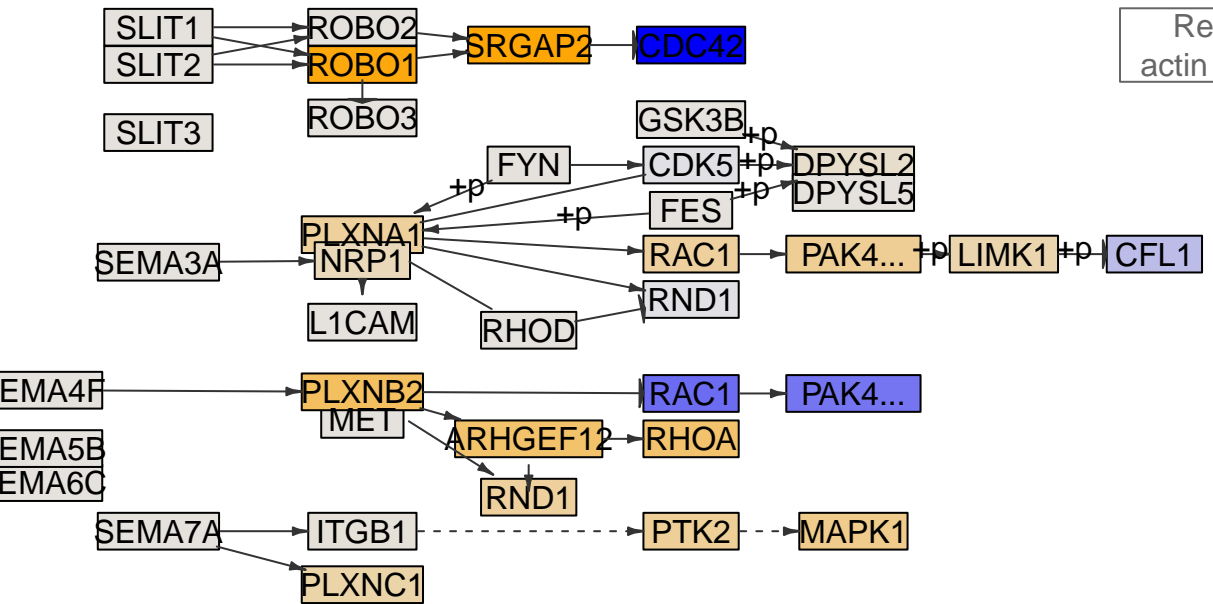

Regulation of actin cytoskeleton

Regulation of actin cytoskeleton