

Cellular senescence

all genes

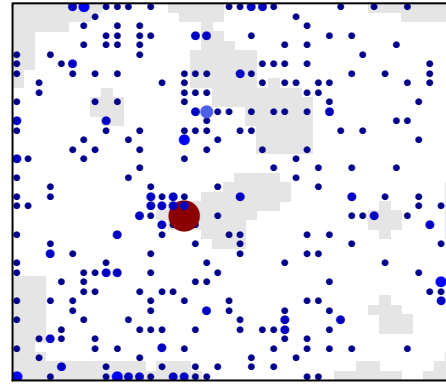

sink node genes

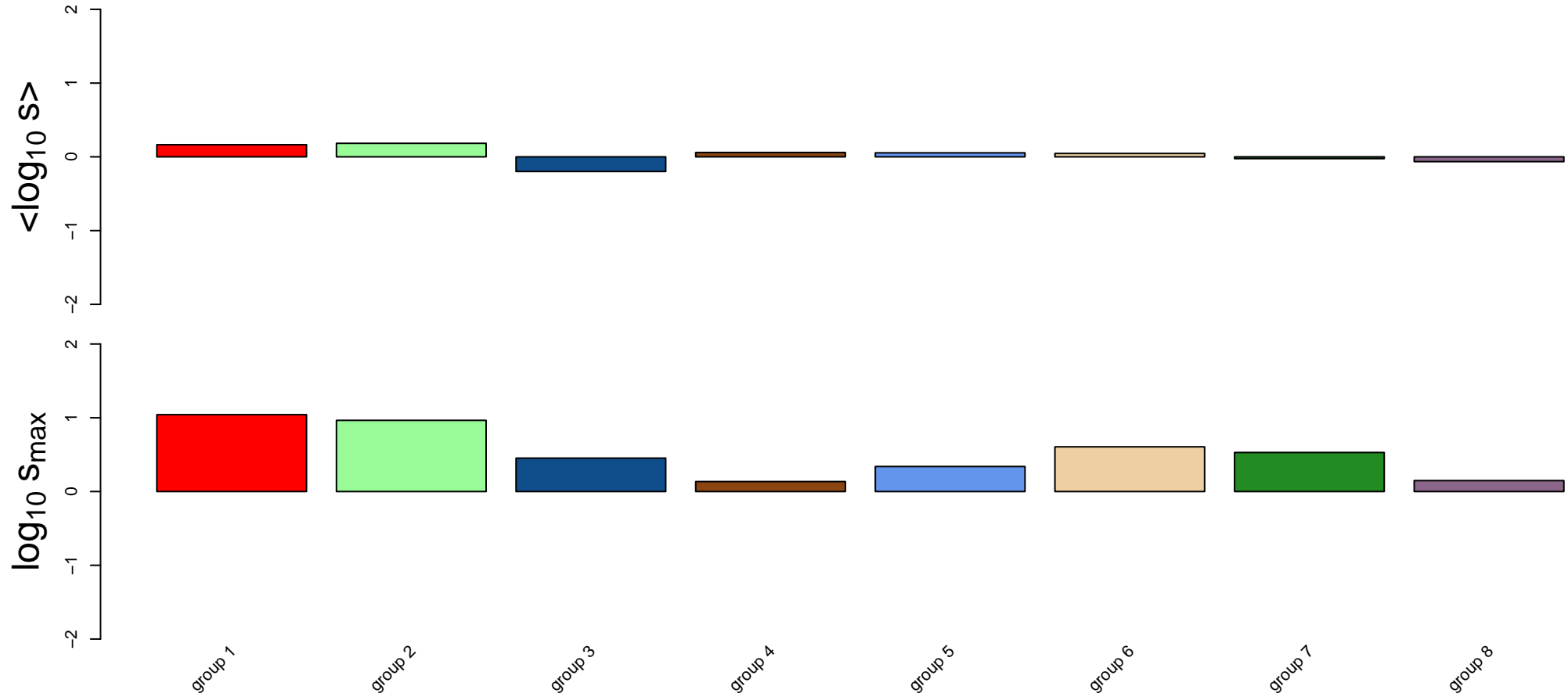
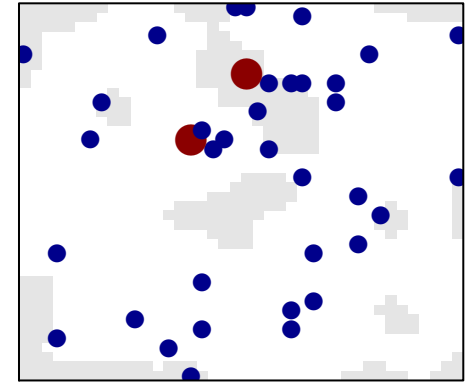

Cellular_senescence genes with data

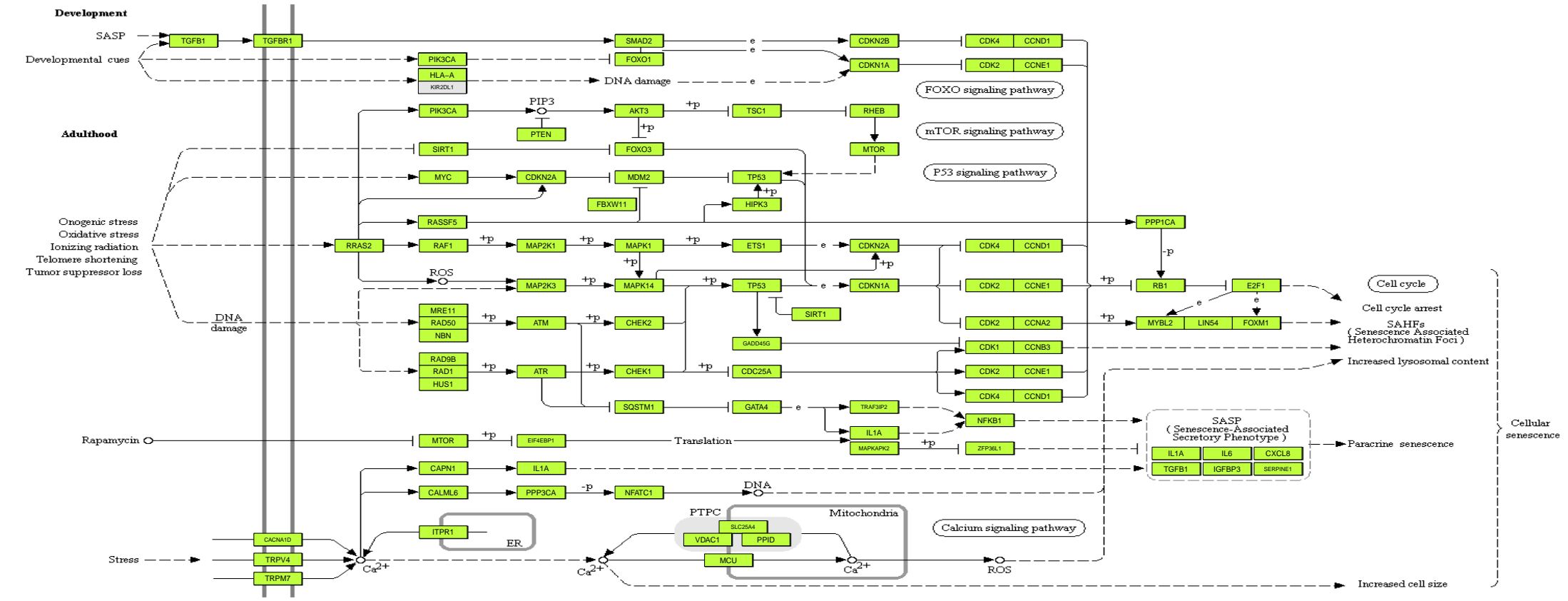

Cellular senescence sink nodes

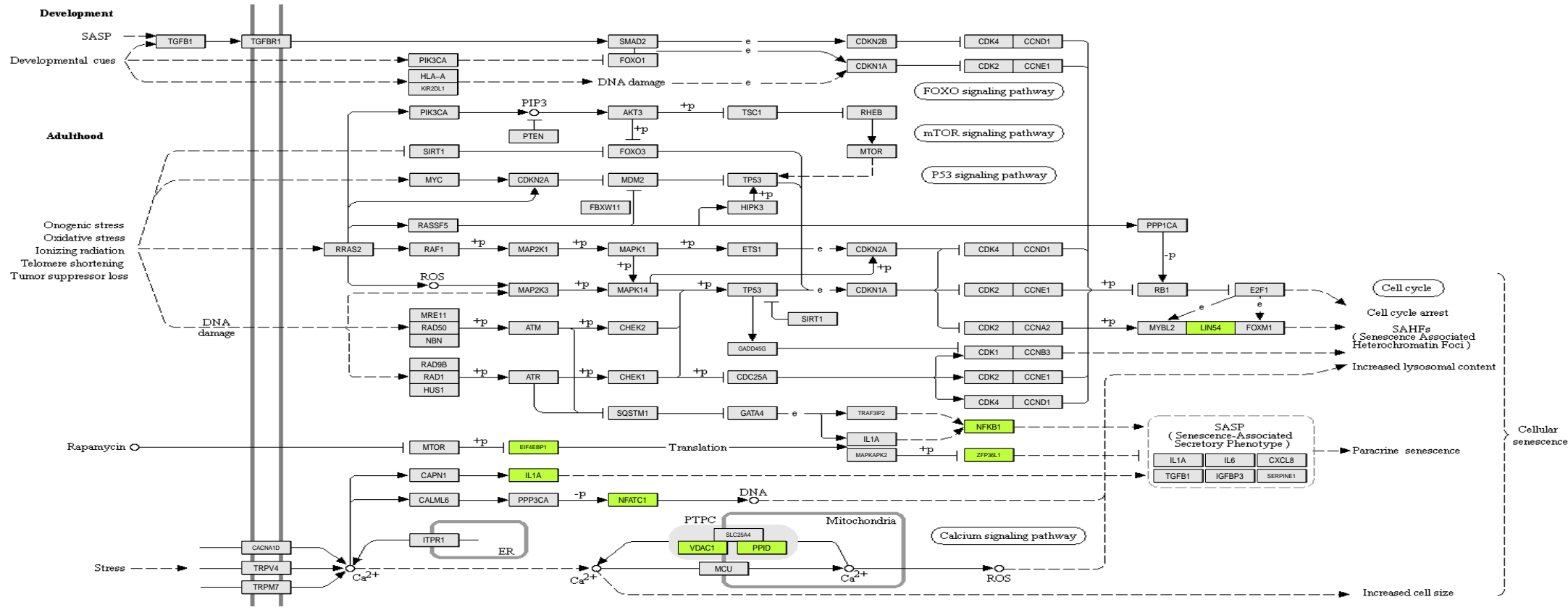

Cellular_senescence_group_1

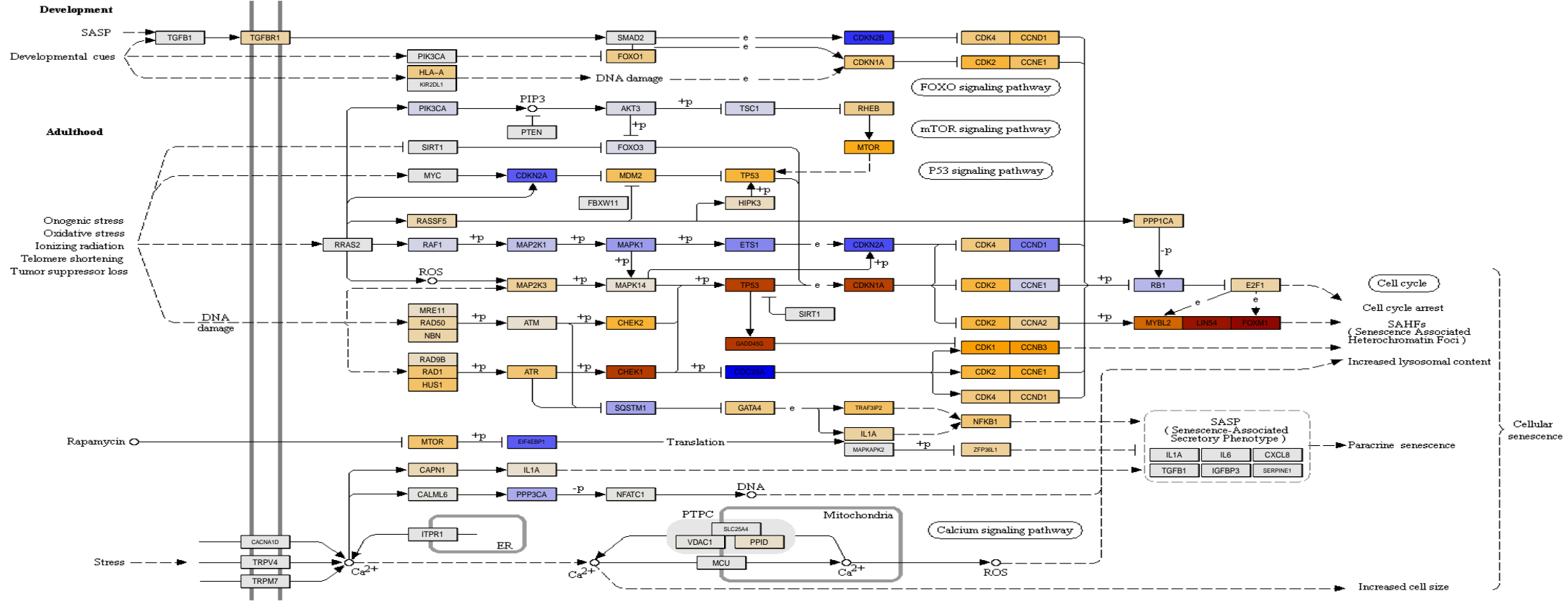

Cellular_senescence_group.2

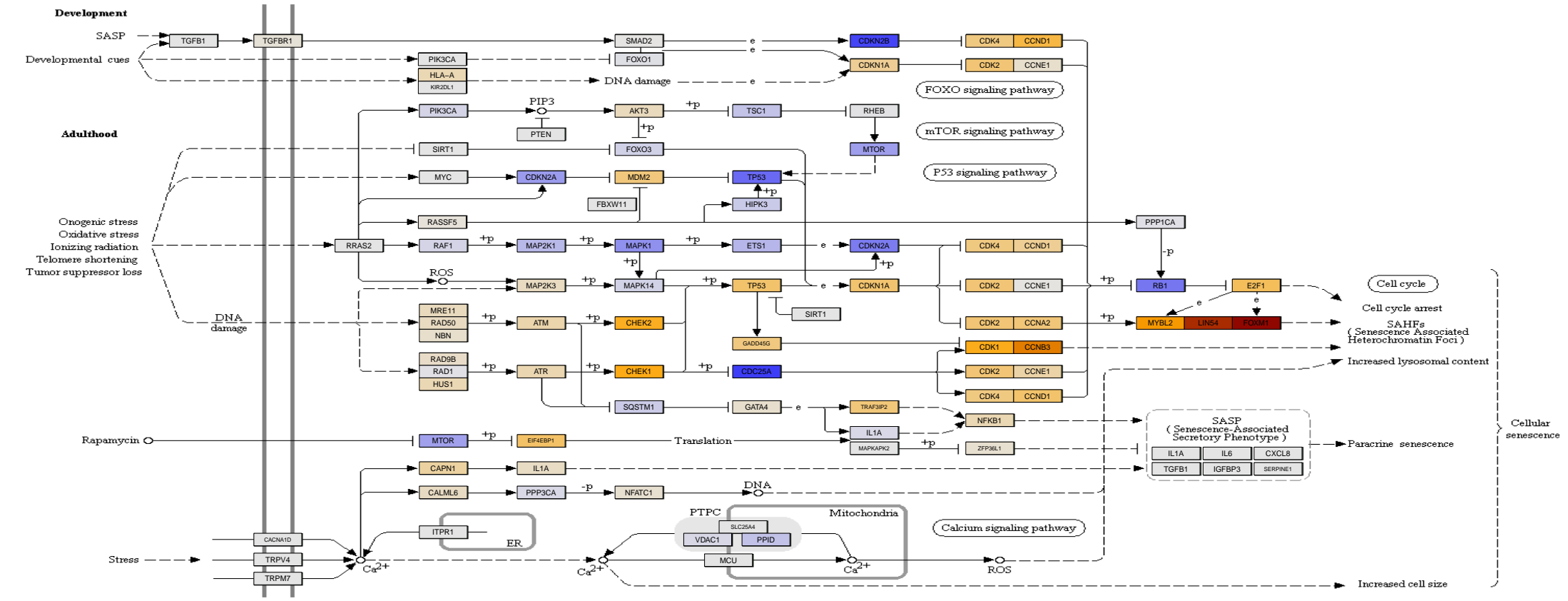

Cellular_senescence_group.3

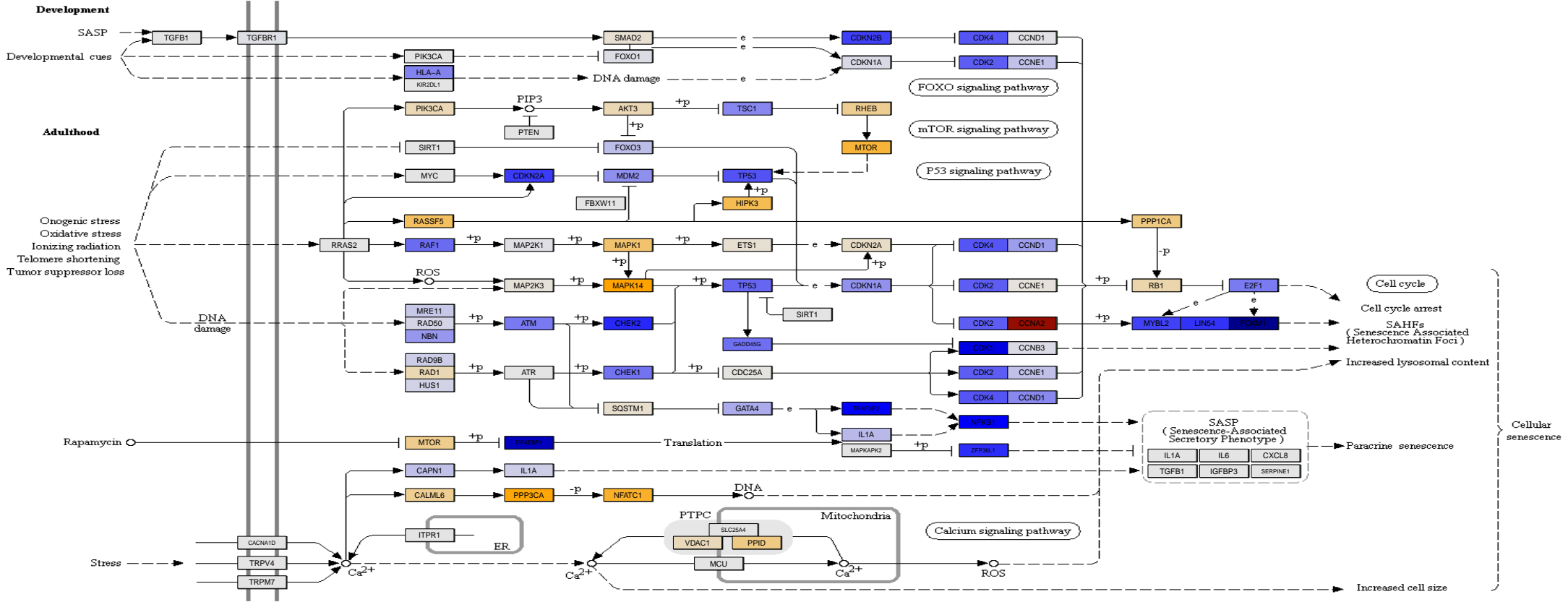

Cellular_senescence_group.4

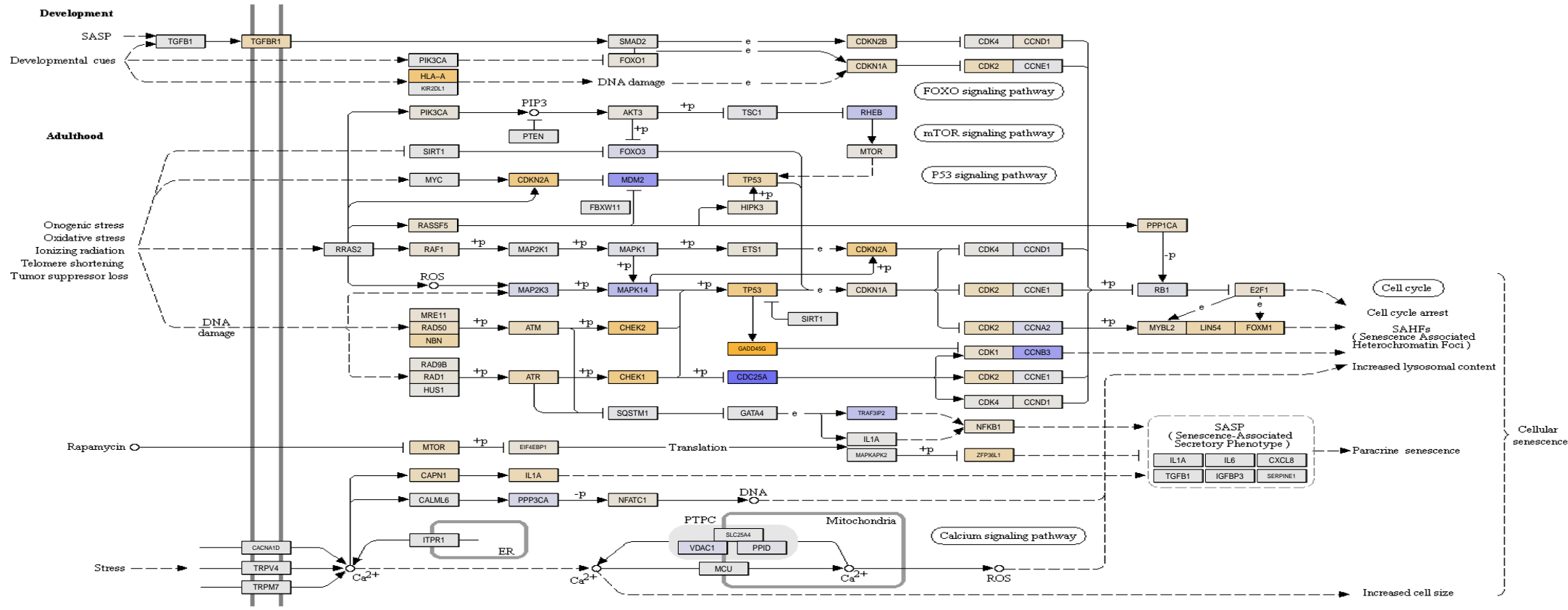

Cellular_senescence_group.5

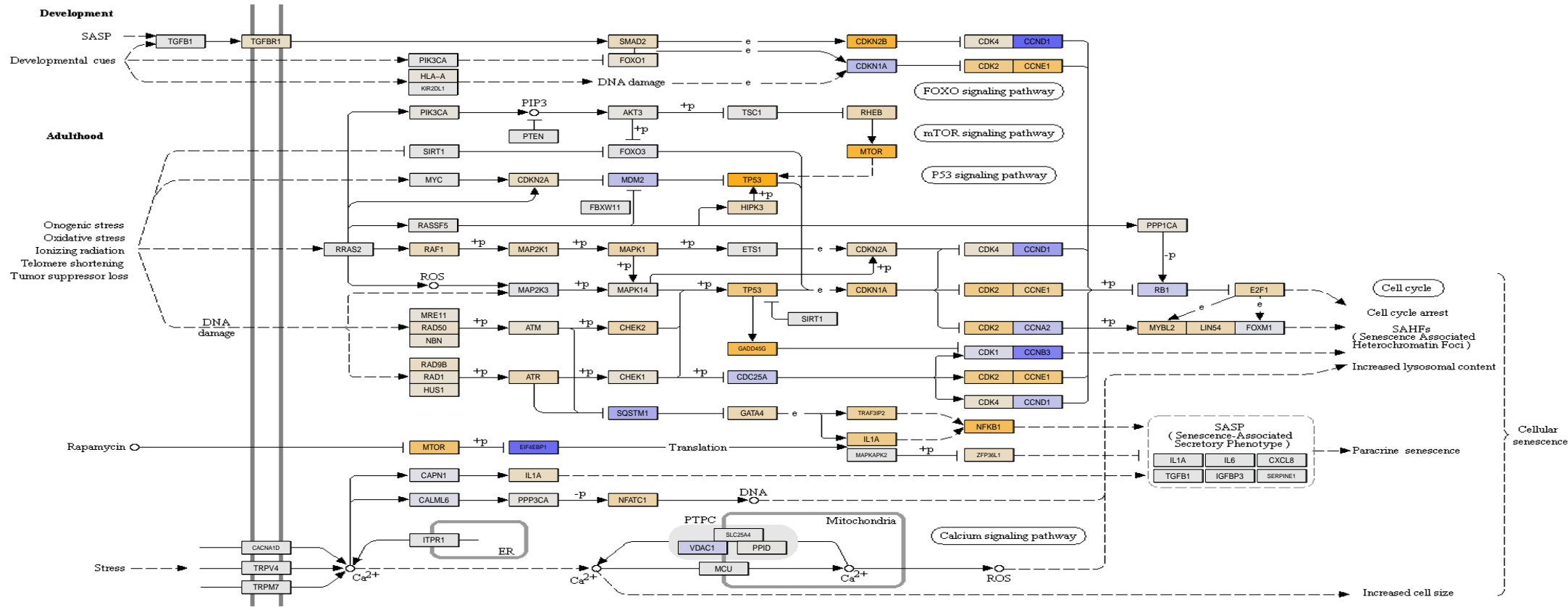

Cellular_senescence_group.6

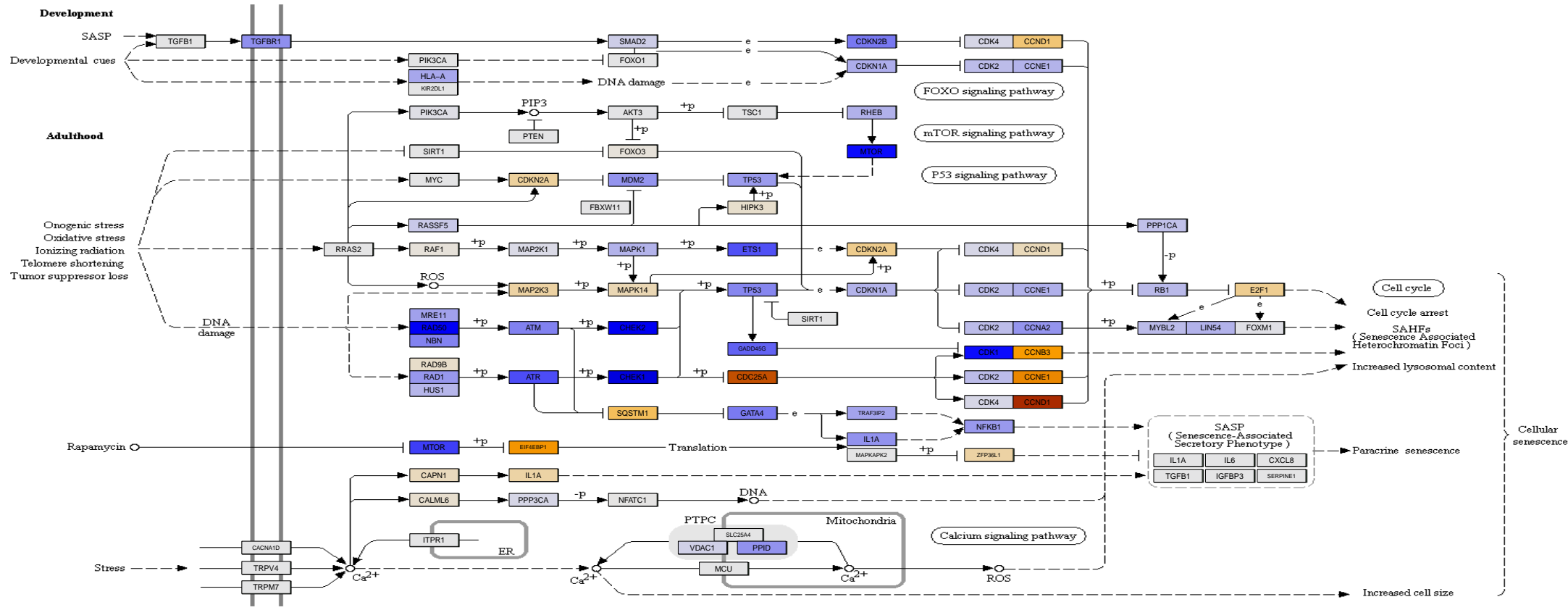

Cellular_senescence_group.7

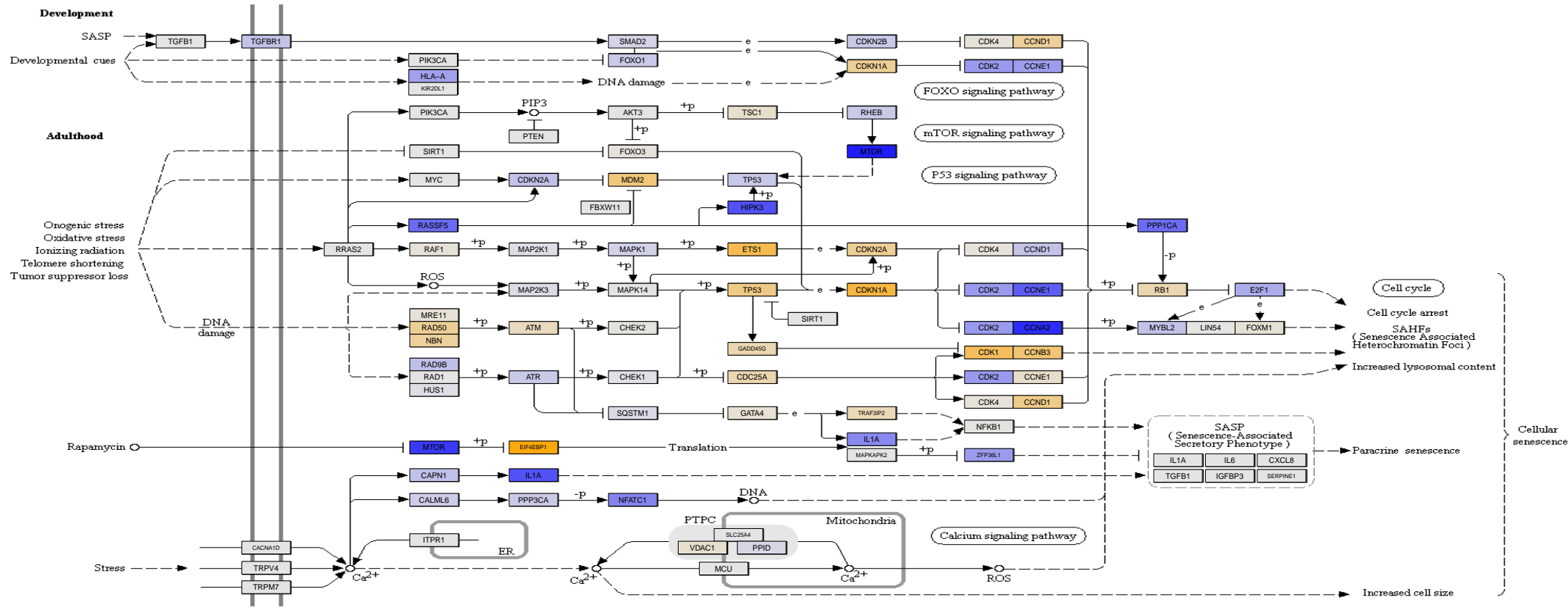

Cellular_senescence_group.8

